

RTS47JP

Hardware Kit Includes Loose:

- (1) 8 – Hex head bolts (M8-1.25 x 20mm) Grade 8
- (2) 12 – Lock washers (M8) Grade 8
- (3) 12 – Flat washers (M8) Grade 8
- (4) 4 – M8 Plastic Push Nuts
- (5) 4 – Hex head nuts (M8-1.25) Grade 8
- (6) 8 – Button head bolts (M6-1.25) Grade 8
- (7) 16 – Flat washers (M6) Grade 8
- (8) 8 – Lock washers (M6) Grade 8
- (9) 8 – Hex head nuts (M6-1.25) Grade 8

Components List:

- (1) 2 – 1 Driver/1 Passenger RT Steps
- (2) 2 – Front Mounting Brackets (RTSPN140)
- (3) 2 – Middle Mounting Brackets (RTSPN141)
- (4) 4 – M8 RT Step T Bolt (RTSPN175)

**LOOSE FIT ALL COMPONENTS.
DO NOT TIGHTEN UNTIL ALL
COMPONENTS ARE INSTALLED
AND ADJUSTED.**

**DISCLAIMER: USE ONLY
COMPONENTS AND HARDWARE
SUPPLIED BY ICI.
NO SUBSTITUTIONS.**

Step by Step Installation Instructions

- STEP 1:** Read and understand instructions completely before beginning installation.
- STEP 2:** (If Equipped) Remove all factory steps or rock sliders and hardware from Jeep.
- STEP 3:** Locate the driver's side step (center of front foot step is 27" to front of bar, notch faces towards front of vehicle. see figure A). Each step uses 2 mounting brackets; front (RTSPN140), and rear (RTSPN141). Locate and identify brackets (see figure B).
- STEP 4:** There are 4 holes in the pinch weld of the Jeep, using the provided 6mm hardware (button head bolts, flat washers, lock washers, and nuts) loose fit the mounting brackets to these holes in their corresponding locations (front and rear). Once the brackets are loosely fit, use the provided 8mm hardware (20mm hex head bolts, flat washers and lock washers) to attach the mounting brackets to the underside floor (see diagram C).
- STEP 5:** Once all 4 brackets are loose fit to the truck, mount the RT Step to the brackets using provided M8 RT Step T-Bolt, 8mm-1.25x20mm hex head bolts, flat washers, lock washers and nuts (See figure D).
- STEP 6:** Once RT Step is loose fit, tighten brackets to pinch weld and inside rocker. Next, adjust bar up/down and front/back (ensure RT Step has 1/8" gap between the bar and the pinch weld to ensure there is no rubbing), then tighten step to brackets. Repeat for passenger side.

2018 Jeep Wrangler JL 2 Door RTS47JP Installation Instructions

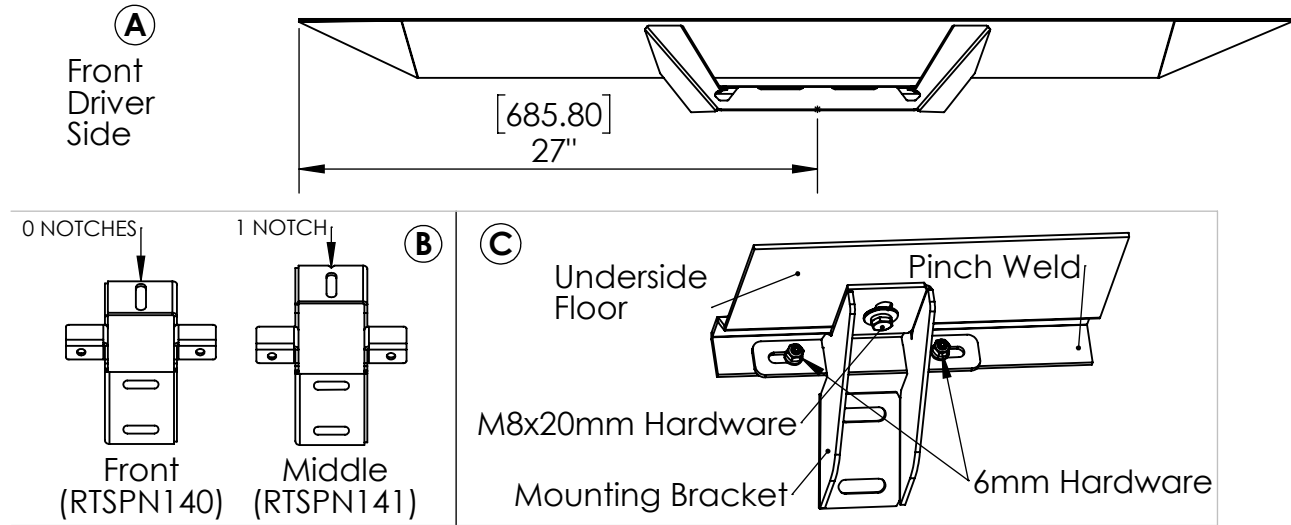

Raptor

