

RTS22FD

MAGNUM RT STEPS

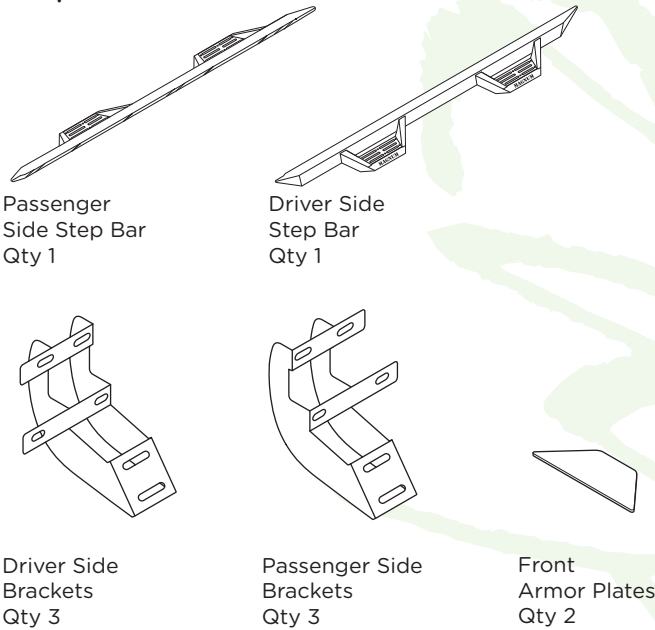

Components:



Hardware:

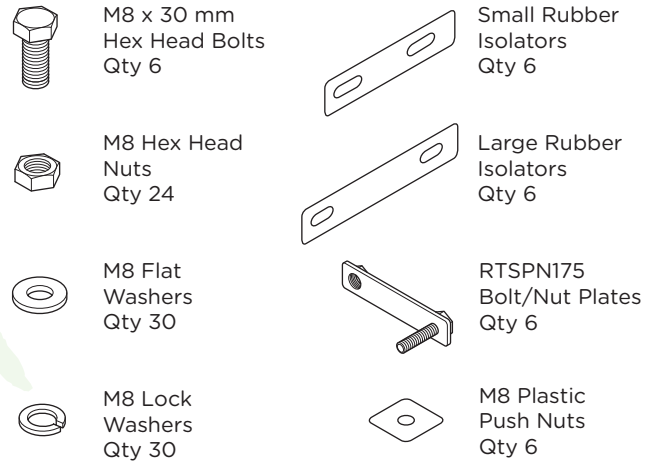

Tools Required:

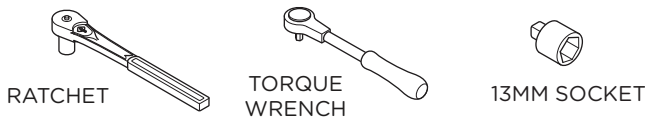

Torque Specifications:

For Rocker Panel Mount Installations
M8 through M12 bolts and nuts are set to 15-20 ft lbs.

Note: When installing the brackets and bars, all hardware must be left loose until all the items are attached.

1. Remove all contents from the package and check steps for any damage. Also, verify that all components and hardware listed above are included before you begin installation.

2. Begin on driver side of vehicle.

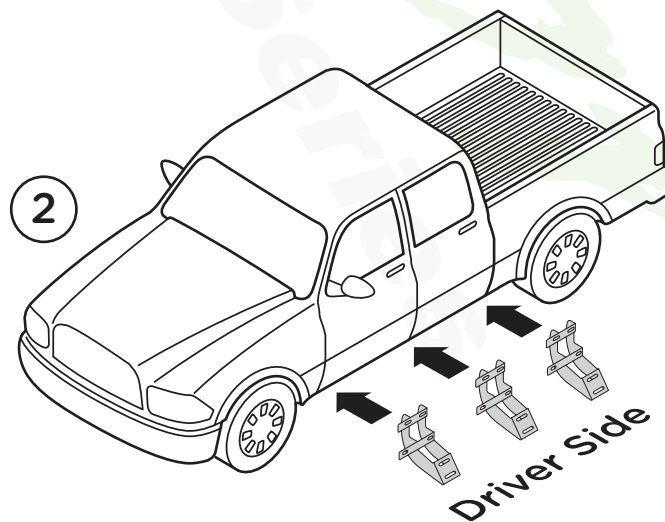

3. Existing mounting studs are located on the interior wall of the rocker panel. These mounting studs will be used for the following instructions.

Mounting studs may be painted and need to be cleaned with an M8-1.25 die before the M8 Hex Head Nut will properly thread. Do not try to force thread the nut on the stud as this could strip the nut.

4. Place Rubber Isolators between the brackets and rocker panel to prevent corrosion caused by aluminum to steel contact. The Small Rubber Isolator is used on the top and the Large Rubber Isolator is used on the bottom of the bracket mounting points.

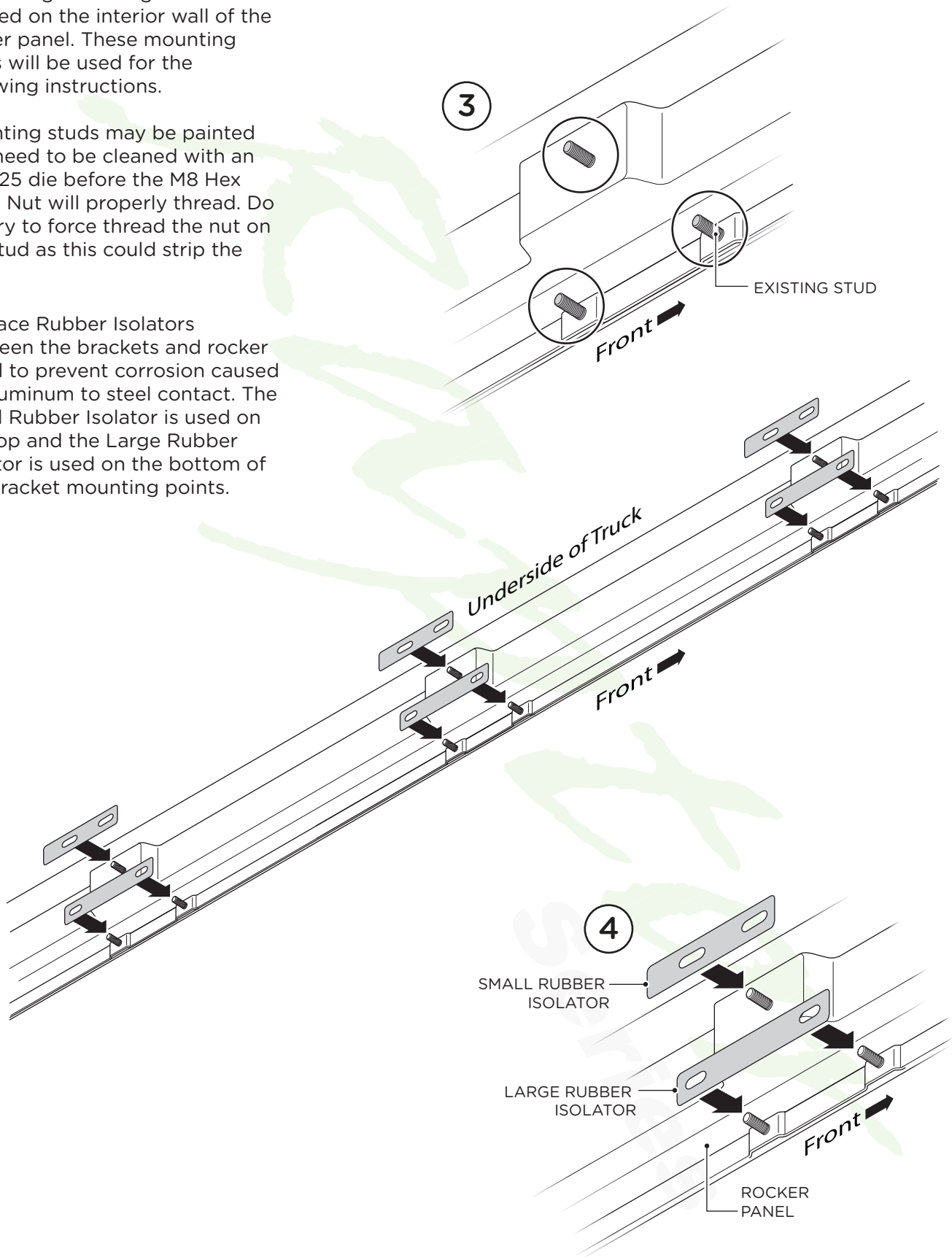

5. On the driver side of the vehicle, align the Front, Center and Rear brackets as shown.

6. Position each bracket onto the existing mounting studs on the rocker panel. Fasten by using three (3) M8 Flat Washers, three (3) M8 Lock Washers and three (3) M8 Hex Head Nuts per bracket.

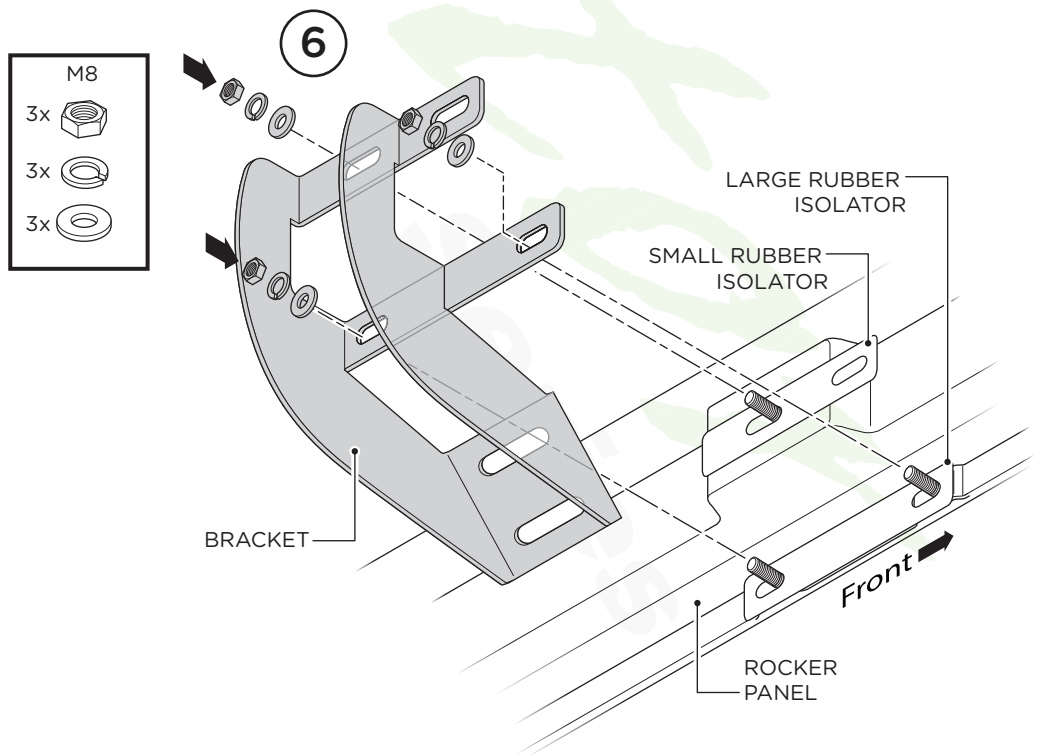
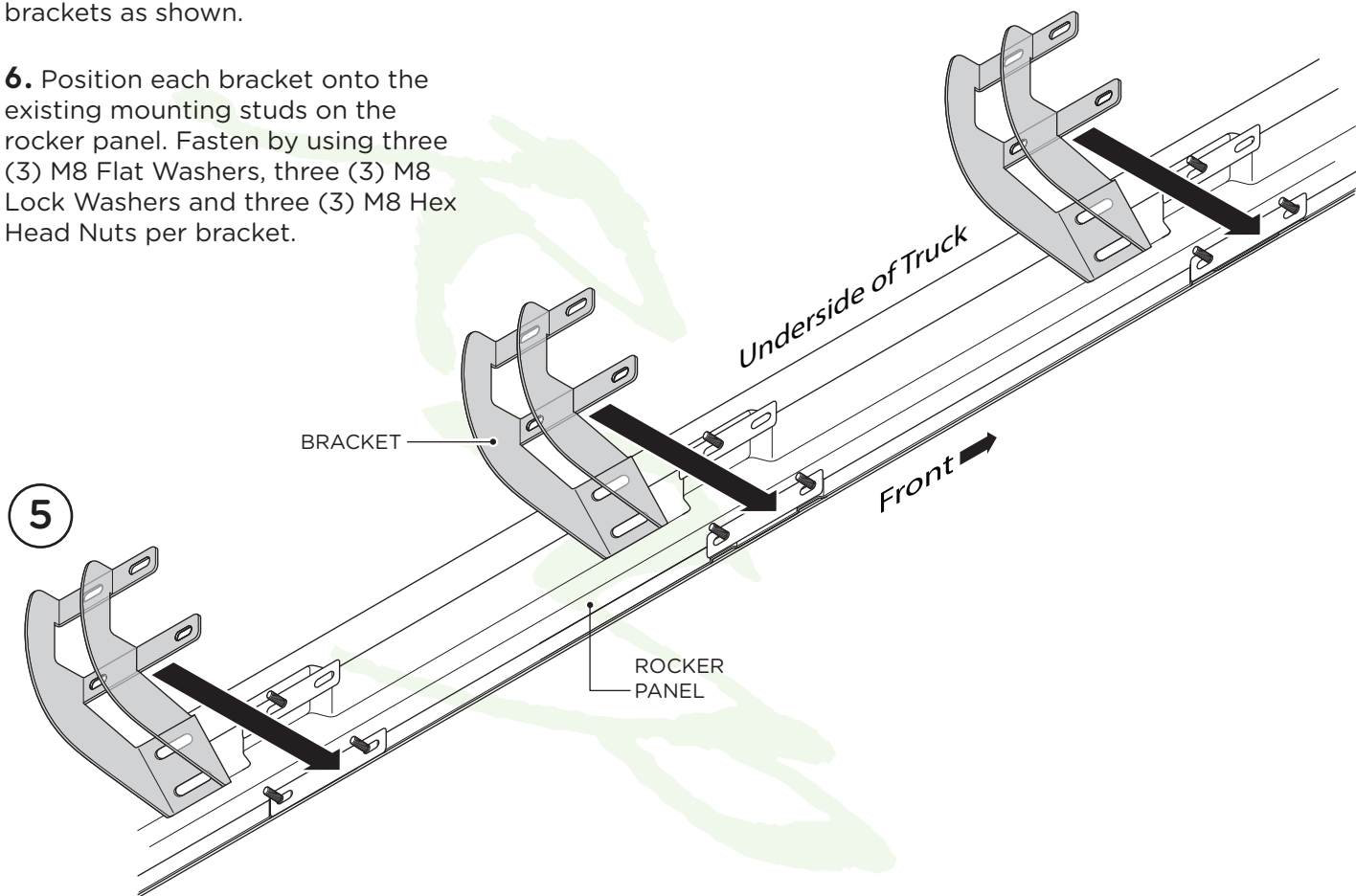

Installing the Step Bar

7. Line up mounting points on the step bar with the mounting holes in each bracket.

8. Fasten the step bar to each bracket using one (1) RTSPN175 Bolt/Nut Plate, one (1) Plastic Push Nut, one (1) M8 Hex Head Nut, two (2) M8 Lock Washers, two (2) M8 Flat Washers and one (1) M8 x 30MM Hex Head Bolt.

9. Adjust the bars front/back and up/down to desired placement. Once you have the step positioned, tighten until the split lock washer is flat between the bolt head and flat washer. Do not over tighten.

10. When all hardware is in place, everything must be tightened. See page 1 for torque specifications. Repeat these steps for opposite side installation.

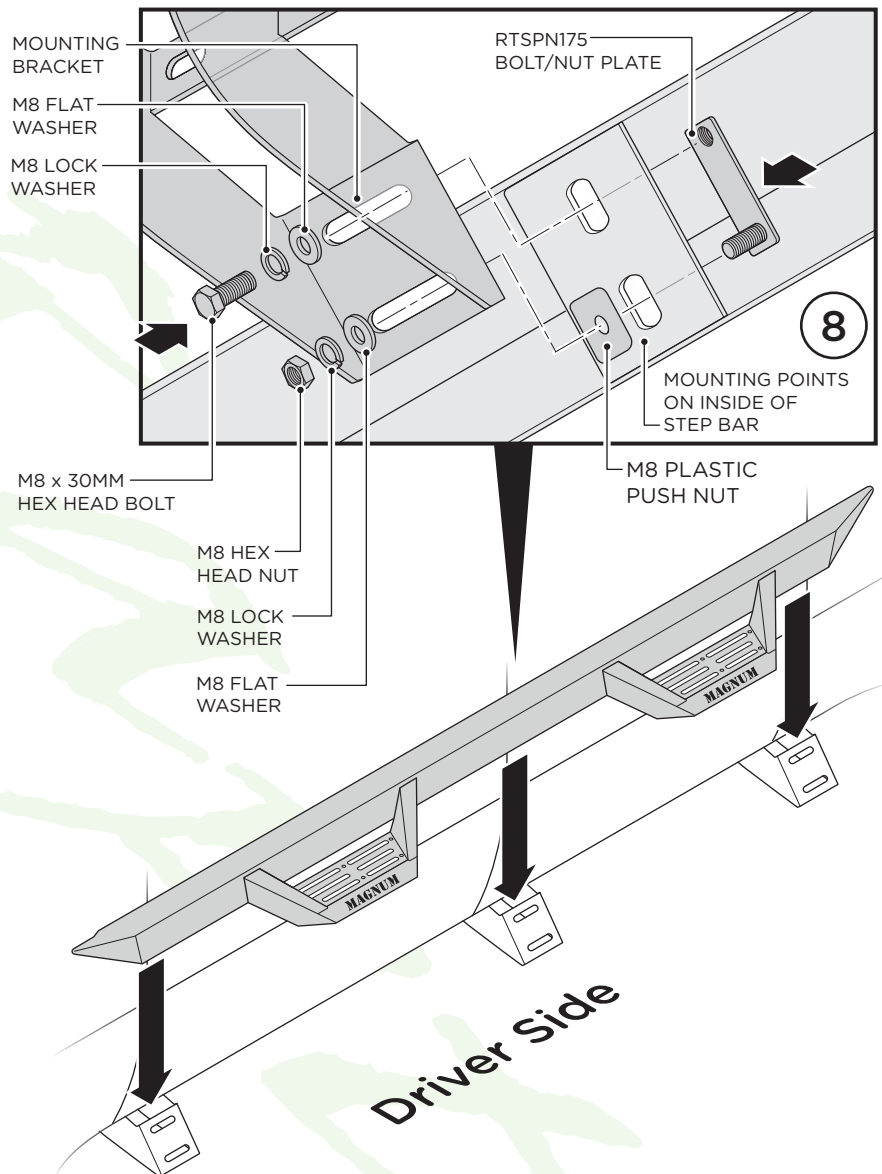

OPTIONAL:

If you wish to install the Front Armor Plates, begin by thoroughly cleaning the front side of the front step where the Front Armor Plate will attach.

1. Remove adhesive protection from the Front Armor Plate.

2. Carefully line up with the front side of the front step. Be careful not to let the side overhang as they could peel off over time.

Once lined up, firmly press the Front Armor Plate on the step to ensure complete adhesion.

Repeat these steps for opposite side.

