

BRACKET KIT INSTALLATION

SKU# RB-0103-BK



COMPONENTS		HARDWARE	
<p>DRIVER SIDE</p> <p>Qty: 1 Front Bracket</p> <p>Qty: 1 Center Bracket</p> <p>Qty: 1 Rear Bracket</p>	<p>PASSENGER SIDE</p> <p>Qty: 1 Front Bracket</p> <p>Qty: 1 Center Bracket</p> <p>Qty: 1 Rear Bracket</p> <p>Qty: 2 Diesel Front/Center Upper Bracket</p> <p>Qty: 2 Diesel Front/Center Lower Bracket</p>	<p>Qty: 14 M8 x 30MM Hex Head Bolts</p> <p>Qty: 38 M8 Flat Washers</p> <p>Qty: 26 M8 Lock Washers</p> <p>Qty: 8 U-Nut Clip</p> <p>Qty: 2 M10 Lock Washers</p> <p>Qty: 18 M8 Hex Head Nut</p> <p>Qty: 8 Nylon Washer</p> <p>Qty: 2 M10 x 30MM Hex Head Bolts</p> <p>Qty: 2 M10 Flat Washers</p>	
TOOLS REQUIRED		INSTALLATION NOTES	
<p>RATCHET</p> <p>TORQUE WRENCH</p> <p>13MM SOCKET</p> <p>17MM SOCKET</p> <p>RETAINER REMOVAL TOOL</p> <p>13MM RATCHET WRENCH</p>	<p>NOTE: Center Bracket is NOT used on Regular Cab Models</p> <p>TORQUE NOTE: Bolts and nuts should be torqued to 15-20 ft lbs.</p> <p>NOTE: Hardware for Board Installation is included.</p> <p>NOTE: Some spare hardware is included.</p>		

Remove all contents from the package and check brackets for any damage. Also, verify that all components and hardware listed above are included before you begin installation.

Read through entire installation manual and installation drawings to ensure that you understand all of the components and hardware before proceeding with installation.

NOTE: When installing the brackets, all hardware must be left loose until all of the items are attached.

Locate factory hole locations in (3) places per side on the body mount.

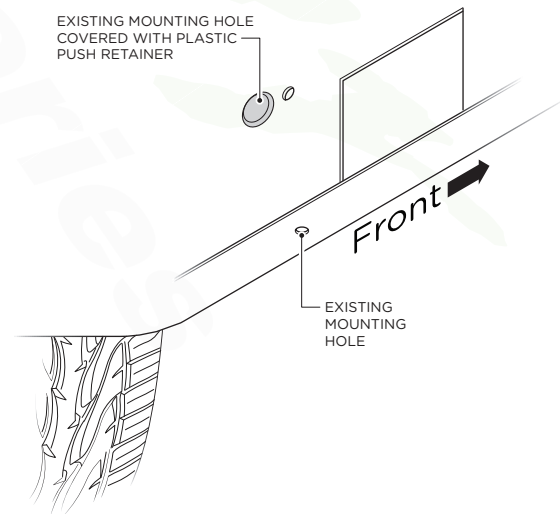
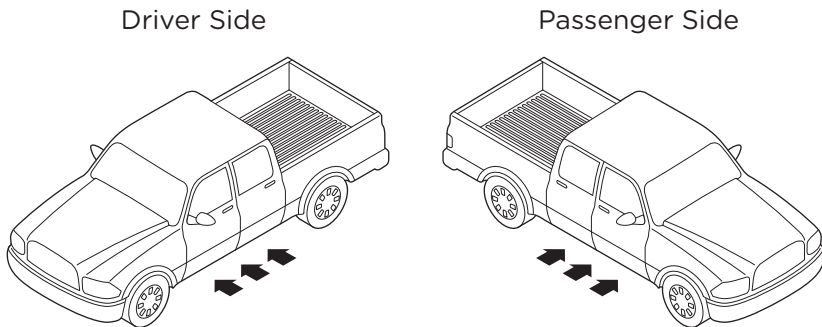

BRACKET ORIENTATION

DRIVER SIDE

Raptor
Series

NOTE: Center Bracket is NOT Used on Regular Cab Models

1. Begin installation on driver side. Position the Front Bracket, Center Bracket and Rear Bracket as shown in diagram.

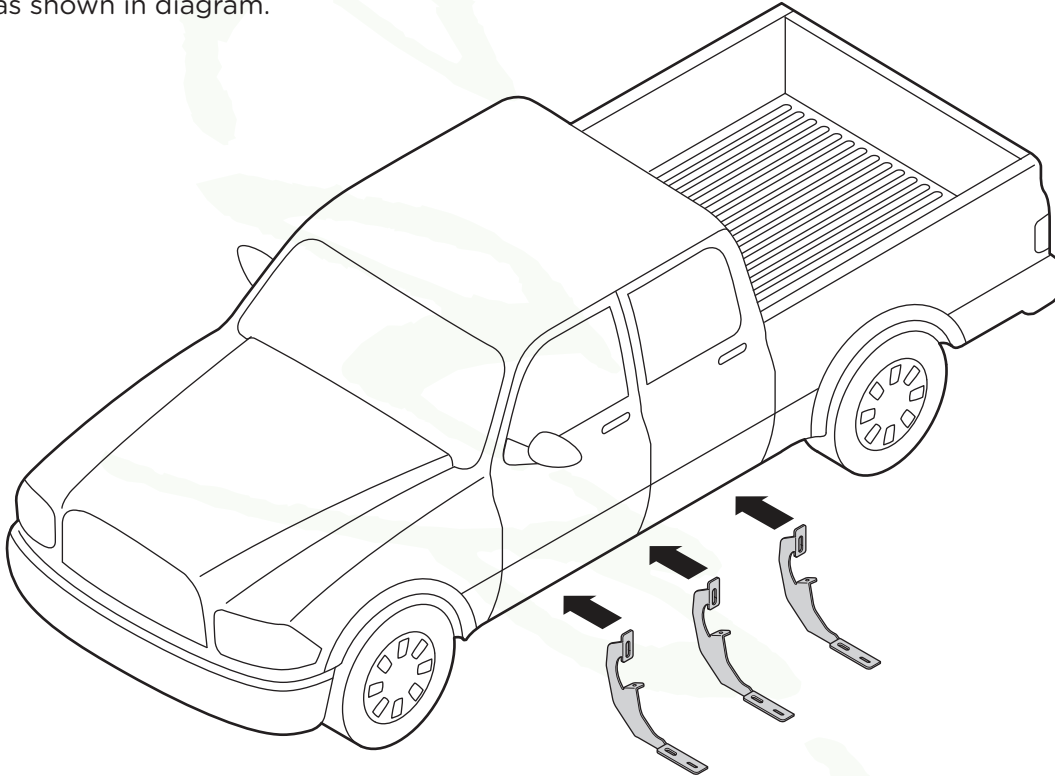

2. Driver Side Front, Center and Rear Bracket cradles (2a, 2b and 2c) will face towards the front of the truck.

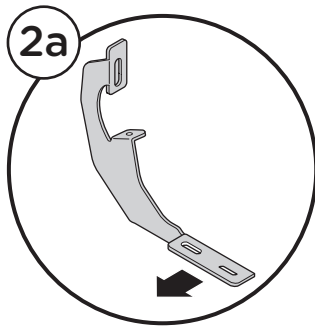

Driver Side
Front Bracket

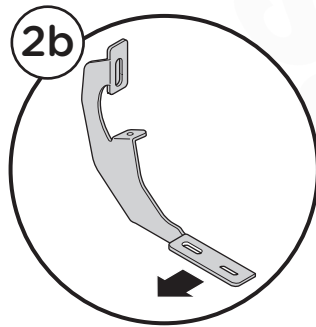

Driver Side
Center Bracket

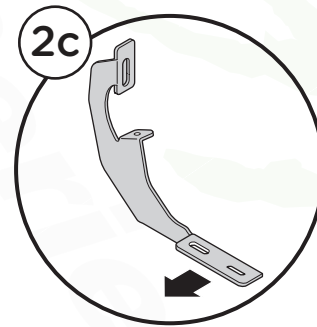

Driver Side
Rear Bracket

PLASTIC PUSH RETAINER REMOVAL

DRIVER SIDE

Raptor
Series

NOTE: Removal of Plastic Push Retainer is needed to expose factory holes.

3. Follow the steps shown below to show removal of the Plastic Push Retainer and installation of M8 U-Nut.

Use Retainer Removal Tool to grab underneath the Plastic Push Retainer in the rocker panel.

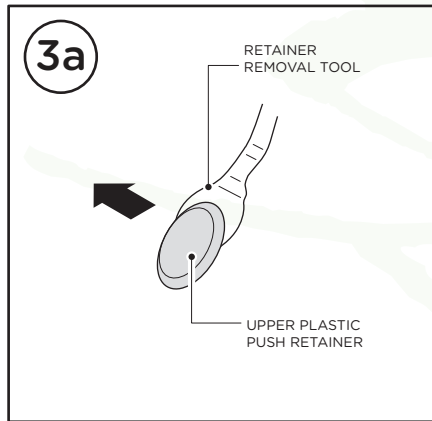

Pull the Plastic Push Retainer out of the rocker panel to expose threaded holes that will be used for bracket installation.

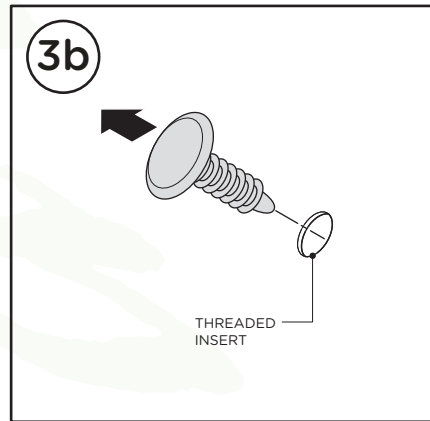

Insert each M8 U-Nut Clip into existing holes in rocker panel, making sure the treads are on the inside of the rocker panel.

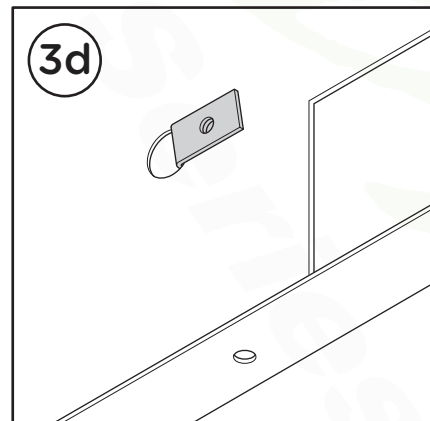
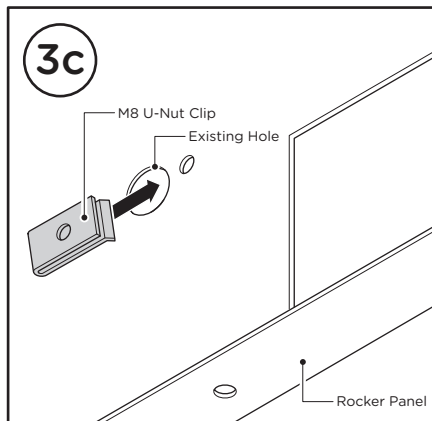

BRACKETS & RUNNING BOARD INSTALLATION

DRIVER SIDE

Raptor
Series

- 4.** Fasten the top portion of the Driver Side Front, Center and Rear Bracket by using (1) M8 x 30MM Hex Head Bolt, (1) M8 Flat Washer and (1) M8 Lock Washer.

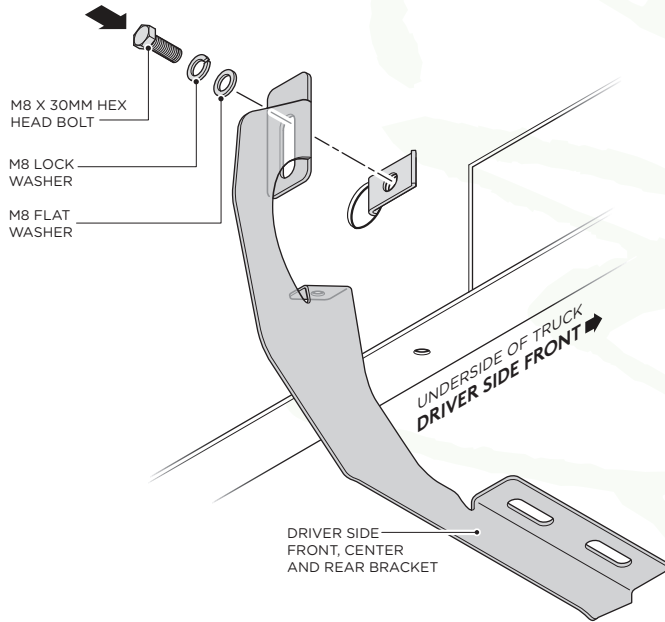

- 5.** Fasten the bottom portion of the Driver Side Front, Center and Rear Bracket by using (1) M8 x 30MM Hex Head Bolt, (1) M8 Flat Washer and (1) M8 Lock Washer.

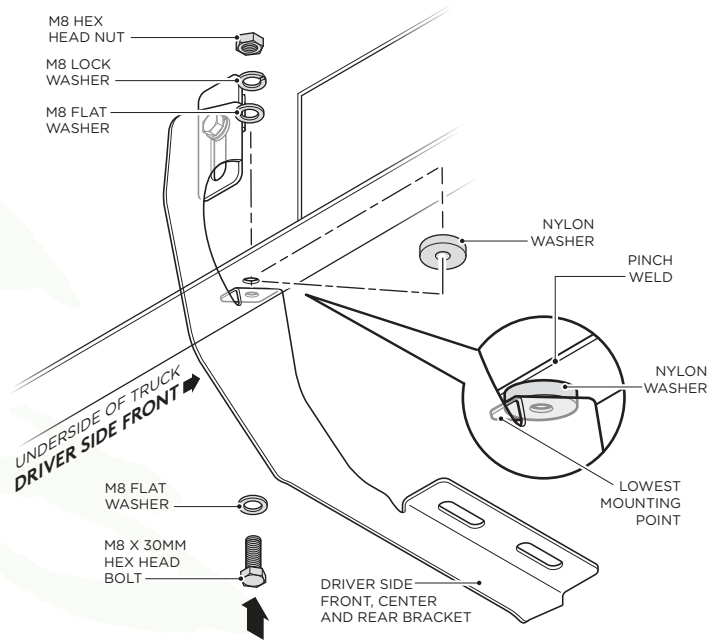

- 6.** Fasten the Running Board to the Driver Side Front, Center and Rear Bracket cradles by using (2) M8 Flat Washers, (2) M8 Lock Washers and (2) M8 Hex Head Nuts.

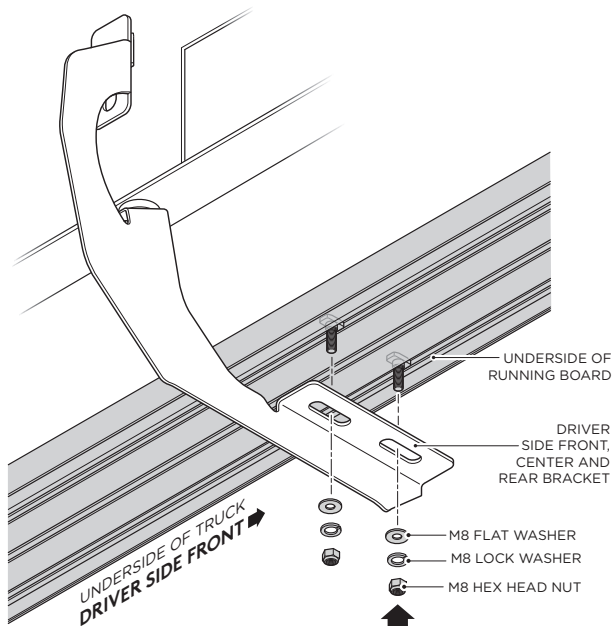

BRACKET ORIENTATION

PASSENGER SIDE

Raptor
Series

NOTE: If installing on a gas vehicle, proceed with step 1.

NOTE: If installing on a diesel vehicle, skip to step 6.

NOTE: Center Bracket is NOT Used on Regular Cab Models

1. Begin installation on passenger side. Position the Front Bracket, Center Bracket and Rear Bracket as shown in diagram.

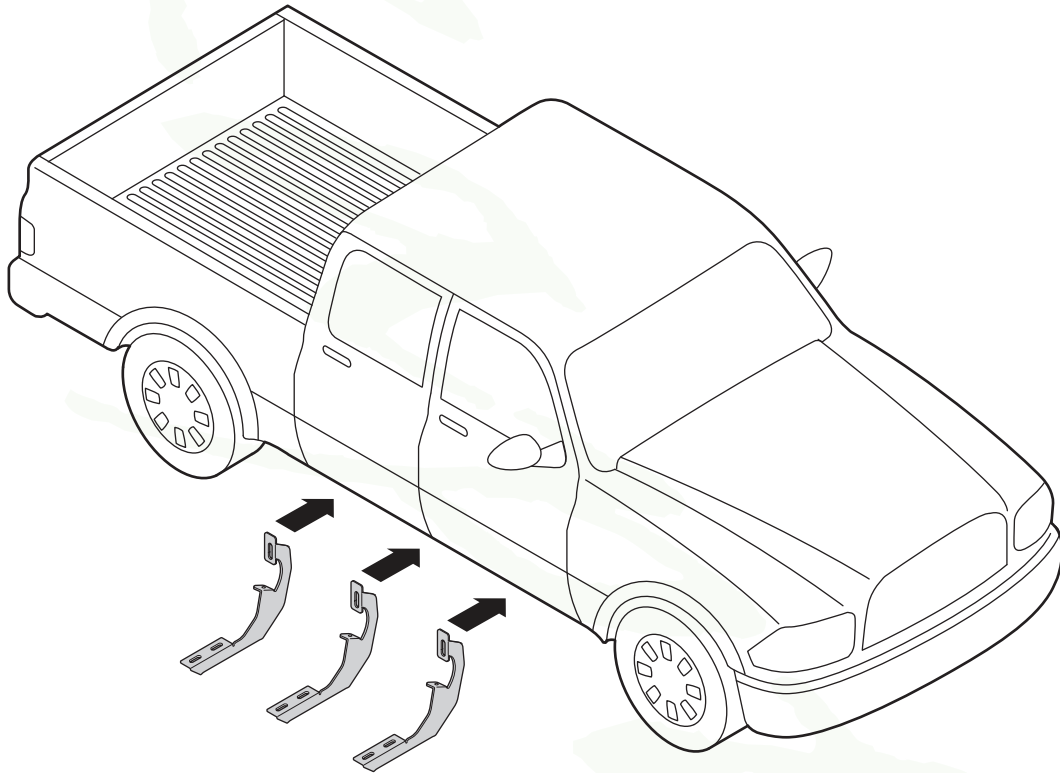

2. Passenger Side Front, Center and Rear Bracket cradles (2a, 2b and 2c) will face towards the rear of the truck.

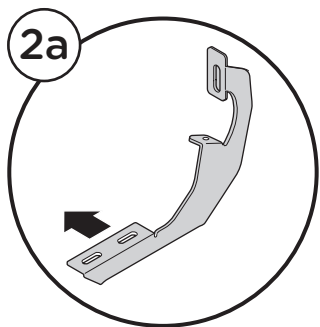

Passenger Side
Front Bracket

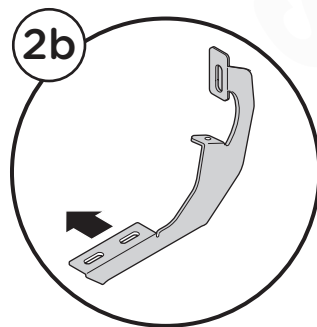

Passenger Side
Center Bracket

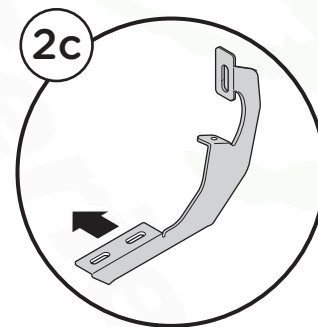

Passenger Side
Rear Bracket

PLASTIC PUSH RETAINER REMOVAL

PASSENGER SIDE

Raptor
Series

NOTE: Removal of Plastic Push Retainer is needed to expose factory holes.

3. Follow the steps shown below to show removal of the Plastic Push Retainer and installation of M8 U-Nut.

Use Retainer Removal Tool to grab underneath the Plastic Push Retainer in the rocker panel.

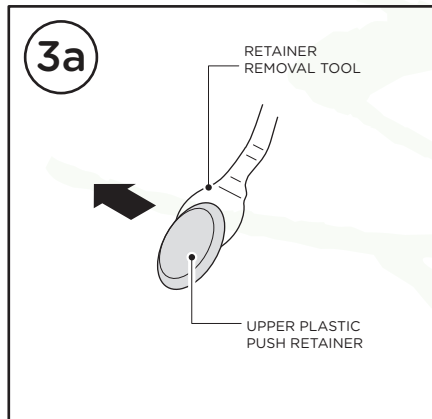

Pull the Plastic Push Retainer out of the rocker panel to expose threaded holes that will be used for bracket installation.

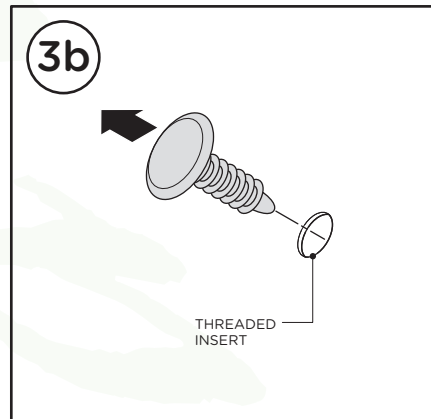

Insert each M8 U-Nut Clip into existing holes in rocker panel, making sure the treads are on the inside of the rocker panel.

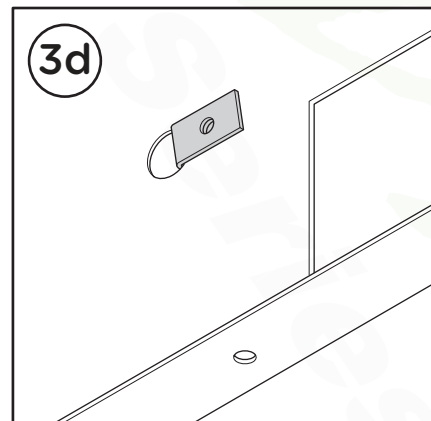
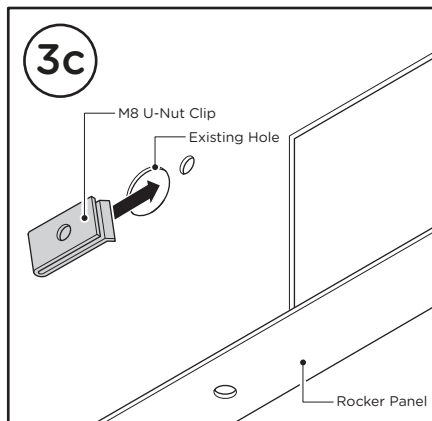

BRACKETS & RUNNING BOARD INSTALLATION

PASSENGER SIDE

Raptor
Series

4. Fasten the top portion of the Passenger Side Front, Center and Rear Bracket by using (1) M8 x 30MM Hex Head Bolt, (1) M8 Flat Washer and (1) M8 Lock Washer.

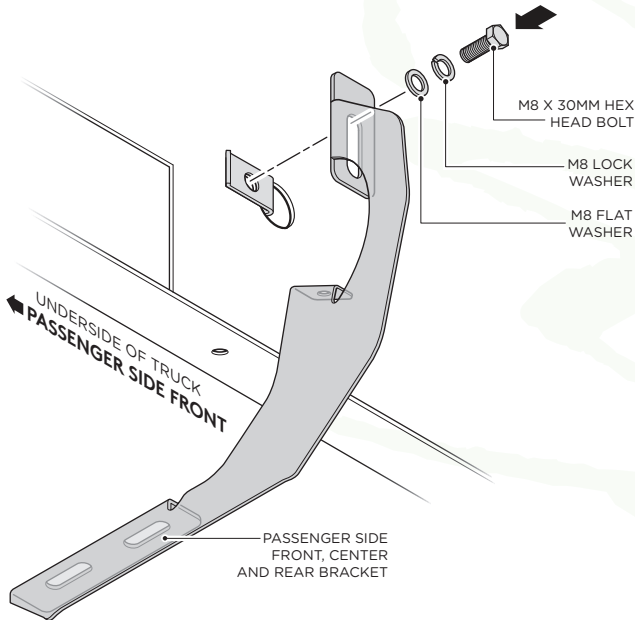

5. Fasten the bottom portion of the Passenger Side Front, Center and Rear Bracket by using (1) M8 x 30MM Hex Head Bolt, (1) M8 Flat Washer and (1) M8 Lock Washer.

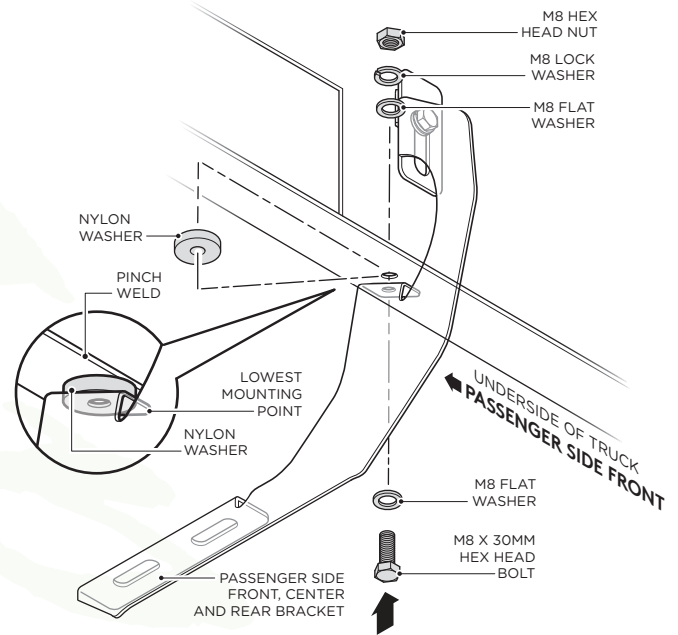

6. Fasten the Running Board to the Passenger Side Front, Center and Rear Bracket cradles by using (2) M8 Flat Washers, (2) M8 Lock Washers and (2) M8 Hex Head Nuts.

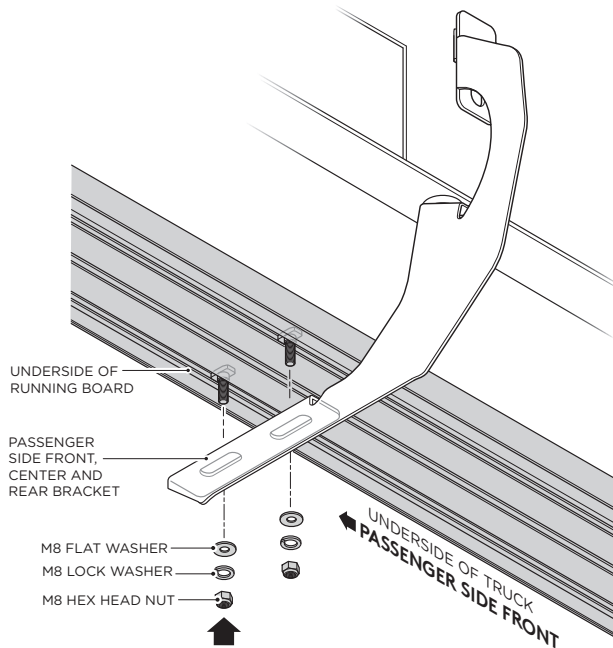

BRACKET ORIENTATION ON DIESEL MODEL WITH DEF TANK PASSENGER SIDE



NOTE: If installing on a diesel model with DEF tank, you must use Diesel Front/Center Upper/Lower Brackets on the passenger front and center mounting location.
NOTE: Center Bracket is NOT Used on Regular Cab Models

6. Begin installation on passenger side. Position the Front/Center Upper Brackets and the Front/Center Lower Brackets and the Rear Bracket as shown in diagram.

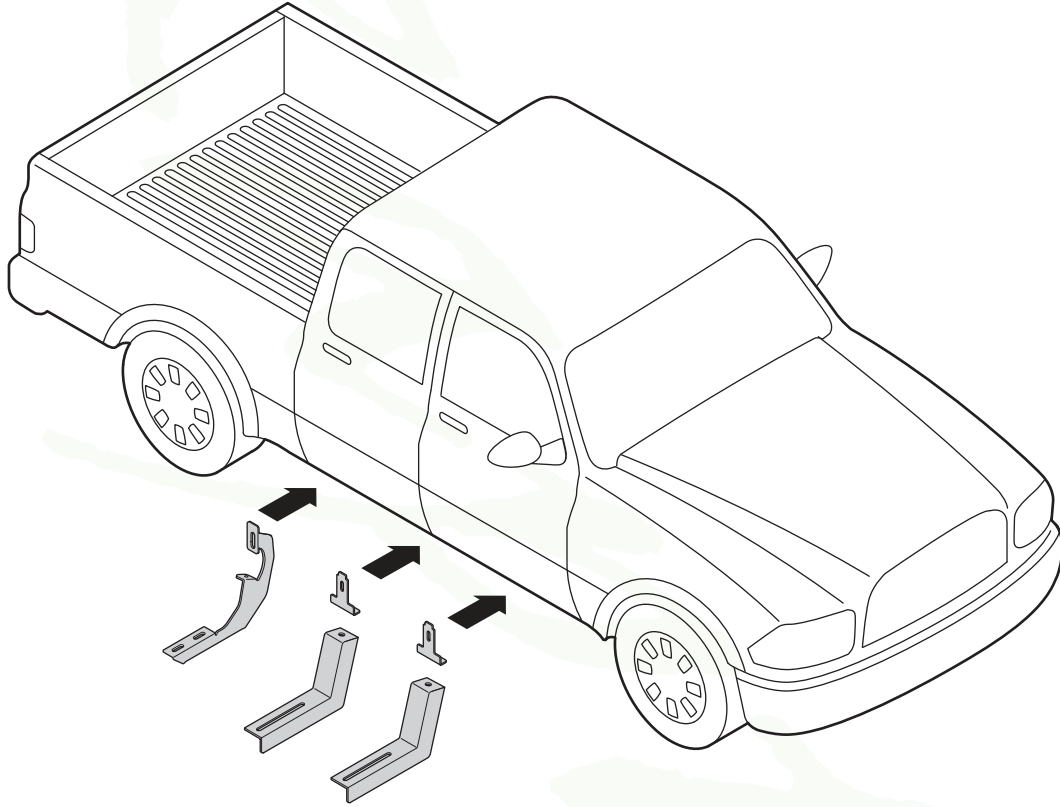

7. Passenger Front/Center Lower Bracket cradles (7a and 7b) and Passenger Rear Bracket cradles (7c) will face towards the rear of the truck.

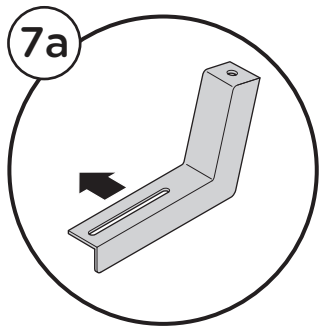

Passenger Side
Front Lower Bracket

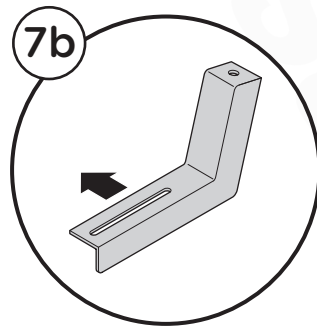

Passenger Side
Center Lower Bracket

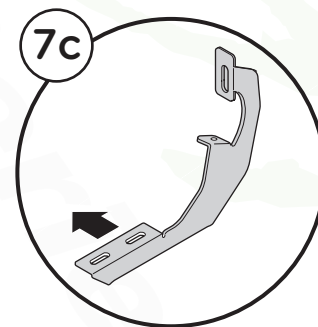

Passenger Side
Rear Bracket

BRACKETS & RUNNING BOARD INSTALLATION ON DIESEL MODEL WITH DEF TANK PASSENGER SIDE



- 8.** Slide Diesel Front/Center Upper Bracket between the DEF tank and the rocker panel (8a). The nut on this bracket will line up with the hole on the pinch weld and the vertical mounting point will be aligned with the threaded hole in the rocker panel (8b). If no threaded hole exists, please install M8 U-Nut Clip.

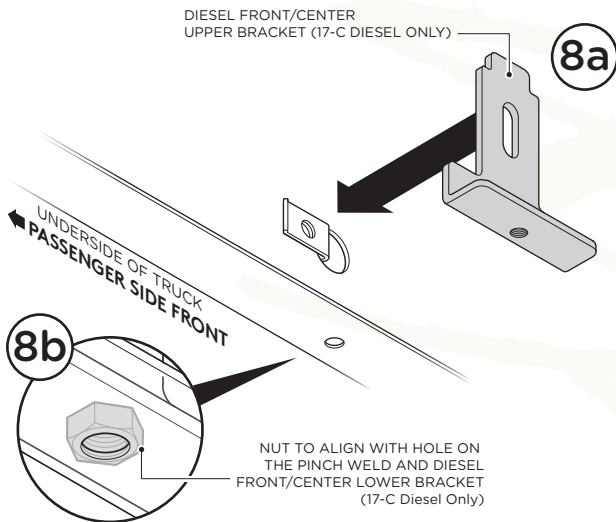

- 9.** Fasten using (1) M8x 30MM Hex Head Bolt, (1) M8 Lock Washer and (1) M8 Flat Washer.

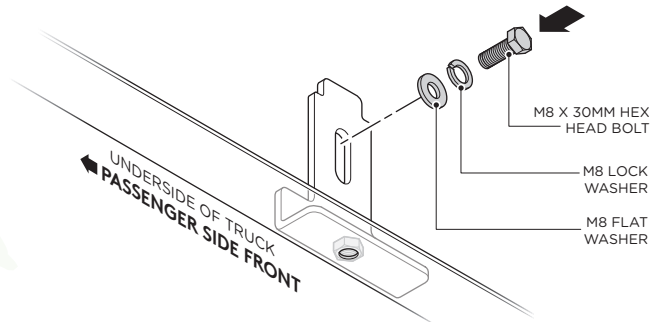

- 10.** Next, hold the Diesel Front/Center Lower Bracket to the bottom of the pinch weld and attach to Diesel Front/Center Upper Bracket using (1) M10x 30MM Hex Head Bolt, (1) M10 Lock Washer (1) M10 Flat Washer.

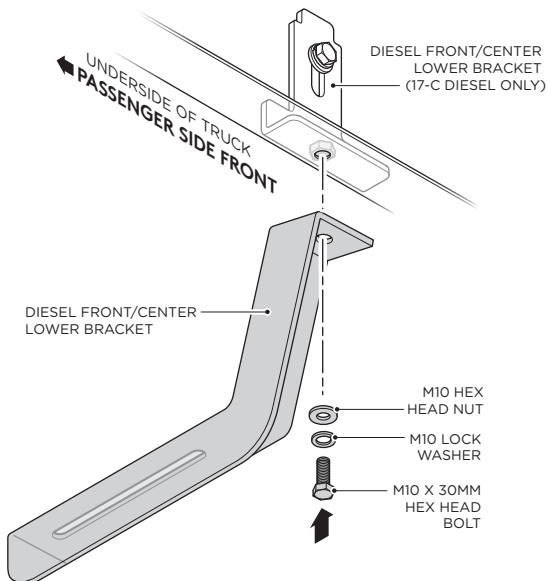

- 11.** Fasten the top portion of the Passenger Side Rear Bracket by using (1) M8 x 30MM Hex Head Bolt, (1) M8 Flat Washer and (1) M8 Lock Washer.

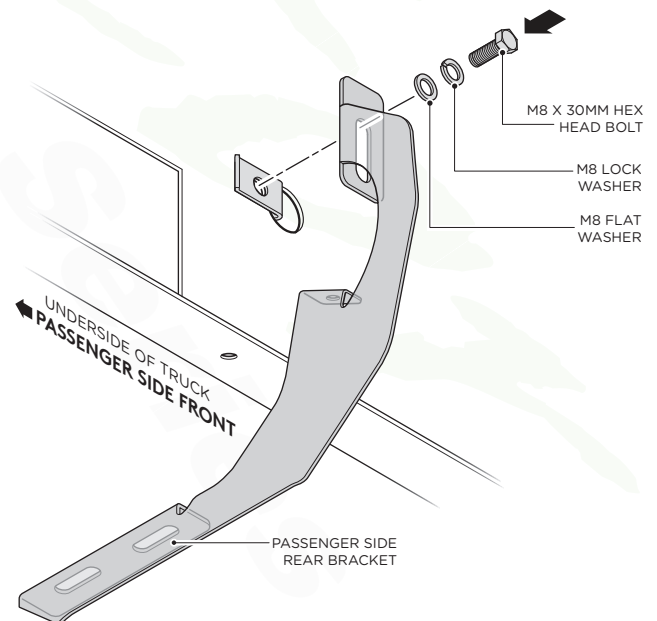

BRACKETS & RUNNING BOARD INSTALLATION ON DIESEL MODEL WITH DEF TANK PASSENGER SIDE



12. Fasten the bottom portion of the Passenger Side Front, Center and Rear Bracket by using (1) M8 x 30MM Hex Head Bolt, (1) M8 Flat Washer and (1) M8 Lock Washer.

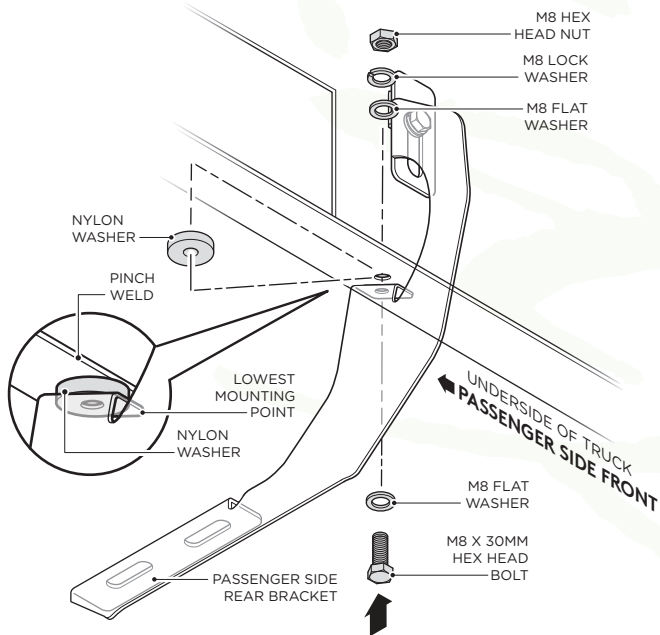

13. Fasten the Running Board to the Passenger Side Front/Center Lower Bracket cradles by using (2) M8 Flat Washers, (2) M8 Lock Washers and (2) M8 Hex Head Nuts.

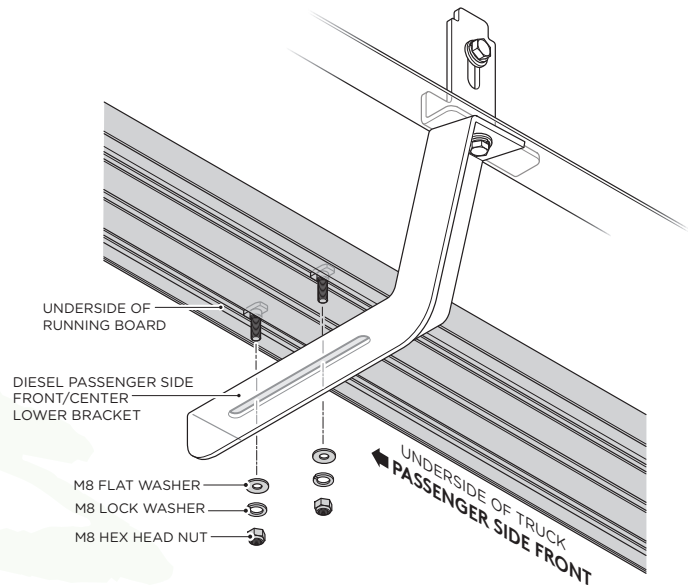

14. Fasten the Running Board to the Passenger Side Rear Bracket cradles by using (2) M8 Flat Washers, (2) M8 Lock Washers and (2) M8 Hex Head Nuts.

