

RB-0200-BK

BRACKET KIT

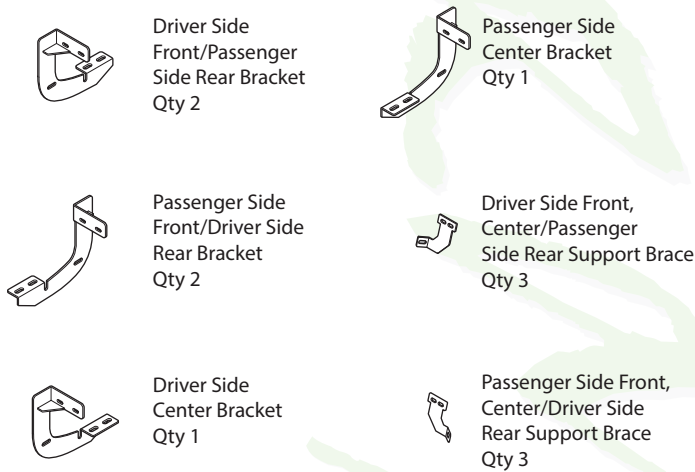

Components:



Hardware:

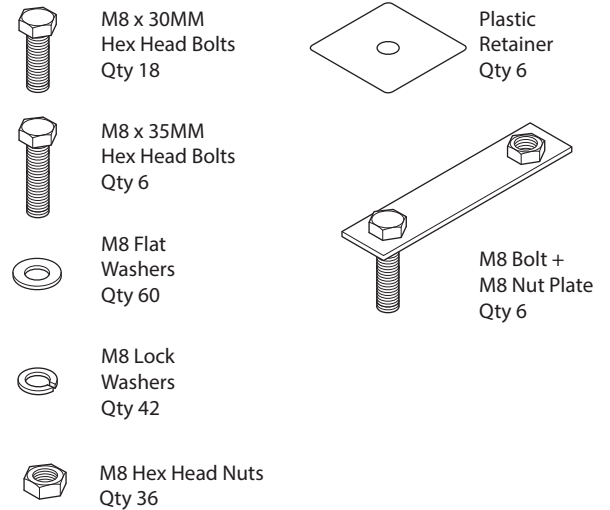

Tools Required:

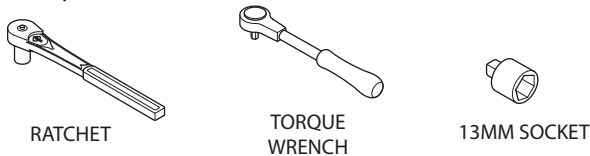

Torque Specifications:

For Rocker Panel Mount Installations
M8 through M12 bolts and nuts are set to 15-20 ft lbs.

Note: When installing the brackets and boards, all hardware must be left loose until all the items are attached.

1. Remove all contents from the package and check running boards for any damage. Also, verify that all components and hardware listed above are included before you begin installation.

2. Locate factory holes in six (6) places under-neath body mount.

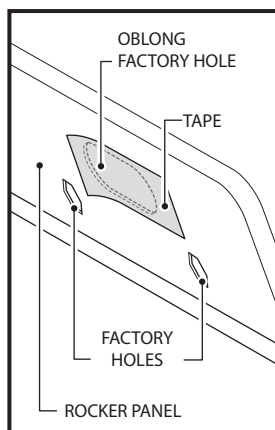

Passenger Side

Driver Side

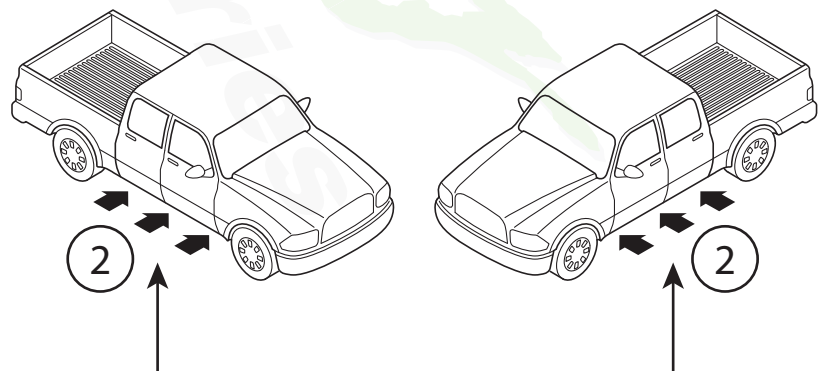

3. Begin installation on passenger side. Position Front Bracket, Center Bracket and Rear Bracket as shown along passenger side.

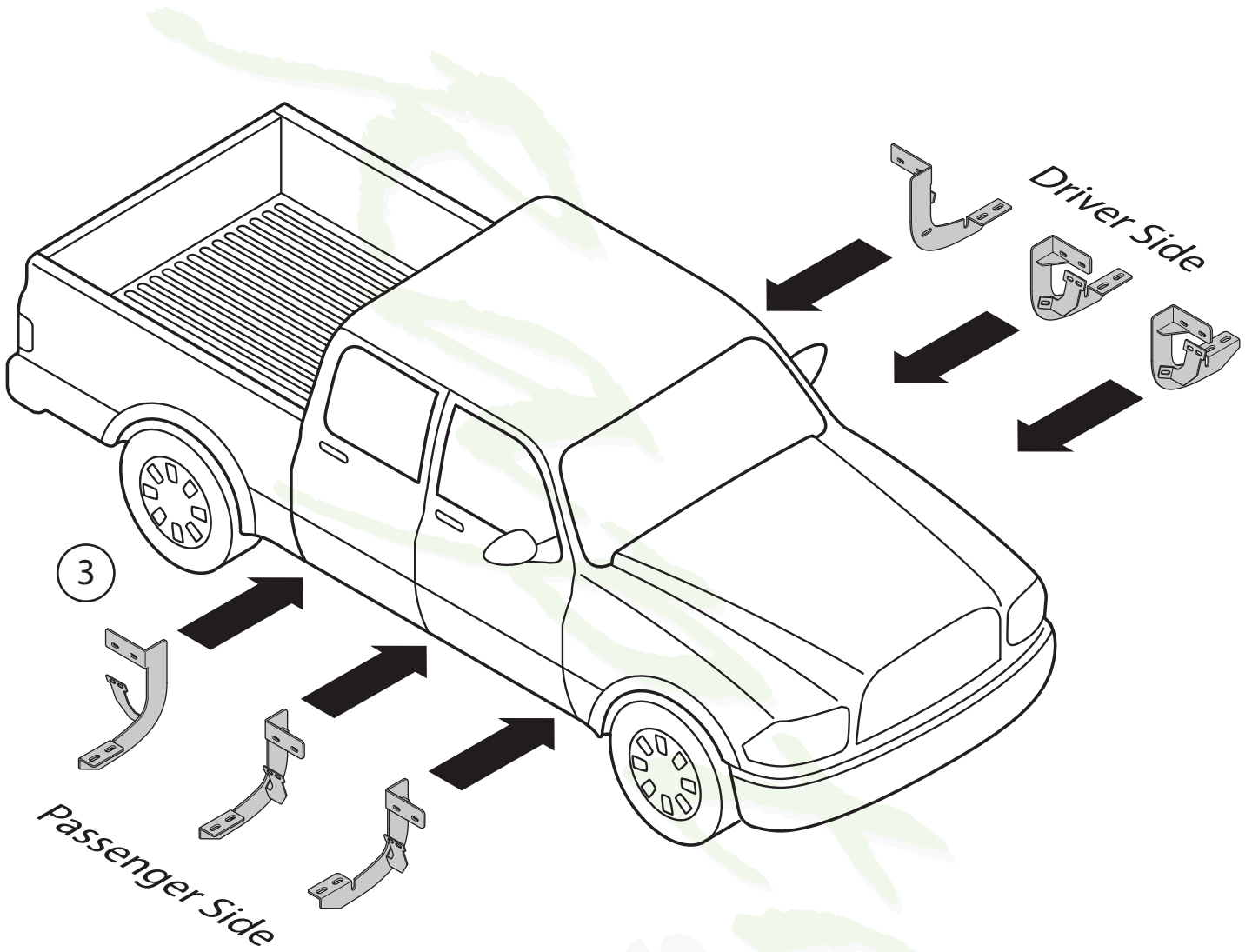

4. If threaded inserts already exist in Rocker Panel holes, fasten the top portion of the bracket by using (2) M8 x 30MM Head Head Bolts, (2) M8 Flat Washers and (2) M8 Lock Washers.

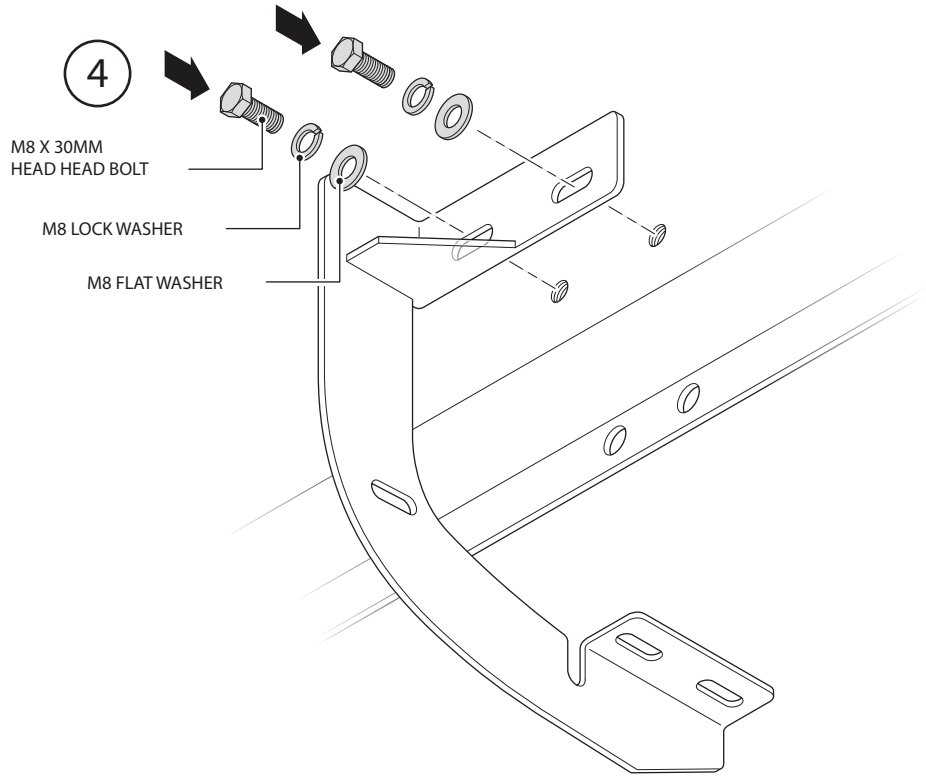

5. If threaded holes do not exist in rocker panel hex holes, you must install the M8 Bolt + M8 Nut Plate as shown. Install Plastic Retainer to ensure you do not drop the bolt plate into the rocker panel.

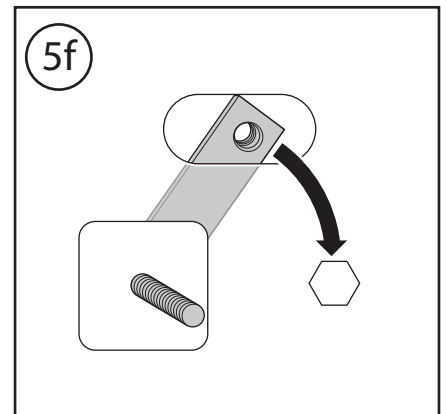
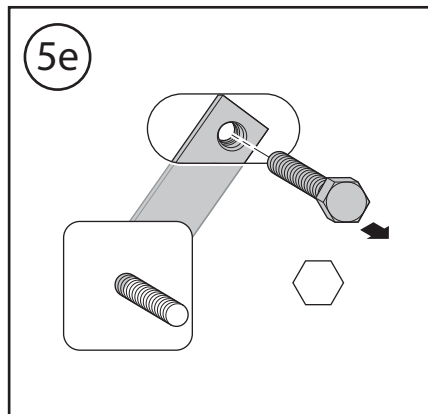
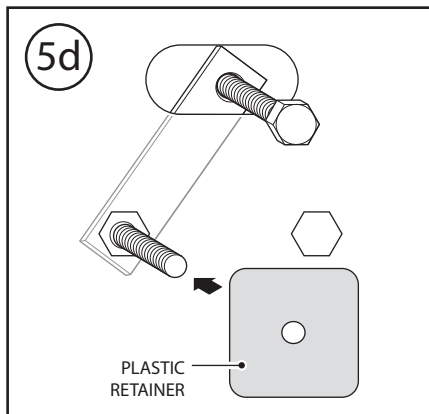
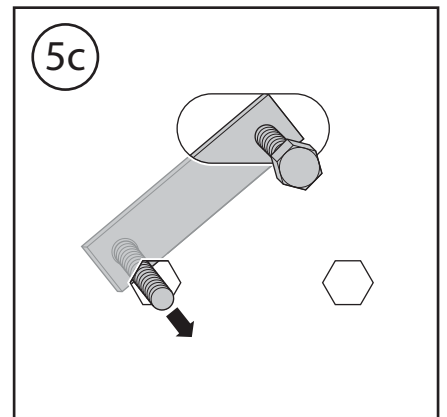
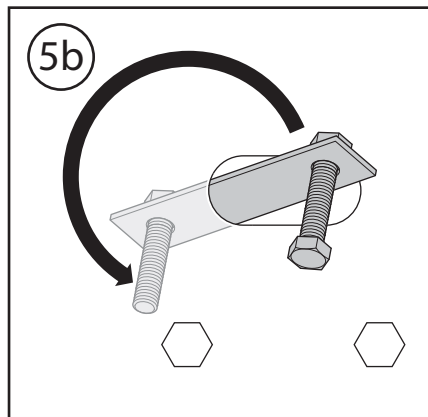
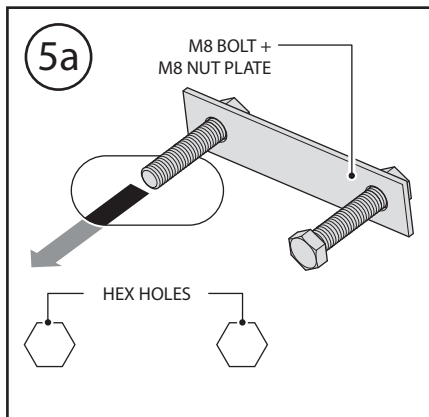

6. Fasten the bracket to the bolt side of the M8 Bolt + M8 Nut Plate by using (1) M8 Flat Washer, (1) M8 Lock Washer and (1) M8 Hex Head Nut.

Fasten the bracket to the nut side of the M8 Bolt + M8 Nut Plate by using (1) M8 x 35MM Hex Head Bolt, (1) M8 Lock Washer and (1) M8 Flat Washer.

7. Fasten the support brace to the rocker panel using (2) M8 x 30MM Hex Head Bolts, (2) M8 Flat Washers, (2) M8 Lock Washers and (2) M8 Hex Head Nuts.

8. Fasten the support brace to each bracket using (1) M8 x 30MM Hex Head Bolt (2) M8 Flat Washers, (1) M8 Lock Washer and (1) M8 Hex Head Nut.

9. Repeat these steps for driver side installation. When everything is in place, everything must be tightened. See page 1 for torque specifications.

