

1904-0367BT

5" TREAD STEP

Raptor
Series

Components:



Front Bracket
Driver & Passenger Side
Qty 2



Center & Rear Brackets
Driver & Passenger Side
Qty 4

Hardware:



M8 x 30MM
Hex Head Bolt
Qty 12



M8 Hex Head Nuts
Qty 12



M8 Lock
Washer
Qty 24



M8 Flat
Washer
Qty 24

Tools Required:

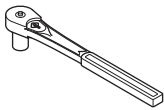

RATCHET

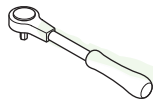

TORQUE
WRENCH



13MM SOCKET

Torque Specifications:

For Rocker Panel Mount Installations
M8 through M12 bolts and nuts are set to 15-20 ft lbs.

Note: When installing the brackets and boards, all hardware must be left loose until all the items are attached.

1. Remove all contents from the package and check running boards for any damage. Also, verify that all components and hardware listed above are included before you begin installation.

2. Read installation manual and installation drawing completely. Understand all brackets and bolts before installation.

3. Begin installation on the driver's side. Align Brackets as shown.

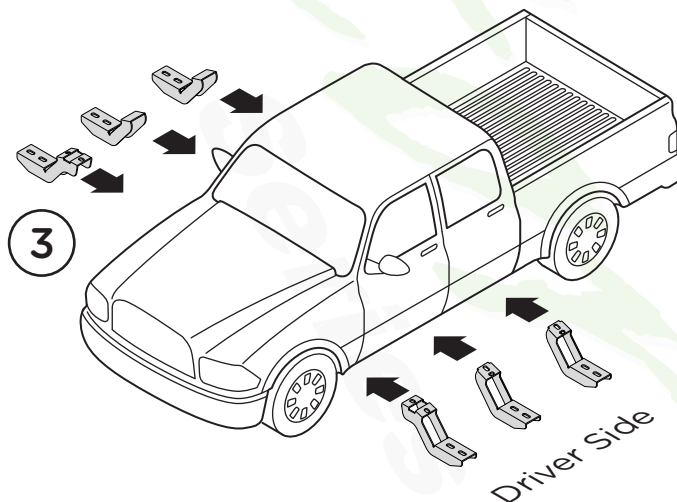

1904-0367BT

4. Align the Front, Center and Rear Driver's Side Brackets with the indicated holes located on the Rocker Panel of the vehicle.

5. Fasten the Front, Center and Rear Brackets to the Rocker Panel using two (2) M8 x 30MM Hex Head Bolts, two (2) M8 Flat Washers and two (2) M8 Lock Washers per bracket as shown.

6. Repeat these steps for passenger side installation. When all hardware is in place, everything must be tightened. See page 1 for torque specifications.

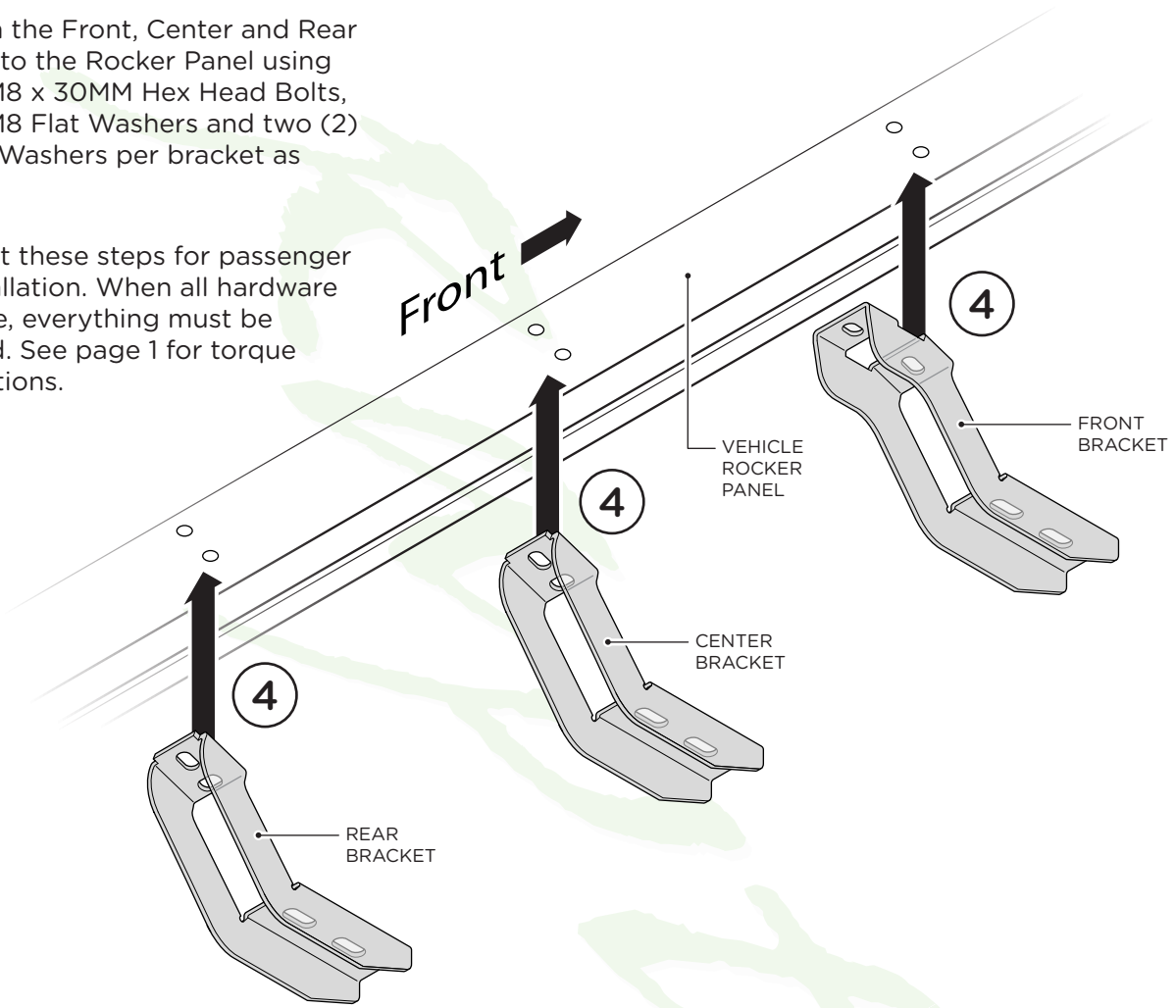

Center & Rear Bracket

Front Bracket

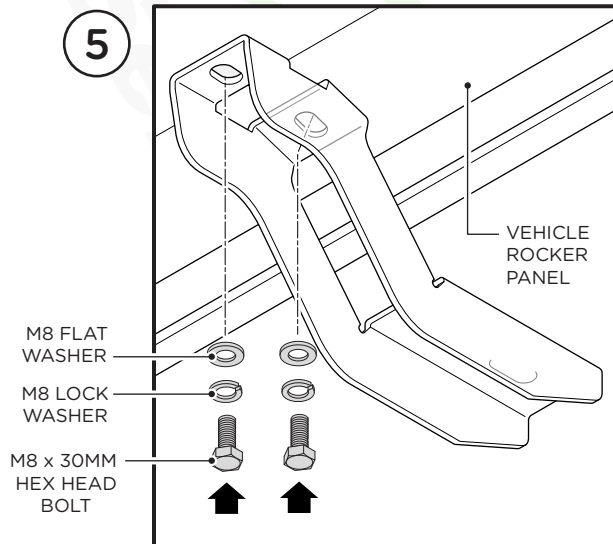
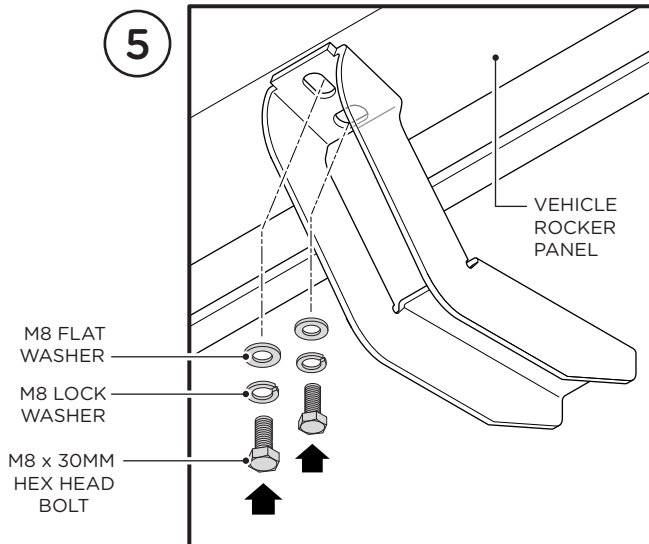

1. Place Running Board on brackets. Each running board is marked Driver and Passenger.

2. Slide M8 threaded studs in track system on the bottom of the Running Board to line up to mounting holes in each bracket.

3. Fasten Running Board on each bracket by using two (2) M8 Flat Washers, two (2) M8 Lock Washers and two (2) M8 Hex Head Nuts per bracket.

When all hardware is in place, everything must be tightened. Tighten until the split lock washer is flat between the M8 Flat Washer and M8 Hex Head Nut.

Repeat these steps for driver side installation.

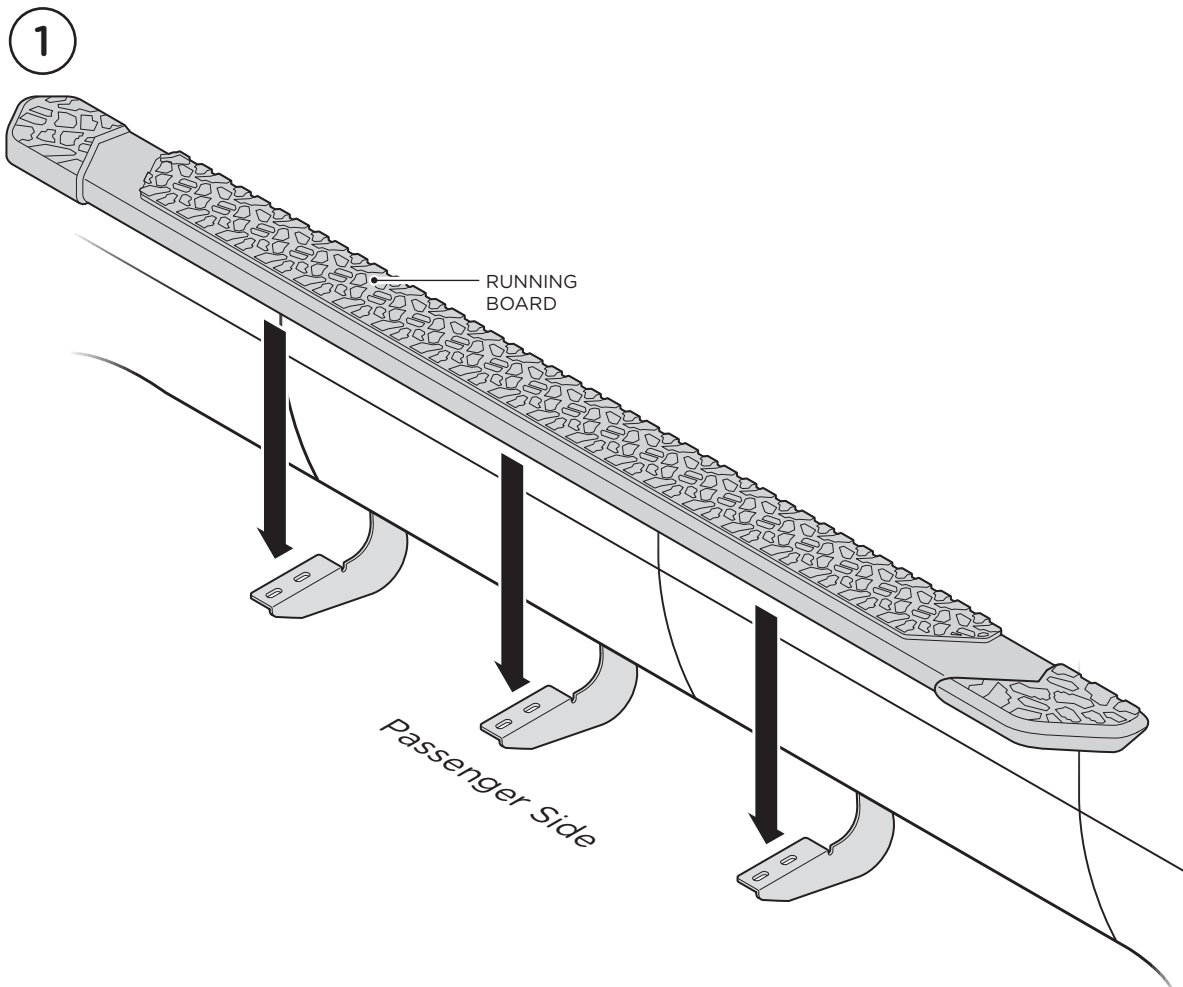
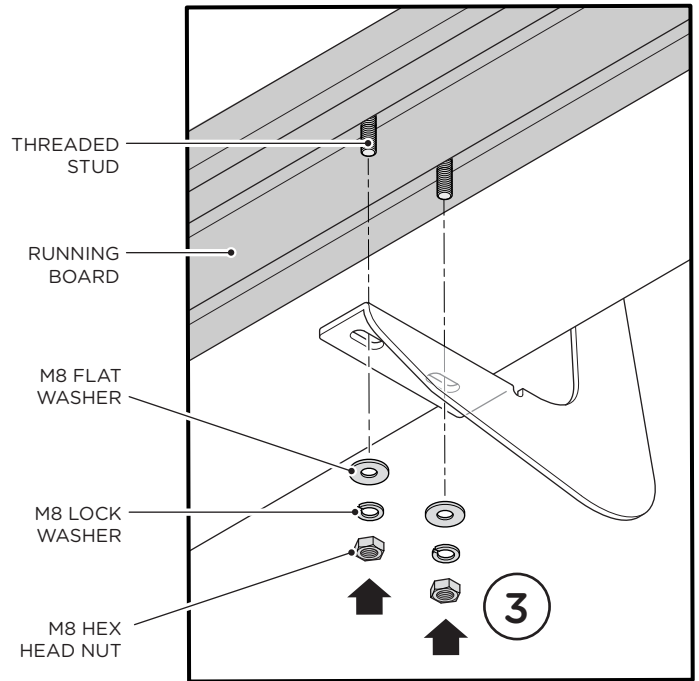

1904-0367BT