

# Raptor

Series



**CAUTION: Do not install damaged parts!!!**

# Raptor

## Series

## Easy Return / Easy Exchange

---

### **Want to return an item or exchange? Not satisfied with purchase?**

No problem. We strongly believe in service after the sale and we stand behind our products and our service to you, our valued customer. There is no problem we can't solve for you!

Items that have been installed and/or damaged after receipt, are no longer in new and ready-to-sell condition and cannot be refunded, replaced or exchanged unless it has a manufacturer defect or was damaged in shipping. In addition, we cannot accept return on items that are not in the original packaging. Items returned in poor condition or having parts missing will not be credited.

**Please note: Your request for return or replacement must be initiated within 30 days of delivery of your merchandise.**

### **Did your order arrive damaged?**

Please do not install damaged products. Contact the company you purchased your product from as soon as possible and notify them of the damages. They will make arrangements with you to assist with the problem.

### **Did you order the wrong part or receive the wrong item?**

Don't worry. From time to time human error can result in problems with ordering or shipping. Contact the company you purchased your product from as soon as you notice the error. Every company has their own policy on returning parts that have been ordered incorrectly or shipped incorrectly.

# 5" TREAD STEP



## Components:

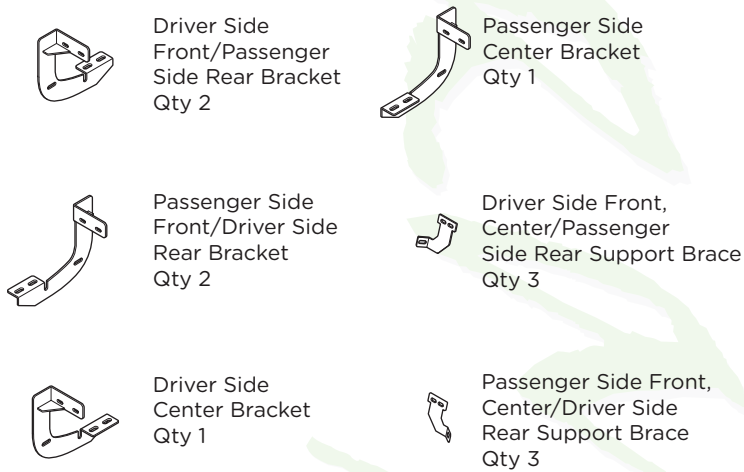

## Hardware:

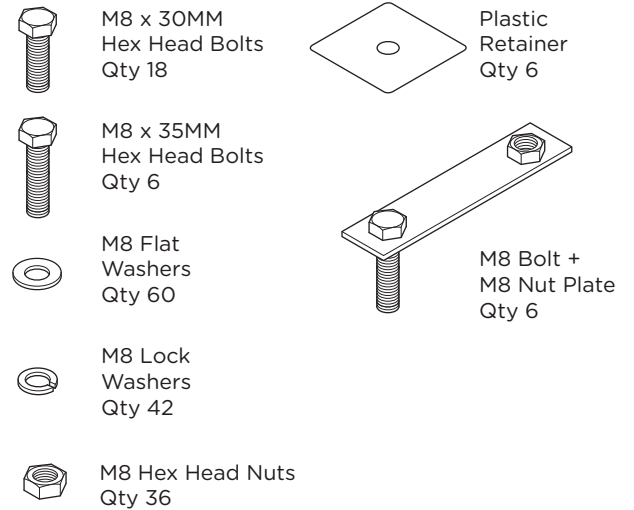

## Tools Required:

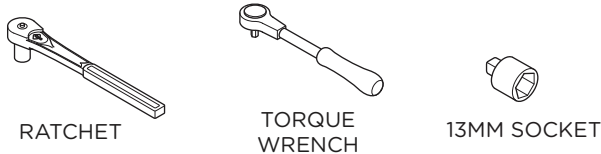

## Torque Specifications:

For Rocker Panel Mount Installations  
M8 through M12 bolts and nuts are set to 15-20 ft lbs.

**Note: When installing the brackets and boards, all hardware must be left loose until all the items are attached.**

1. Remove all contents from the package and check running boards for any damage. Also, verify that all components and hardware listed above are included before you begin installation.

2. Locate factory holes in six (6) places underneath body mount.

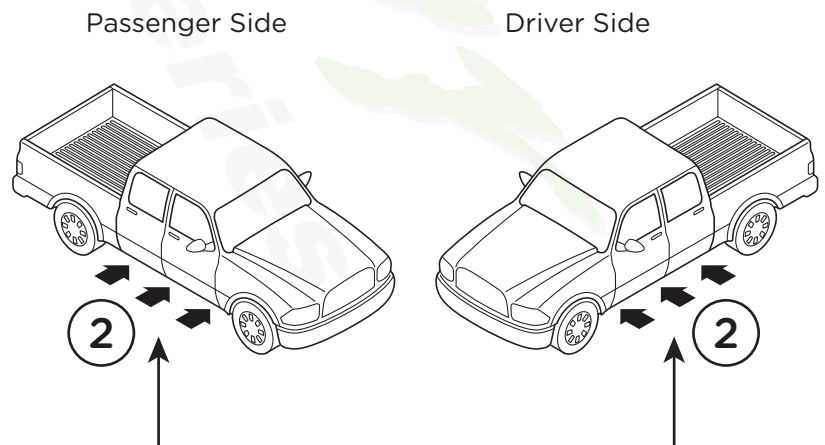
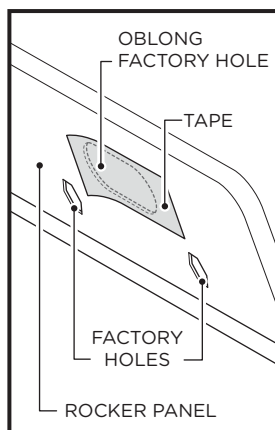

**3.** Begin installation on passenger side. Position Front Bracket, Center Bracket and Rear Bracket as shown along passenger side.

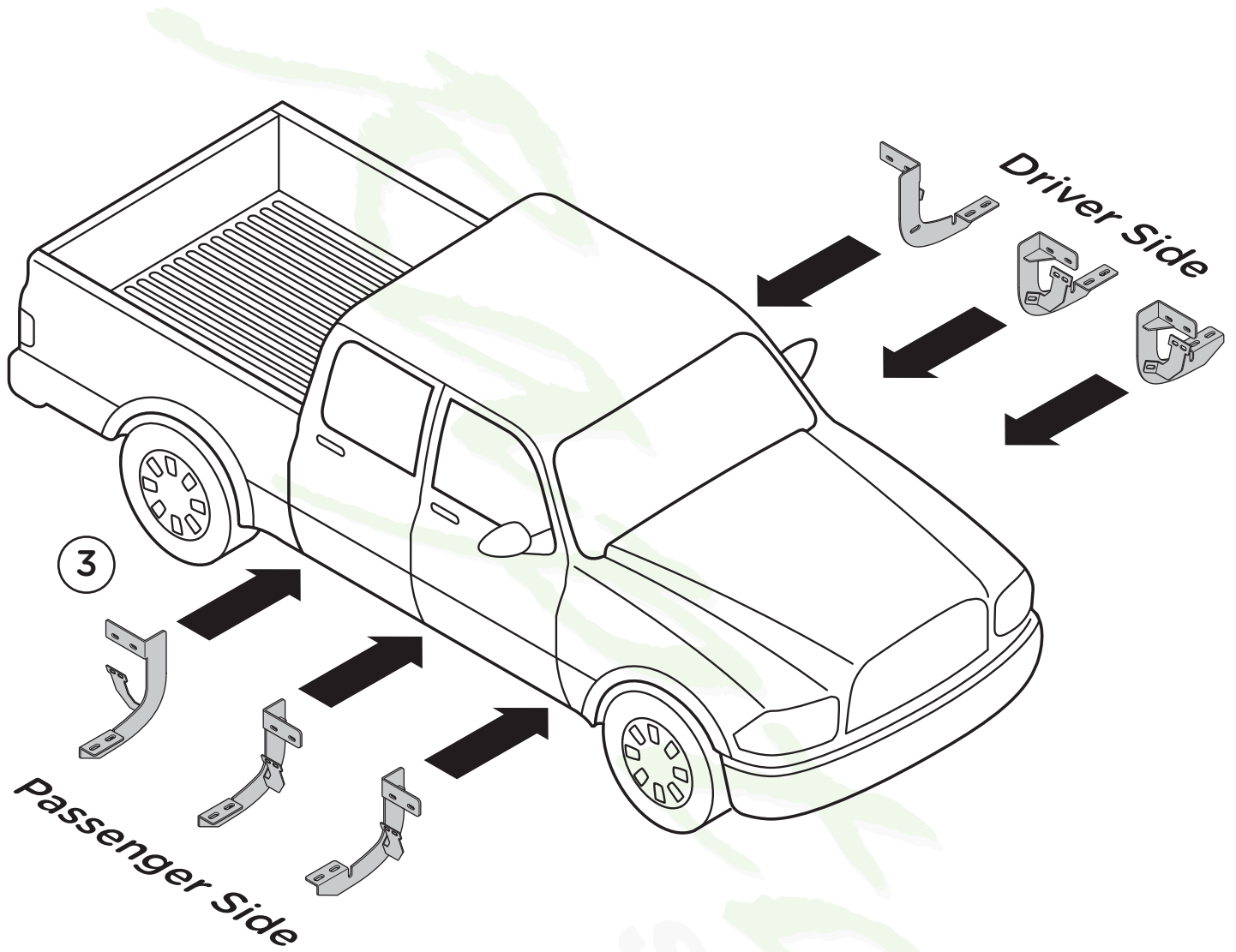

**4.** If threaded inserts already exist in Rocker Panel holes, fasten the top portion of the bracket by using (2) M8 x 30MM Head Head Bolts, (2) M8 Flat Washers and (2) M8 Lock Washers.

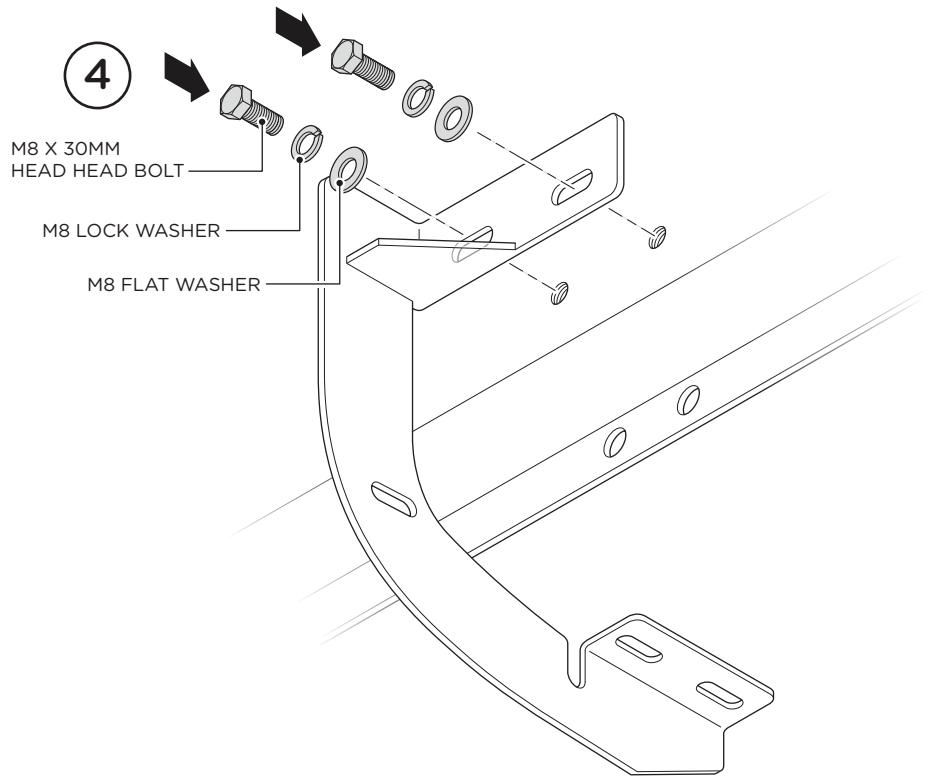

**5.** If threaded holes do not exist in rocker panel hex holes, you must install the M8 Bolt + M8 Nut Plate as shown. Install Plastic Retainer to ensure you do not drop the bolt plate into the rocker panel.

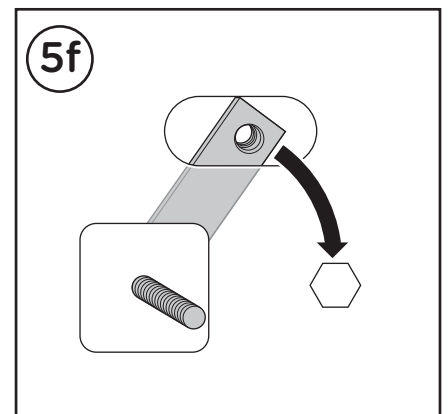
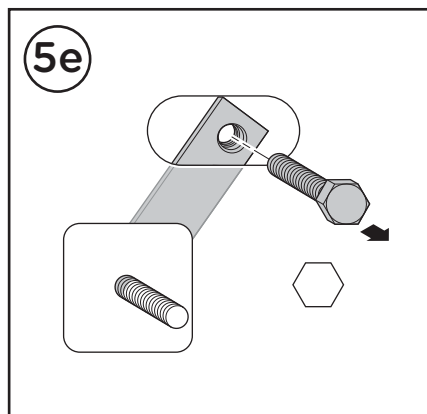
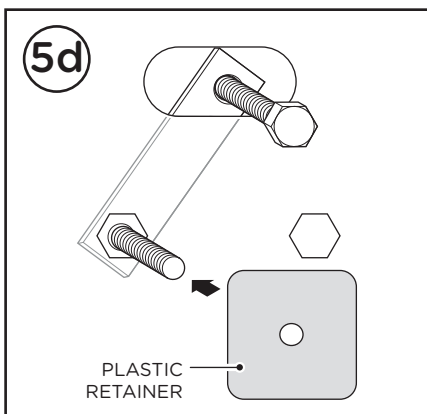
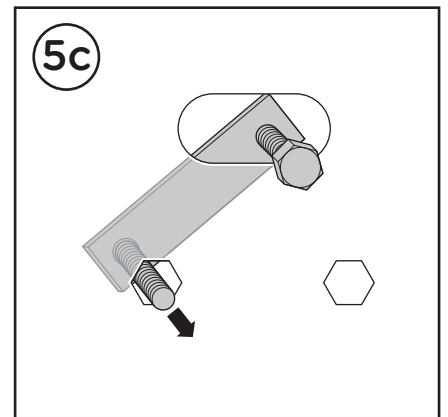
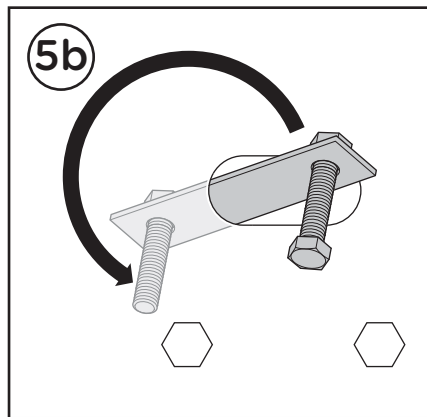
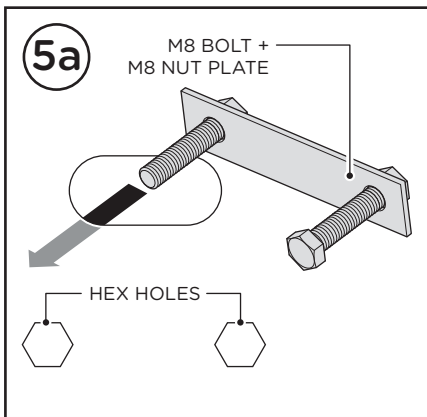

**6.** Fasten the bracket to the bolt side of the M8 Bolt + M8 Nut Plate by using (1) M8 Flat Washer, (1) M8 Lock Washer and (1) M8 Hex Head Nut.

Fasten the bracket to the nut side of the M8 Bolt + M8 Nut Plate by using (1) M8 x 35MM Hex Head Bolt, (1) M8 Lock Washer and (1) M8 Flat Washer.

**7.** Fasten the support brace to the rocker panel using (2) M8 x 30MM Hex Head Bolts, (2) M8 Flat Washers, (2) M8 Lock Washers and (2) M8 Hex Head Nuts.

**8.** Fasten the support brace to each bracket using (1) M8 x 30MM Hex Head Bolt (2) M8 Flat Washers, (1) M8 Lock Washer and (1) M8 Hex Head Nut.

**9.** Repeat these steps for driver side installation. When everything is in place, everything must be tightened. See page 1 for torque specifications.

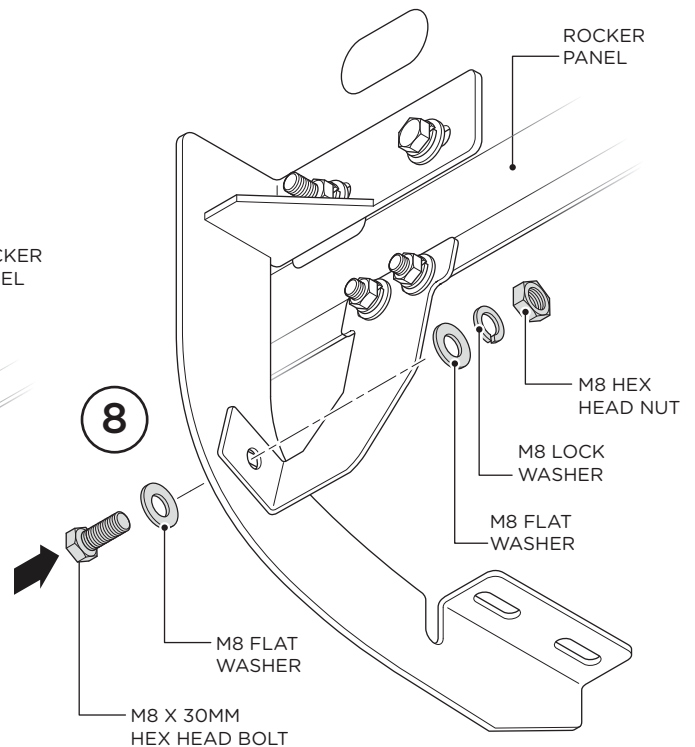
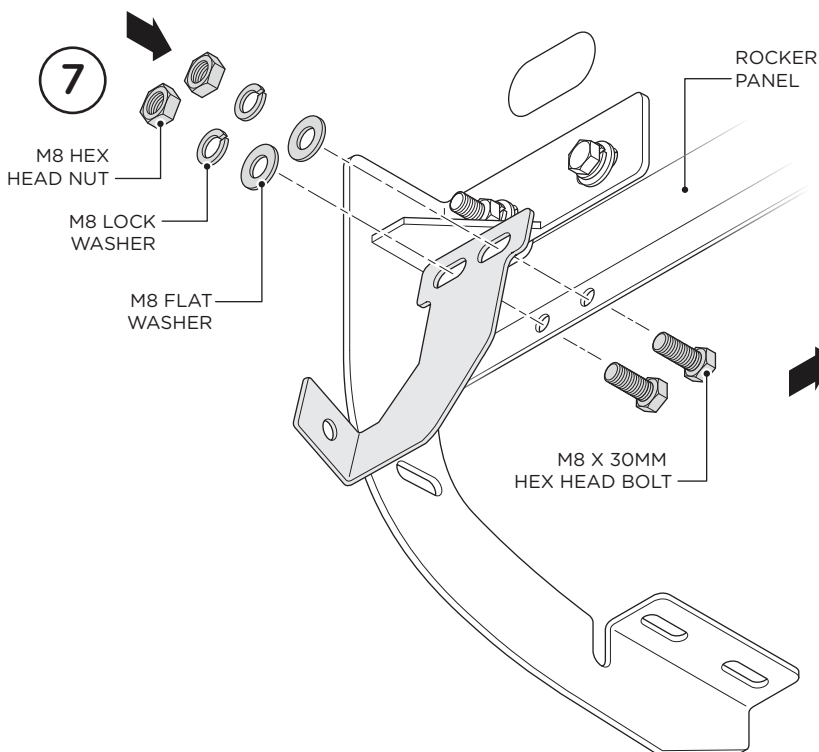
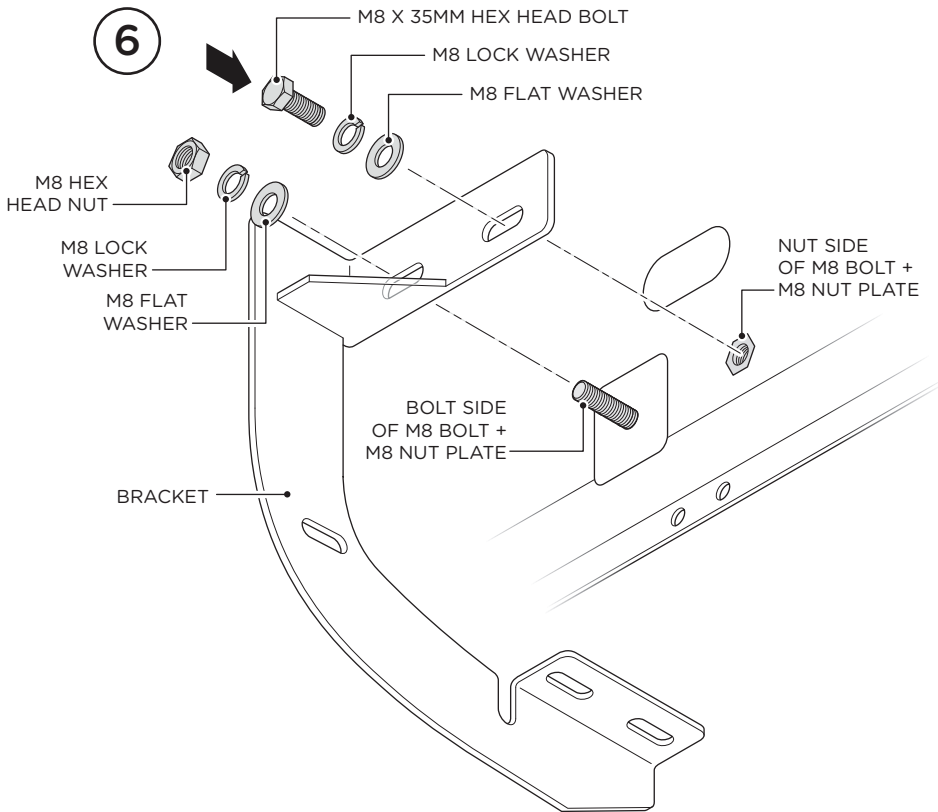

**1.** Place Running Board on brackets. Each running board is marked Driver and Passenger.

**2.** Slide M8 threaded studs in track system on the bottom of the Running Board to line up to mounting holes in each bracket.

**3.** Fasten Running Board on each bracket by using two (2) M8 Flat Washers, two (2) M8 Lock Washers and two (2) M8 Hex Head Nuts per bracket.

When all hardware is in place, everything must be tightened. Tighten until the split lock washer is flat between the M8 Flat Washer and M8 Hex Head Nut.

Repeat these steps for driver side installation.

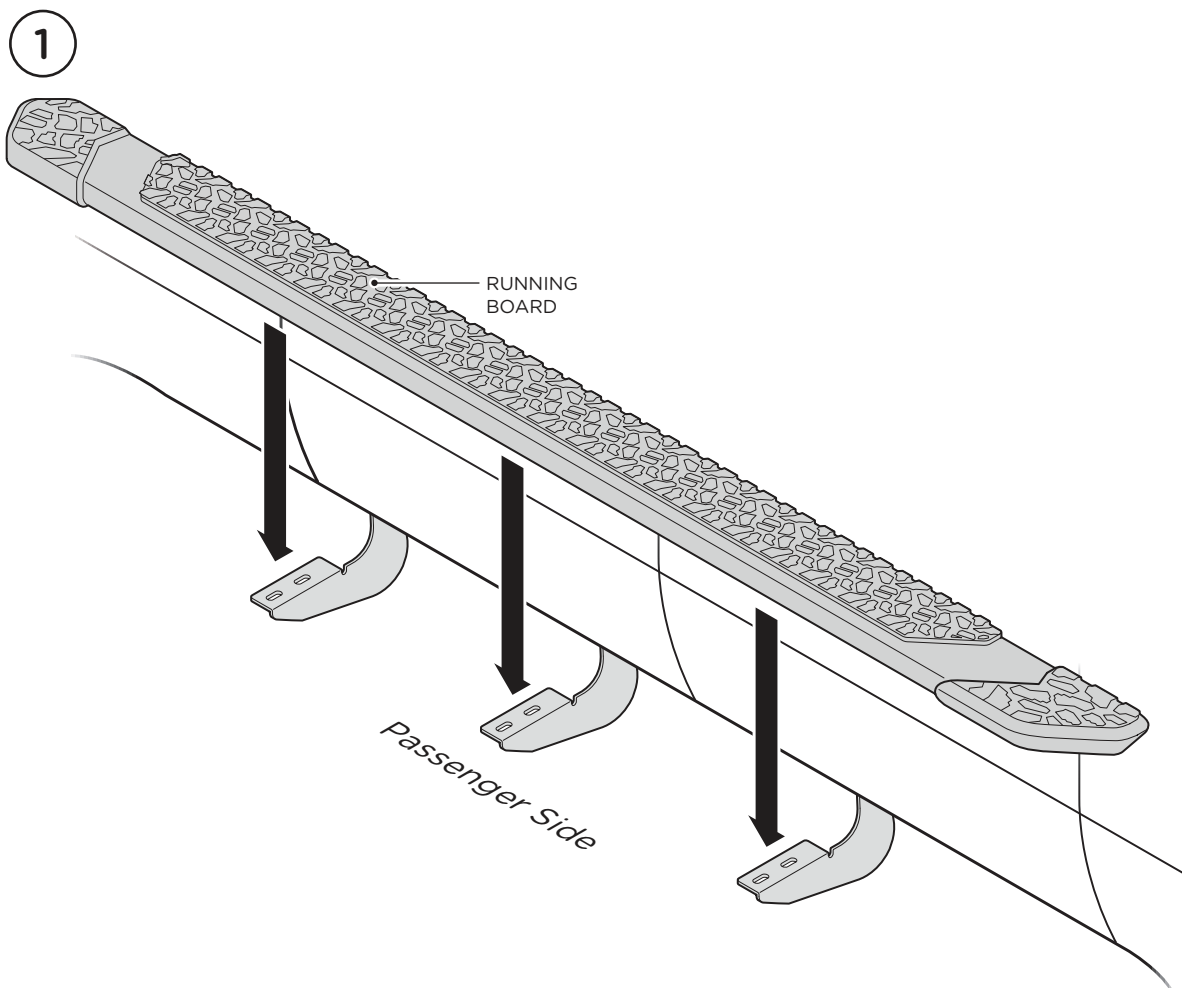
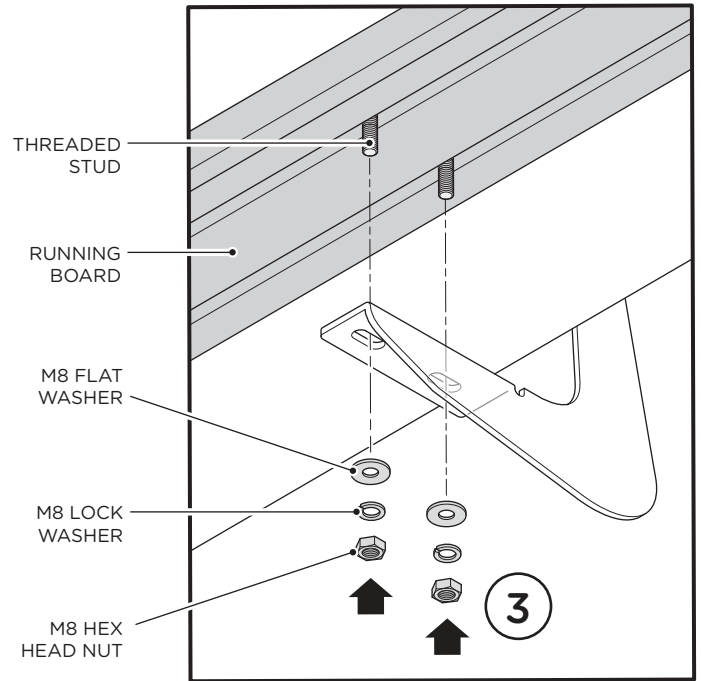

1902-0062BT