

# BRACKET KIT

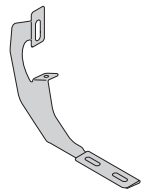

## Components:



Mounting Brackets  
Qty 6

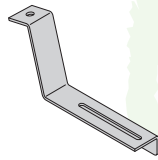

Diesel Front/Center  
Lower Bracket  
Qty 2



Diesel Front/Center  
Upper Bracket  
Qty 2

## Hardware:



M8 x 30mm  
Hex Head Bolts  
Qty 12



M8 Hex Head  
Nut  
Qty 18



M10 Lock  
Washers  
Qty 2



M8 Flat  
Washers  
Qty 30



Nylon  
Washer  
Qty 6



M8 Lock  
Washers  
Qty 24



M10 x 30mm  
Hex Head Bolts  
Qty 2



U-Nut Clip  
Qty 6



M10 Flat Washers  
Qty 2

## Tools Required:

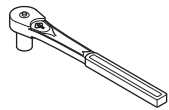

RATCHET

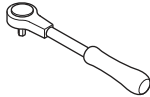

TORQUE  
WRENCH



13MM SOCKET



17MM SOCKET

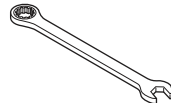

13MM RATCHET  
WRENCH

## Torque Specifications:

For Rocker Panel Mount Installations  
M8 through M12 bolts and nuts are set to 15-20 ft lbs.

**Note: When installing the brackets and boards, all hardware must be left loose until all the items are attached.**

1. Remove all contents from the package and check running boards for any damage. Also, verify that all components and hardware listed above are included before you begin installation.
2. Read installation manual and installation drawing completely. Understand all brackets and bolts before installation.
3. Existing mounting holes are located on the interior wall of the rocker panel. These mounting holes will be used per the following instruction.

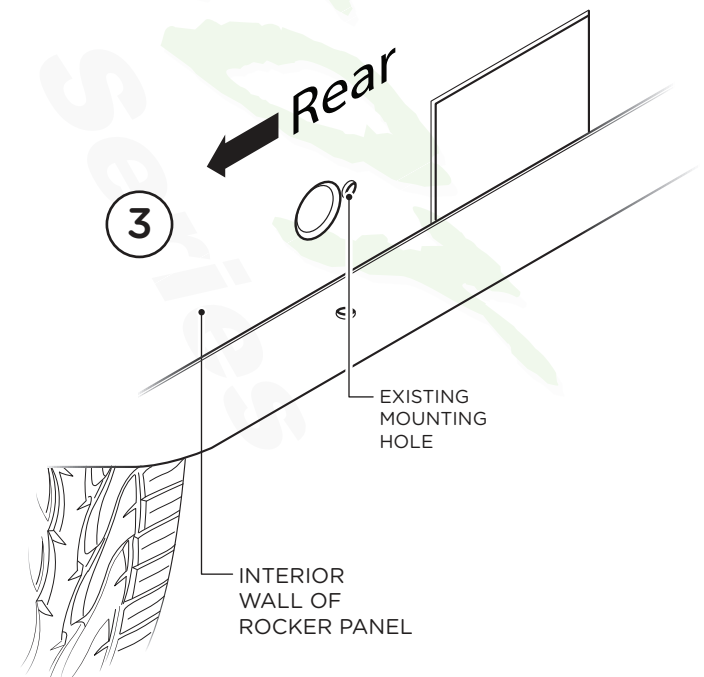

**4.** On driver side of vehicle, align Front, Center and Rear Brackets as shown.

4

**5.** Driver side Mounting Bracket cradles will face the front of the truck.

**6.** If specified holes in the wall of the rocker panel are not threaded, remove plastic plug (6a and 6b) and insert U-Nut Clip so that the threads are facing away from you (6c and 6d). Fasten using one (1) M8 x 30 mm Hex Head Bolt, one (1) M8 Flat Washer and one (1) M8 Lock Washer.

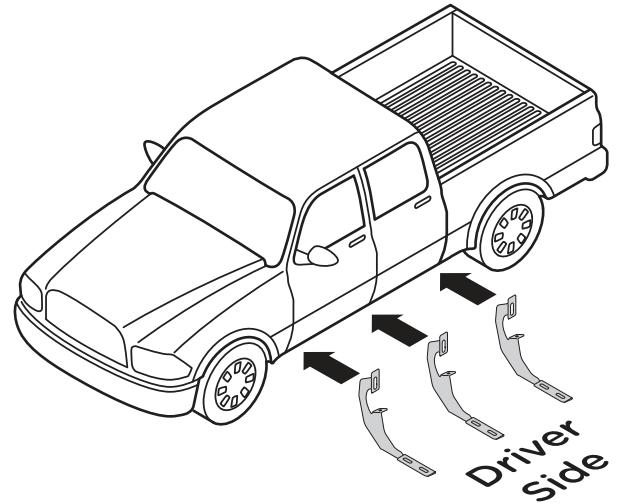

**7.** Complete installation of brackets by placing one (1) Nylon Washer between lower mounting point and pinch weld. Then fasten using one (1) M8 x 30 mm Hex Head Bolt, two (2) M8 Flat Washers, one (1) M8 Lock Washer and one (1) M8 Hex Head Nut. Repeat this procedure for remaining brackets.

**8.** For gas models, repeat these steps for passenger side installation. Proceed to next step for diesel instructions.

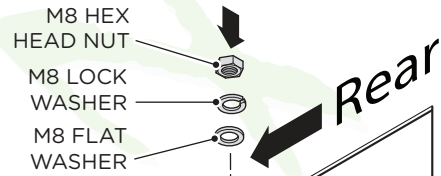
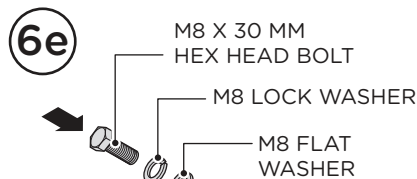
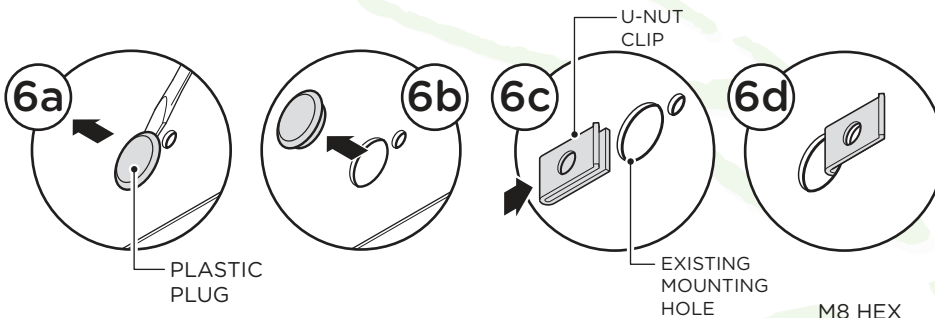

7

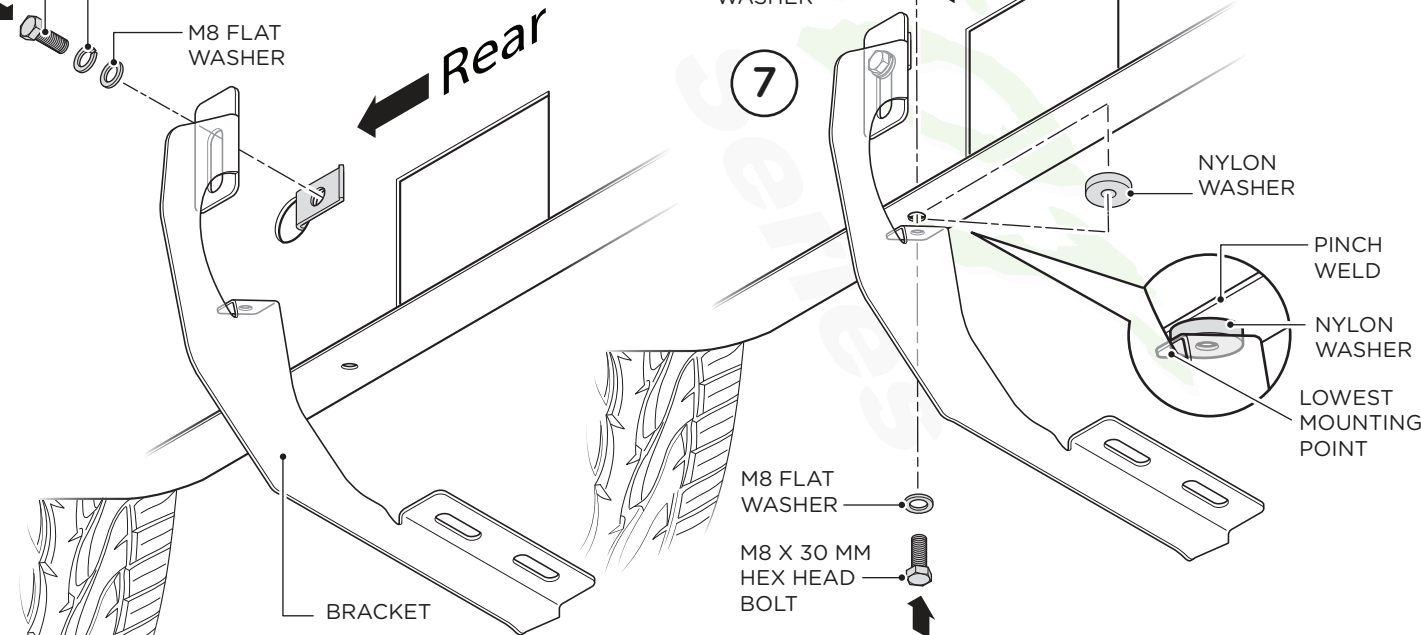

## Installing on a Diesel Model with DEF Tank

**9.** If installing on a diesel model with DEF tank, you must use Diesel Front/Center Upper/Lower Brackets on the passenger front and center mounting location.

Slide Diesel Front/Center Upper Bracket between the DEF tank and the rocker panel (9a).

The nut on this bracket will line up with the hole on the pinch weld and the vertical mounting point will be aligned with the threaded hole in the rocker panel (9b). If no threaded hole exists, please install M8 U-Nut Clip.

Fasten using one (1) M8x 30 mm Hex Head Bolt, one (1) M8 Lock Washer and one (1) M8 Flat Washer (9c).

Next, hold the Diesel Front/Center Lower Bracket to the bottom of the pinch weld and attach to Diesel Front/Center Upper Bracket using one (1) M10x 30 mm Hex Head Bolt, one (1) M10 Lock Washer and one (1) M10 Flat Washer (9d).

When all hardware is in place, everything must be tightened. See page 1 for torque specifications.

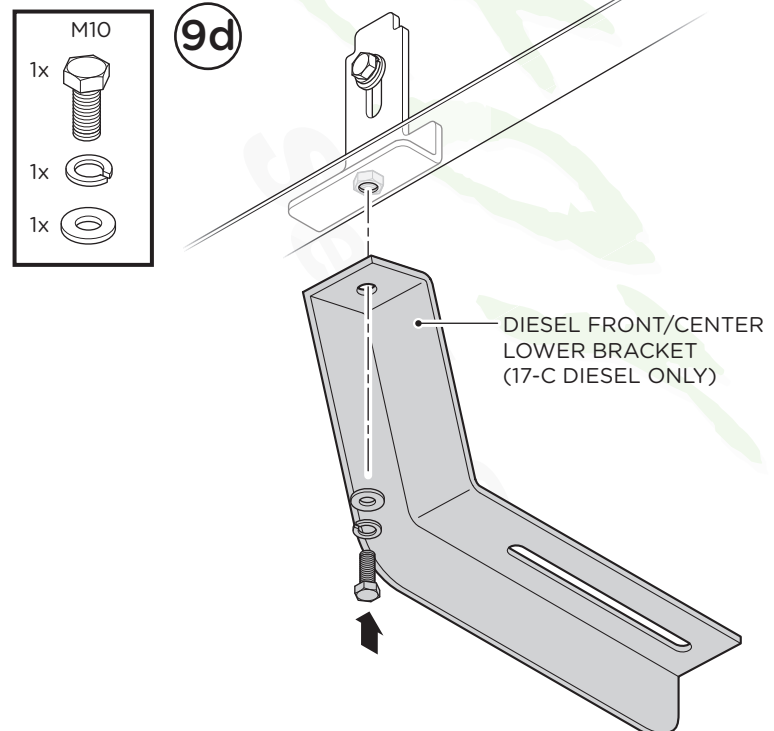
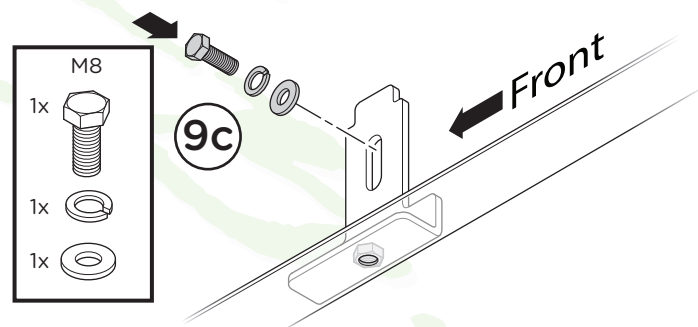
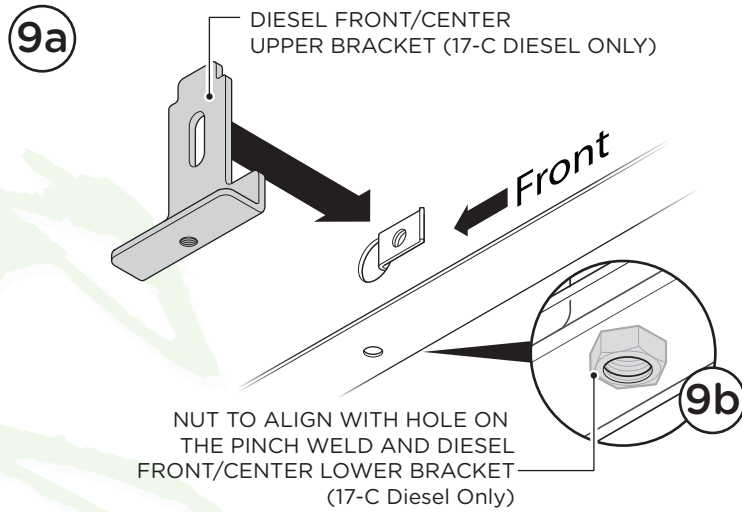

# 5" TREAD STEP

1. Place Running Board on brackets. Each running board is marked Driver and Passenger.

2. Slide M8 threaded studs in track system on the bottom of the Running Board to line up to mounting holes in each bracket.

3. Fasten Running Board on each bracket by using two (2) M8 Flat Washers, two (2) M8 Lock Washers and two (2) M8 Hex Head Nuts per bracket.

When all hardware is in place, everything must be tightened. Tighten until the split lock washer is flat between the M8 Flat Washer and M8 Hex Head Nut.

Repeat these steps for driver side installation.

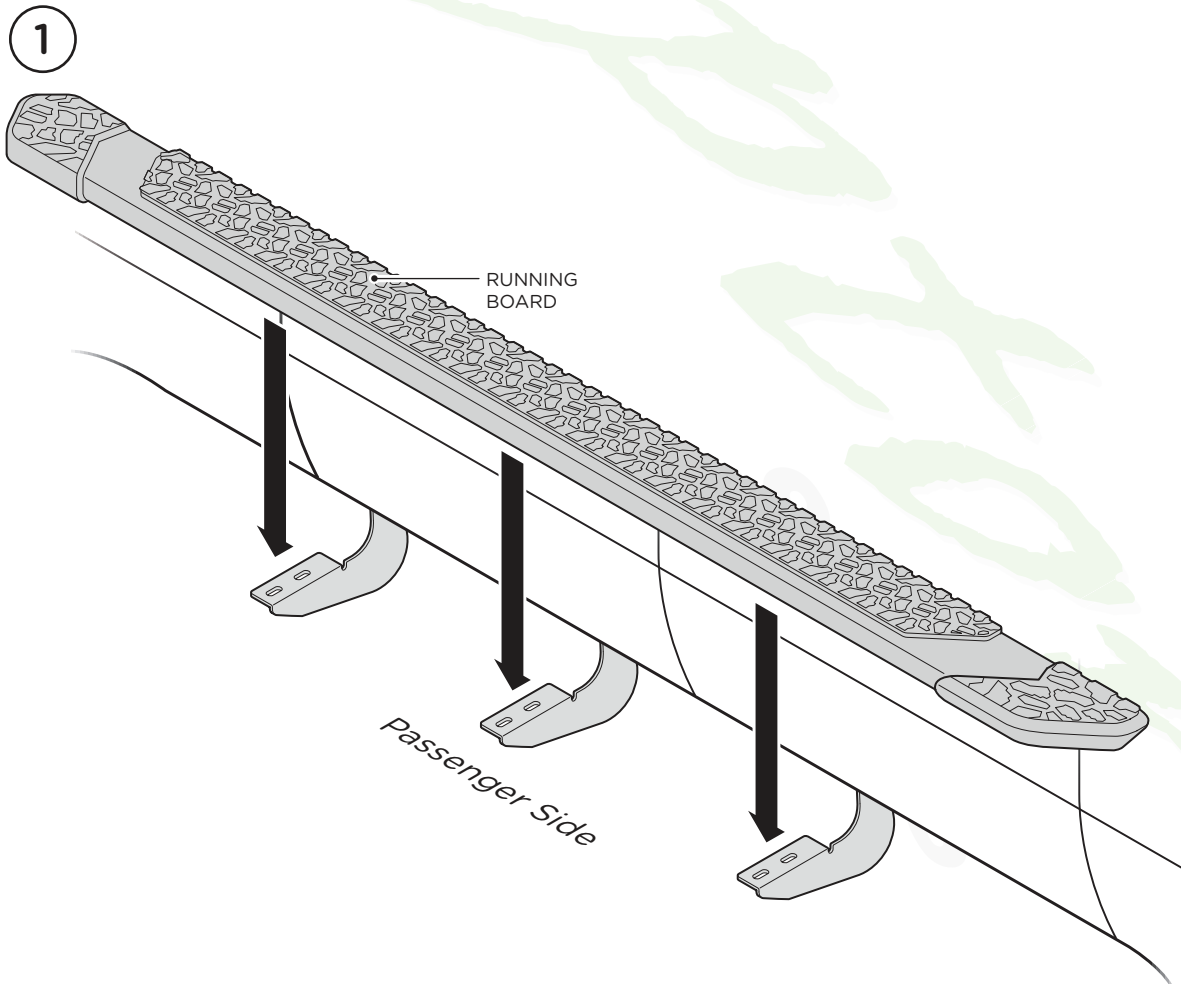
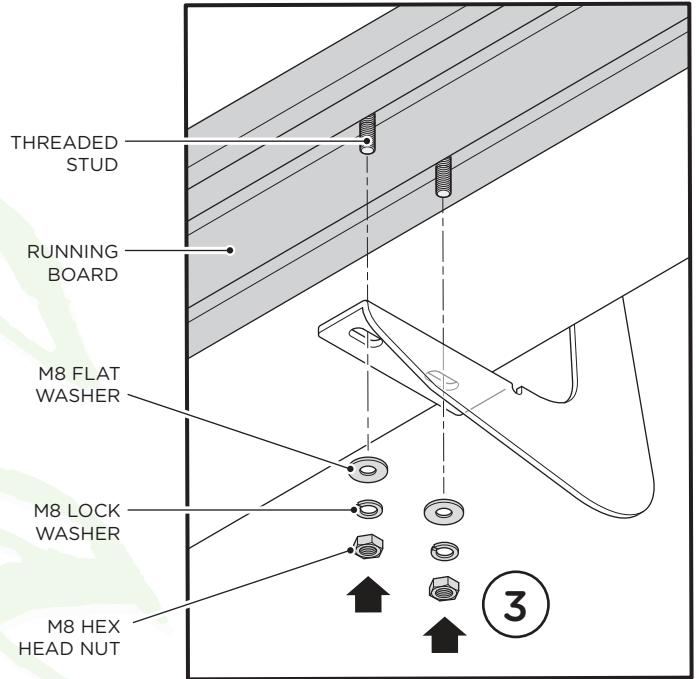

[View other running boards and step bars made by Raptor Series on our website.](#)