

# 6" OEM RUNNING BOARD



## Components:



Front Bracket  
Driver & Passenger Side  
Qty 2



Center & Rear Brackets  
Driver & Passenger Side  
Qty 4

## Hardware:



M8 x 30MM  
Hex Head Bolt  
Qty 12



M8 Hex Head Nuts  
Qty 12



M8 Lock  
Washer  
Qty 24



M8 Flat  
Washer  
Qty 24

## Tools Required:

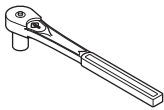

RATCHET

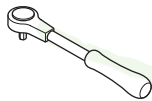

TORQUE  
WRENCH



13MM SOCKET

## Torque Specifications:

For Rocker Panel Mount Installations  
M8 through M12 bolts and nuts are set to 15-20 ft lbs.

**Note: When installing the brackets and boards, all hardware must be left loose until all the items are attached.**

**1.** Remove all contents from the package and check running boards for any damage. Also, verify that all components and hardware listed above are included before you begin installation.

**2.** Read installation manual and installation drawing completely. Understand all brackets and bolts before installation.

**3.** Begin installation on the driver's side. Align Brackets as shown.

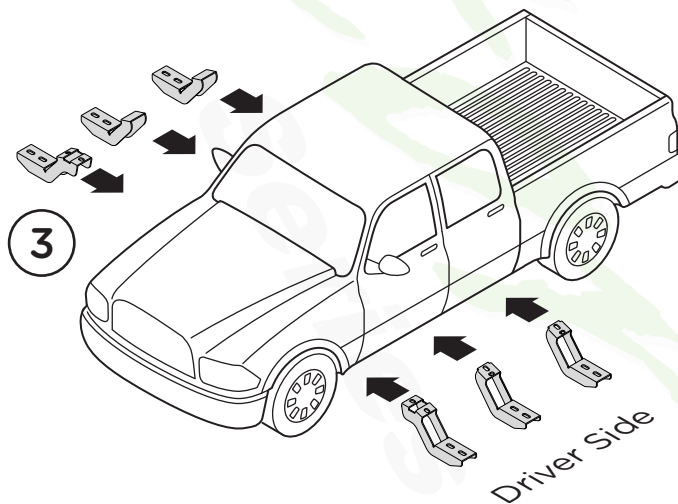

**4.** Align the Front, Center and Rear Driver's Side Brackets with the indicated holes located on the Rocker Panel of the vehicle.

**5.** Fasten the Front, Center and Rear Brackets to the Rocker Panel using two (2) M8 x 30MM Hex Head Bolts, two (2) M8 Flat Washers and two (2) M8 Lock Washers per bracket as shown.

**6.** Repeat these steps for passenger side installation. When all hardware is in place, everything must be tightened. See page 1 for torque specifications.

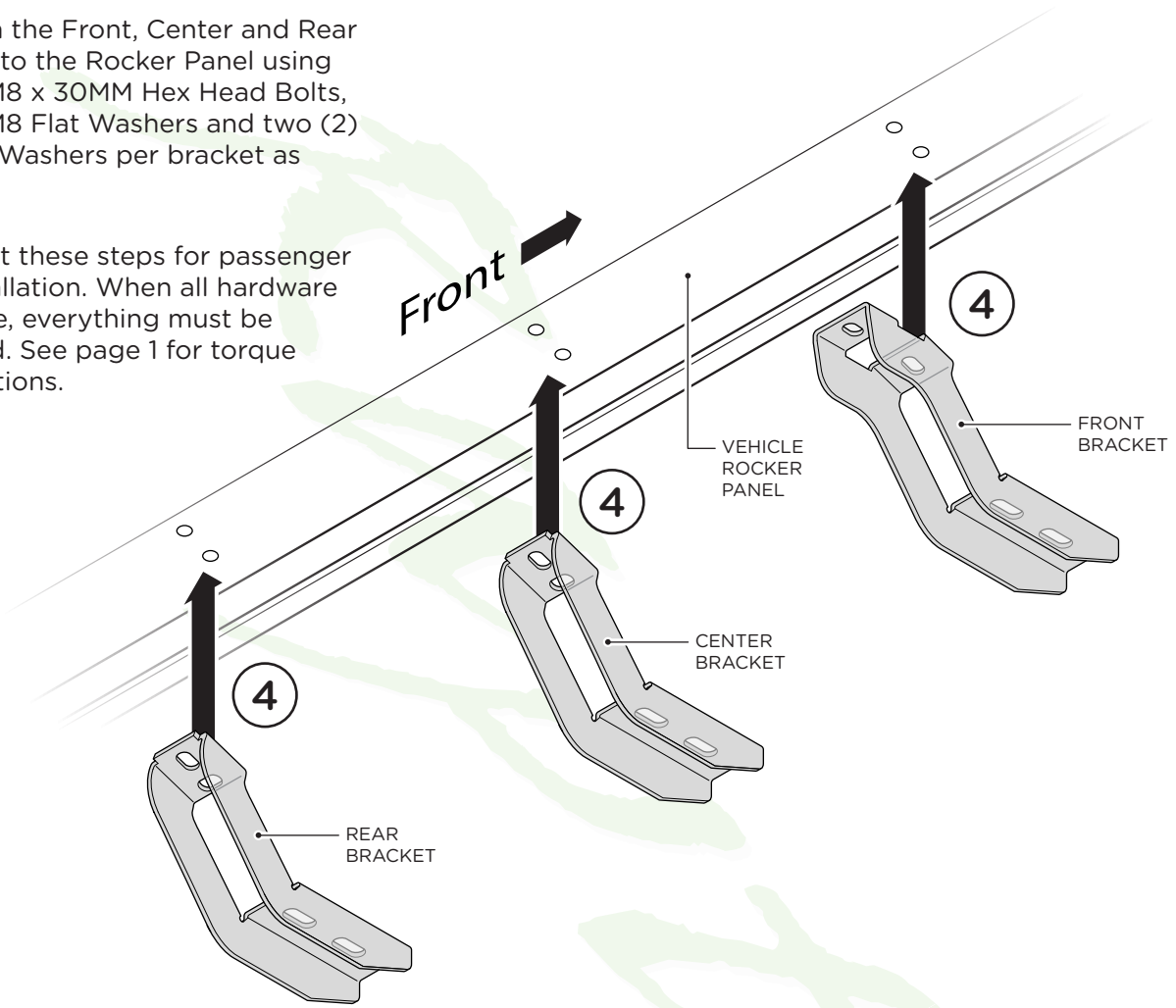

**Center & Rear Bracket**

**Front Bracket**

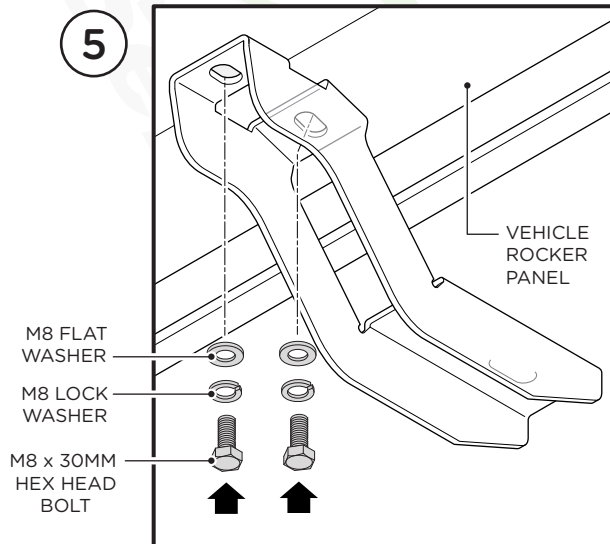
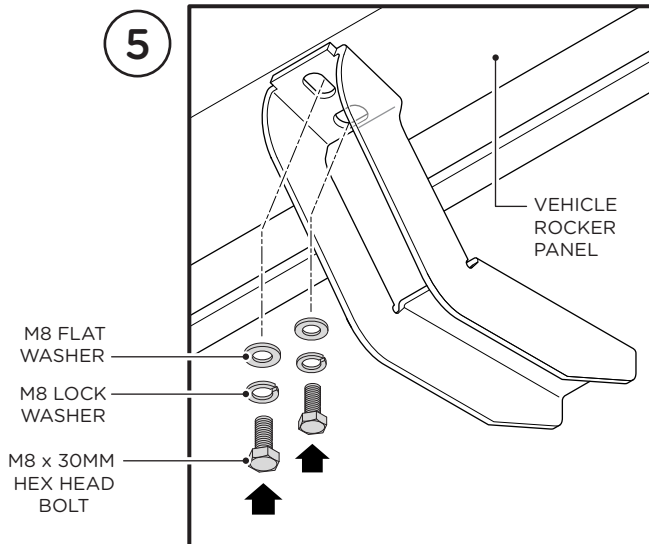

# 6" OEM RUNNING BOARD

*Raptor*  
Series

**1.** Place Running Board on brackets. Each running board is marked Driver and Passenger.

**2.** Slide M8 threaded studs in track system on the bottom of the Running Board to line up to mounting holes in each bracket.

**3.** Fasten Running Board on each bracket by using two (2) M8 Flat Washers, two (2) M8 Lock Washers and two (2) M8 Hex Head Nuts per bracket.

When all hardware is in place, everything must be tightened. Tighten until the split lock washer is flat between the M8 Flat Washer and M8 Hex Head Nut.

Repeat these steps for driver side installation.

