

1701-0052, 1701-0052BT

6" OEM RUNNING BOARD

Raptor Series

Components:

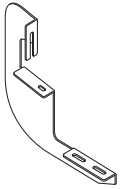

Mounting Brackets
Qty 6

Hardware:



M8 x 30 mm
Hex Head Bolts
Qty 12



M8 Hex Head
Nuts
Qty 12



M8 Flat
Washers
Qty 24



M8 Lock
Washers
Qty 24

Tools Required:

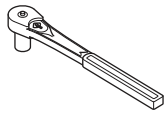

RATCHET

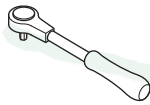

TORQUE
WRENCH



13MM SOCKET

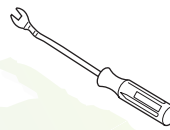

RETAINER
REMOVAL TOOL

Torque Specifications:

For Rocker Panel Mount Installations
M8 through M12 bolts and nuts are set to 15-20 ft lbs.

Note: When installing the brackets and bars, all hardware must be left loose until all the items are attached.

1. Remove all contents from the package and check steps for any damage. Also, verify that all components and hardware listed above are included before you begin installation.
2. Read installation manual and installation drawing completely. Understand all brackets and bolts before installation.
3. Existing mounting holes are located on the interior wall of the rocker panel. These mounting holes will be used per the following instruction.

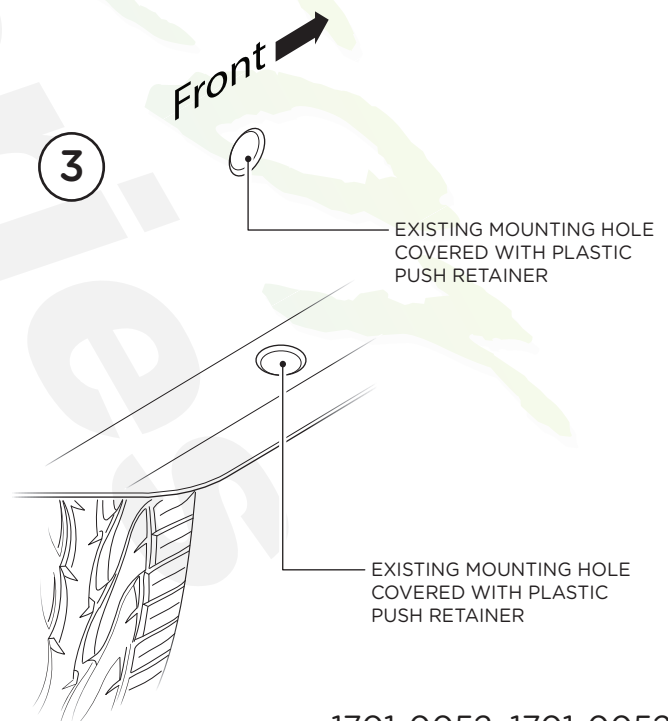

1701-0052, 1701-0052BT

4. On driver side of vehicle, align Front, Center and Rear Brackets as shown.

5. Driver side bracket cradles face to the front of the truck.

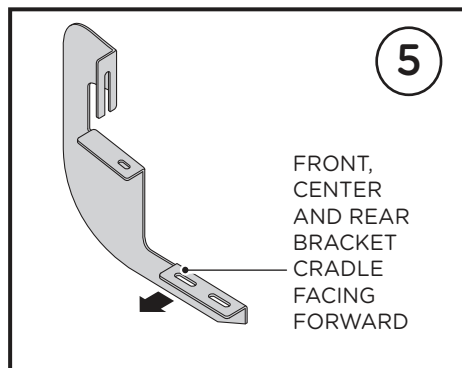
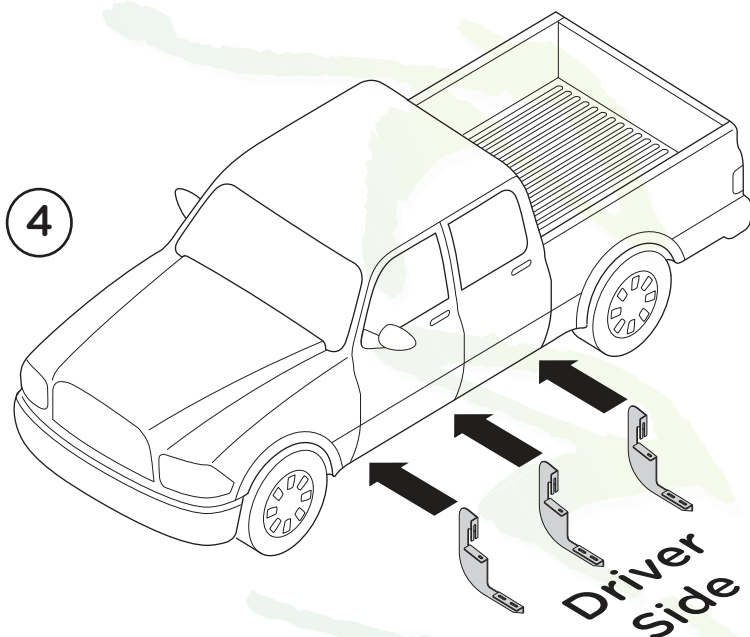

6. Starting from the front of the cab, locate the first, third and fifth sets of plastic push retainers on the rocker panel for crew cab models. Double cab models will use the first, second and fourth sets of mounting points.

Remove the retainers using a Retainer Removal Tool. This will expose threaded inserts on the rocker panel used for mounting the brackets to the vehicle.

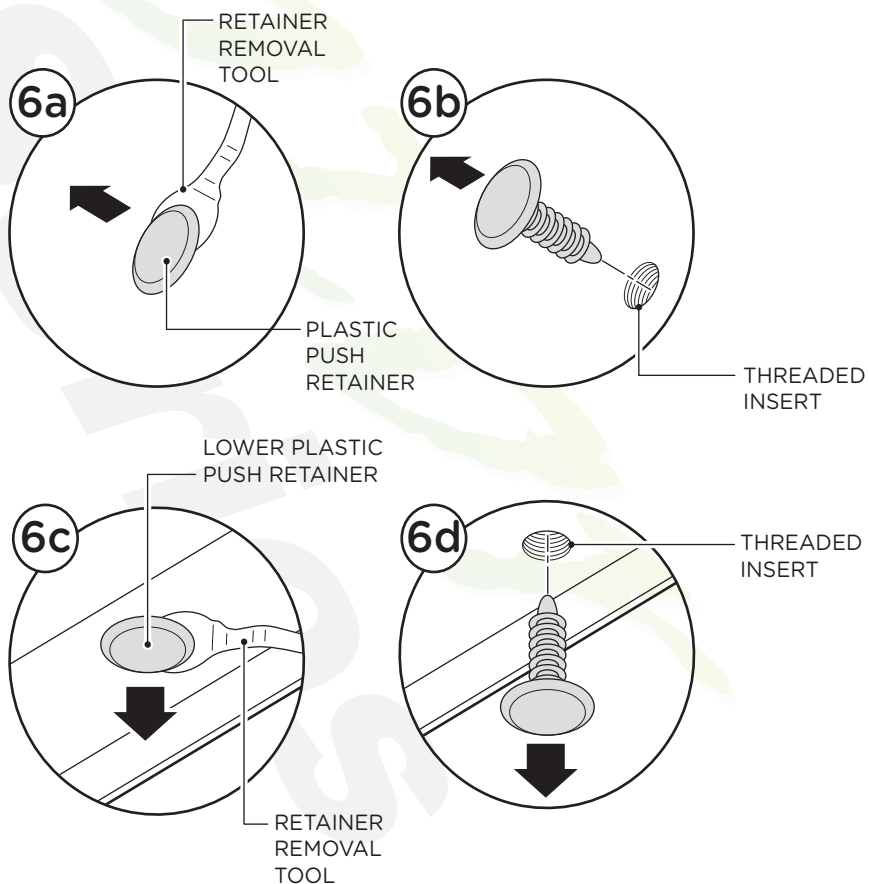

7. Fasten the top mounting point of each bracket to the rocker panel using one (1) M8 x 30 mm Hex Head Bolt, one (1) M8 Flat Washer and one (1) M8 Lock Washer (7a).

Complete installation of brackets by fastening the lower mounting point of each bracket to the pinch weld using one (1) M8 x 30 mm Hex Head Bolt, one (1) M8 Flat Washer and one (1) M8 Lock Washer (7b).

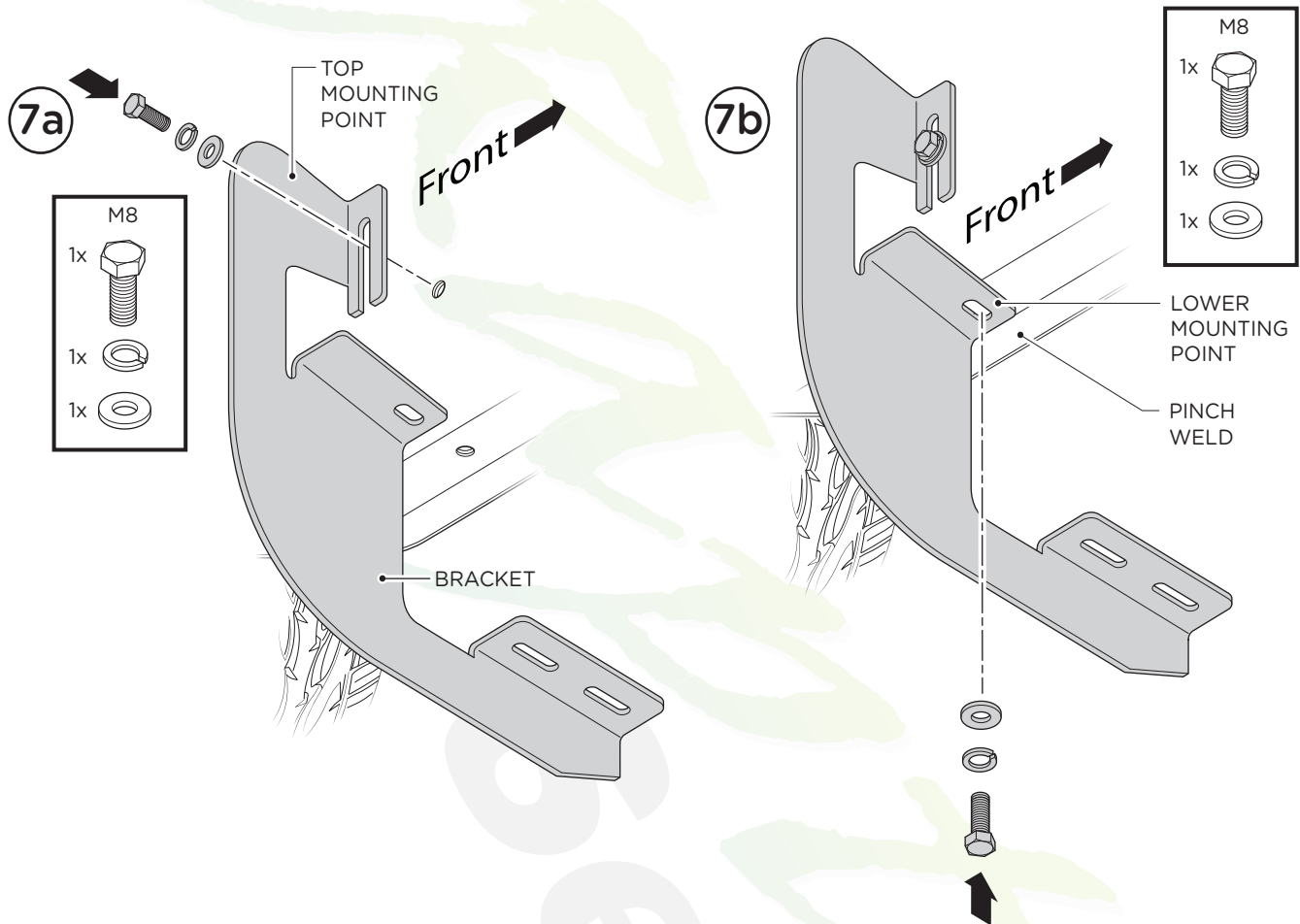

6" OEM RUNNING BOARD

1. Place Running Board on brackets. Each running board is marked Driver and Passenger.

2. Slide M8 threaded studs in track system on the bottom of the Running Board to line up to mounting holes in each bracket.

3. Fasten Running Board on each bracket by using two (2) M8 Flat Washers, two (2) M8 Lock Washers and two (2) M8 Hex Head Nuts per bracket.

When all hardware is in place, everything must be tightened. Tighten until the split lock washer is flat between the M8 Flat Washer and M8 Hex Head Nut.

Repeat these steps for driver side installation.

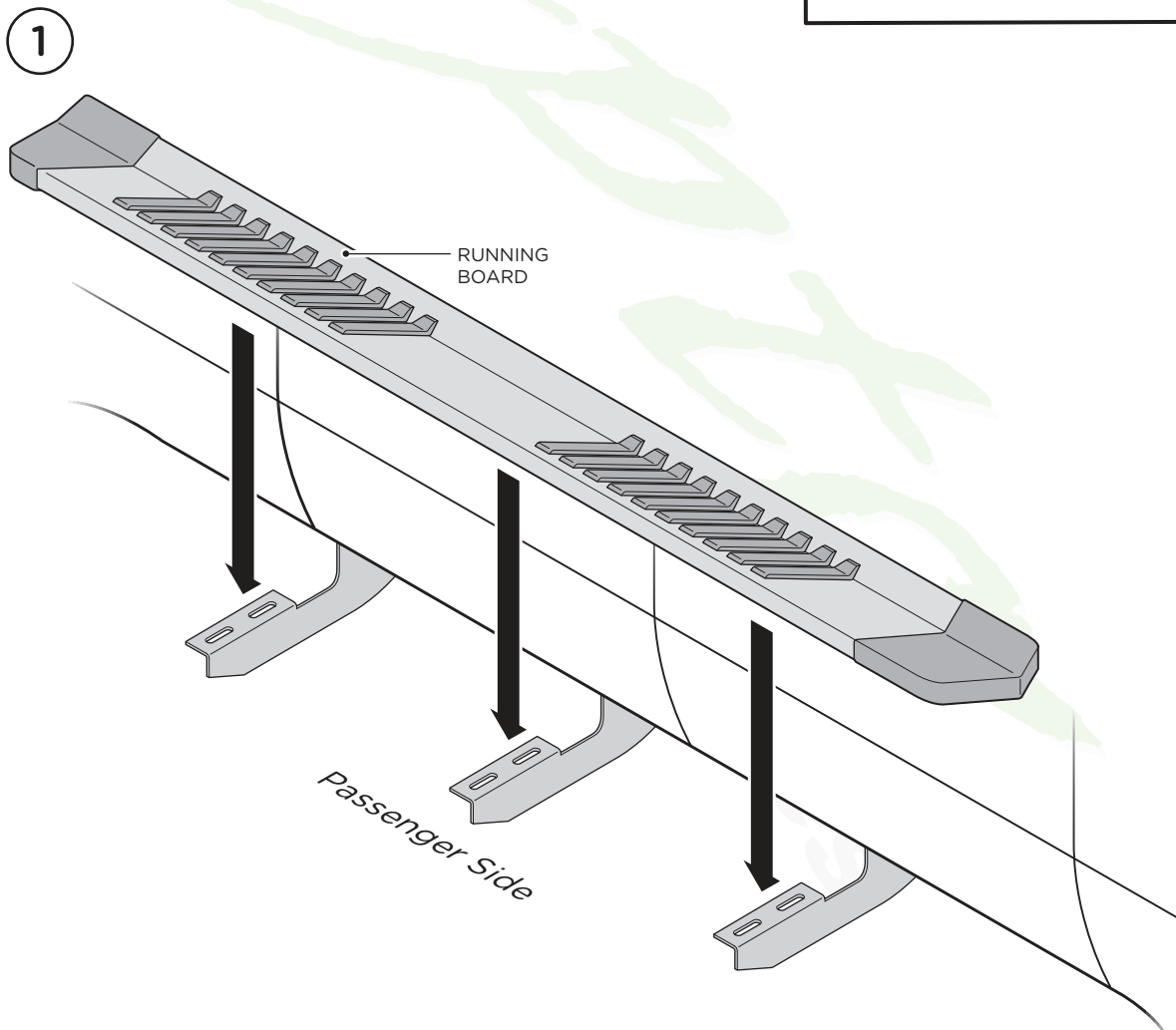
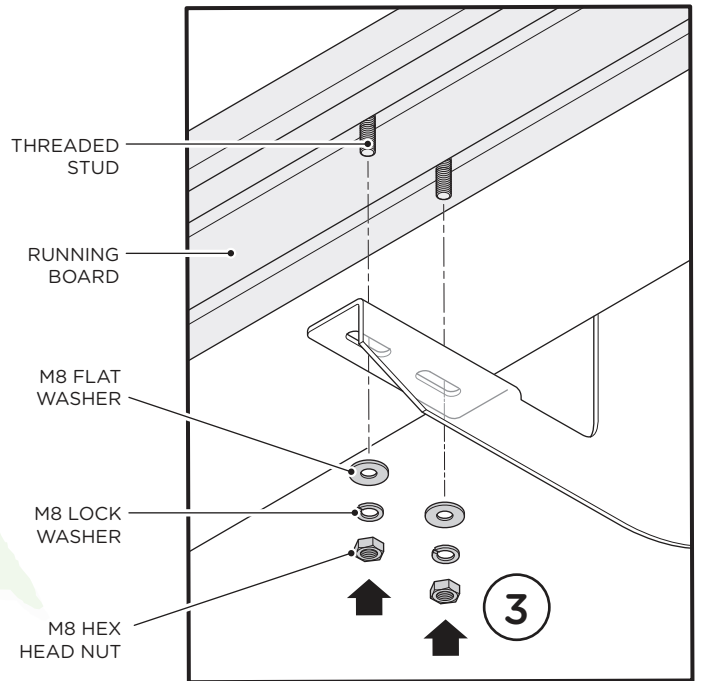

1701-0052, 1701-0052BT