



INSTALLATION INSTRUCTION

89300

Rev A

Rancho 2" – 2½" Leveling Kit

READ ALL INSTRUCTIONS THOROUGHLY FROM START TO FINISH BEFORE BEGINNING INSTALLATION



P/N	DESCRIPTION	QTY
RS66300R5:	1999-2007 CHEVY 1500	
RS5371	RS5000 Shock	2
RS176682	Torsion Arm	2
RS89300	Instruction	1



P/N	DESCRIPTION	QTY
RS66350R5:	2001-2010 CHEVY 2500	
RS5370	RS5000 Shock	2
RS176683	Torsion Arm	2
RS89300	Instruction	1



P/N	DESCRIPTION	QTY
RS66351R5:	2011-2013 CHEVY 2500 HD	
RS5378	RS5000 Shock	2
RS176684	Torsion Arm	2
RS89300	Instruction	1

TORSION BAR ADJUSTING ARM INSTALLATION

- 1) Park the vehicle on a level surface. Set the parking brake and chock rear wheels. Measure and record the distance from the center of each wheel to the top of the fender opening. See illustration 1.

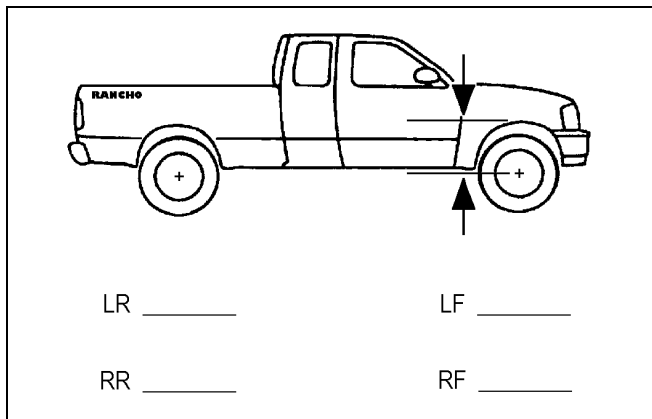

Illustration 1

- 2) Raise the front of the vehicle and support the frame with jackstands. Remove the front wheels and set them aside.

- 3) Mark and measure the exposed portion of threads of the torsion bar adjusting bolt. Make alignment marks on the torsion bars, the lower control arms, and the adjustment arms. See illustration 2.

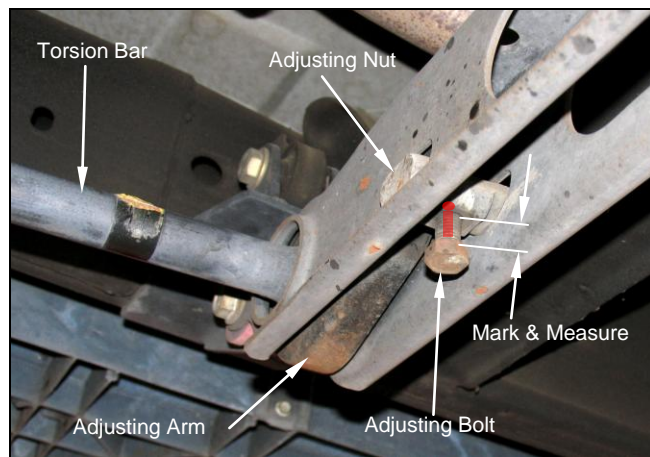

Illustration 2

- 4) Install the appropriate torsion bar unloading tool. Make sure top of tool is seated in hole in the top of the crossmember, and the tip of the tools bolt is seated in divot of OE adjusting arm. Slowly increase the tension on the torsion bar until adjusting nut is loose in crossmember. See illustration 3.

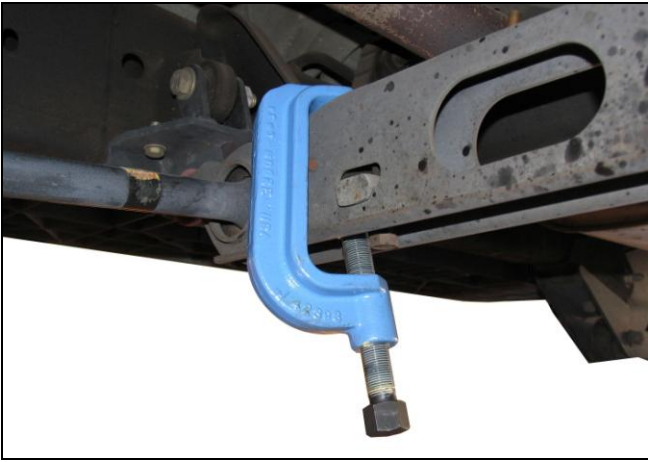

Illustration 3

- 5) Slide adjusting nut out of slot and remove the adjusting nut along with bolt. Relieve the tension on the torsion bar and remove the tool. See illustration 4.

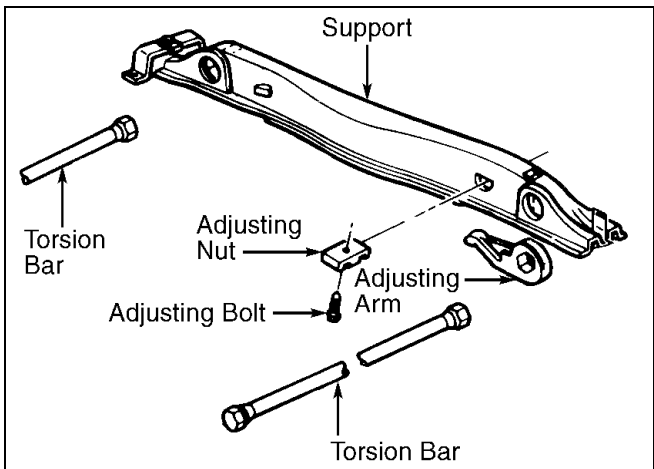

Illustration 4

- 6) Carefully slide the torsion bar forward and remove the adjustment arm. **CAUTION!!!** Do not nick the CV boot with the torsion bar.
- 7) Remove OE torsion bar adjusting arm from crossmember.
- 8) Hold the new Rancho adjusting arm in the crossmember in the same location as removed OE adjusting arm. Slide the torsion bar back into the cross member until it seats properly into the new adjusting arm.
- 9) Using the torsion bar unloading tool, adjust the new torsion bar key up high enough so that the adjusting nut and bolt can be re-installed.
- 10) Slide adjusting nut and bolt into slot in crossmember. Slowly relieve the tension on the torsion bar, making sure tip of adjusting bolt is seated in divot of adjustment arm. Remove the tool.

SHOCK INSTALLATION

- 11) Remove upper shock mounting nut or nuts, and any washer and bushing. See illustration 5.
- 12) Remove lower shock mounting nut and bolt.
- 13) Remove shock and any remaining upper washer and bushing.
- 14) If applicable, Install supplied boot and upper shock washer and bushing onto new Rancho shock absorber.
- 15) Slide upper shock mounting stud(s) through upper shock mount. Install any upper shock bushings, washers, and nuts. Tighten to factory torque specifications.
- 16) Install lower shock mounting bolt and nut. Tighten to factory torque specifications.

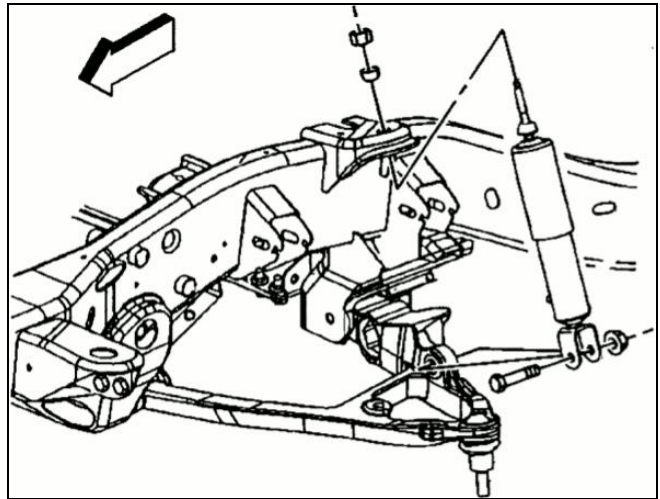

Illustration 5

- 17) Install front wheels and lower vehicle to ground. Tighten the lug nuts factory torque specifications.

FINAL ADJUSTMENTS

- 18) Drive vehicle at least 100 feet to settle front suspension.
- 19) Measure and record the distance from the center of each wheel to the top of the fender opening. See illustration 1.
- 20) Adjust torsion bar adjusting bolt to desired ride height. When adjusting ride height, one turn of the adjusting bolt will change ride height by $\frac{1}{4}$ ". Vehicle load, worn or overloaded components may yield different results.
- 21) Readjust headlamps
- 22) Have vehicle aligned to factory specifications.