



## **INSTALLATION INSTRUCTIONS**

**2015-up GMC 2500HD / 3500HD**

**PART # FBG151BLR / BTG151BLR / FSG151BL1  
BSG151BL1 / FBG155BLR / BTG155BLR**

NOTE: YOU WILL HAVE TO CUT OFF A PORTION OF THE INNER FENDER WELL.

1. Open the hood and remove the plastic radiator cover. There will be (12) plastic clips.
2. Remove the (4) 10mm bolts holding the top of the grille in place.
3. Remove two 7mm screw from each fender well. You may have to unsnap the first two clips of the fender flare. Remove the painted plastic bumper.
4. Remove the factory side brackets. There will be (3) 15mm bolts on each side.
5. Remove the (4) 10mm bolts from the lower grille. Remove grille.
6. Unplug sensor and fog light wiring harness.
7. Remove the factory bumper by removing the two 18mm bolts from each side of the frame. They will be facing downward.
8. Reinstall the factory grille and plastic radiator cover.
9. Remove the two black bumper mounting plate by removing the (4) 15mm bolts. The bolts will be used to install the Ranch Hand Frontend.
10. Remove the side and bottom tow hook bolts. Mount the support brackets to the outer side of the frame rails. Reinstall factory bolts.
11. Install splash guard by removing (1) 10 mm bolt (see drawing for location). Place a 5/16" flat washer between the truck body and the splash guard. Reinstall factory bolt and use 5/16" bolt in the other hole.
12. For Legend frontends remove the outer sensor brackets from factory bumper. Install them into the bottom insert of the frontend.
13. If fog lights are present, mount them to the fog light brackets provided and then to the frontend. Follow instructions in LBG151BP to install.
14. Mount the frontend to the frame by reusing the 15mm factory bolts. Level the frontend and then tighten bolts. Use the 1/2" bolts to mount the frontend to the support brackets.
15. Mount the license plate using 1/4" bolts to the bottom grille insert.
16. Hook up the sensor and fog light wires. You can run them through the square opening in the mounting brackets just below the top plate. Adjust the lights and sensors if needed.

***MAKE SURE ALL NUTS AND BOLTS ARE TIGHT!***

**----- WARNING -----**

Special care should be exercised in the handling, storage and installation of Kaspar Ranch Hand equipment.

The actual weight of each piece of equipment will vary depending on style and model. The weight of the equipment is sufficient in volume to warrant special care, assistance and in some instances, the use of mechanical equipment during the transfer and installation of the equipment.

Do not assume a position directly under the equipment during installation. Be sure the equipment has been connected and stabilized during installation to prevent falling or shifting of positions.

Periodically check tightness of bolts to make sure they are tight, and unlikely to fail.

# FBG151BLR

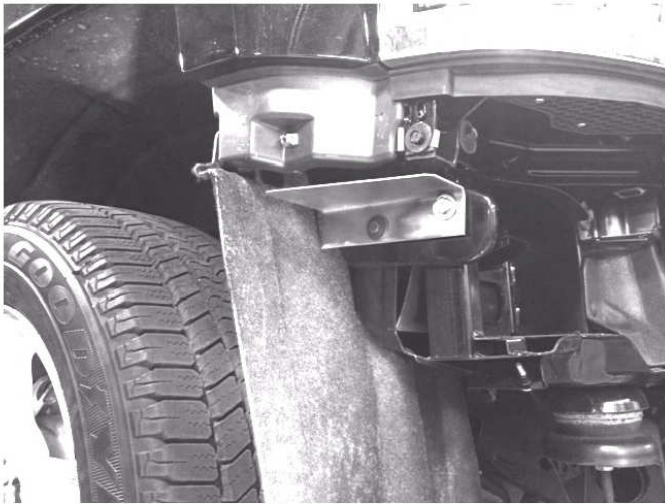

ITEM NO.	PART NUMBER	DESCRIPTION	QTY.
1	FBC151SGBL	SPLASH GUARD	1
2	FBG151SBDBL	SUPPORT BRACKET DRIVER	1
3	FBG151SBPBL	SUPPORT BRACKET PASSENGER	1
4	G3227-016000	RUBBER GROMMET	4
5	B0-136	HEX HEAD BOLT 5/16" - 18 X 1"	1
6	BH-166	FLAT WASHER 5/16"	4
7	BN-17	HEX NUT 5/16" - 18	1
8	BO-506	HEX HEAD BOLT 1/2" - 13 X 2"	2
9	BH-154	FLAT WASHER 1/2"	4
10	BN-36	KEP NUT 1/4" - 20	4
11	BN-155	LOCK NUT 1/2" - 13	2
12	BO-459	HEX HEAD BOLT 1/4" 20 X 1"	4
13	BP-428	BUTTON PLUG	4

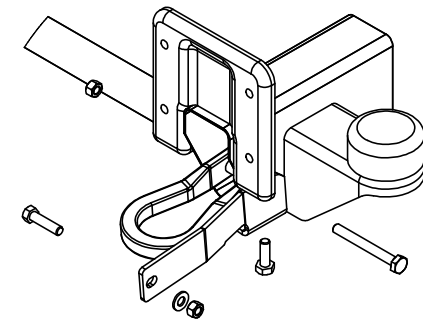
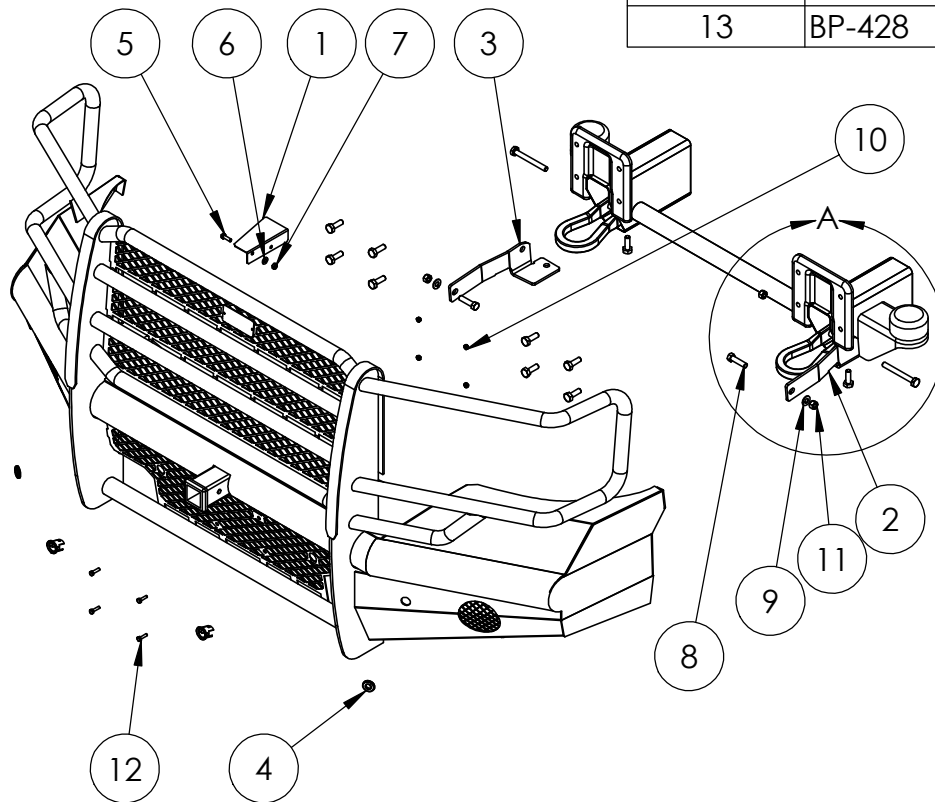

DETAIL A  
SCALE 1 : 10

Looking for dependable off-road bumpers?  
Rely on Ranch Hand for quality and long-lasting products.