



## **INSTALLATION INSTRUCTIONS**

### **2016–up CHEVY 1500 SUMMIT FRONT BUMPERS PART # FSC16HBL1 / BSC16HBL1**

1. Unhook the fog light wires if present.
2. Remove the factory side brackets. There will be three 15mm bolts on each side.
3. Open the hood and remove the plastic radiator cover. There will be several push clips.
4. Remove the factory grille by removing four bolt on top and four bolts from the bottom. Also, there will be 6 clips that hold the grille in place.
5. Remove the factory bumper by removing the two 18mm bolts from each side of the frame. They will be facing down.
6. Lay the bumper down then remove the sensor and fog light wires (if present) from the bumper.
7. Also, remove the sensor holders from the factory bumper. They will be reused in the replacement bumper.
8. Remove the two black bumper mounting plate by removing the three 15mm bolts. The bolts will be used to install the Ranch Hand Summit Frontend.
9. Remove the tow hook bolts if present. Tow hooks will be reinstalled.
10. Install the support brackets to the outer side of the frame and reinstall the tow hooks. The driver side will only use one bolt. Note: You may have to loosen the 21mm bolts of the 1" round bar that wraps around the body mount to install the support bracket.
11. Reinstall the factory grille and plastic radiator cover.
12. If fog lights are present, mount them to the fog light brackets provided and then to the Summit. Follow instructions in LBC16HBP to install.
13. Mount the Summit to the frame by reusing the 15mm factory bolts. Level the Summit and then tighten bolts. Use the ½" carriage bolts to mount the frontend to the support brackets.
14. Mount the license plate using ¼" bolts to the two slotted holes in the center of the Summit.
15. Hook up the sensor and fog light wires. You will need to use the pigtails for the outside sensors. You can run them through the rectangle opening in the uprights just below the top plate. Also, there are three small holes in the back of the top plate to zip tie the wire in place. Adjust the lights sensors if needed.
16. **MAKE SURE ALL NUTS AND BOLTS ARE TIGHT!**

### **-----WARNING-----**

Special care should be exercised in the handling, storage and installation of Kaspar Ranch Hand equipment. The actual weight of each piece of equipment will vary depending on style and model. The weight of the equipment is sufficient in volume to warrant special care, assistance and in some instances, the use of mechanical equipment during the transfer and installation of the equipment.

Do not assume a position directly under the equipment during installation. Be sure the equipment has been connected and stabilized during installation to prevent falling or shifting positions. Periodically check tightness of bolts to make sure they are tight, and unlikely to fail.

# FSC16HBP

FSC14HSBDBL				1
FSC14HSBDBL				1
Pigtail				2
Hex Head Bolt	1/2" - 13 x 1 1/2"		Grade 5	3
Blk.Carriage Bolt	1/2" - 13 x 1 1/2"		Grade 5	2
Flat Washer	1/2"			8
Lock Washer	1/2"			5
Hex Nut	1/2" - 13			5
Hex Head Bolt	1/4" - 20 x 1"			4
KeP Nut	1/4" - 20			2
Button Plug	Button Plug		BPFE-25MM	4

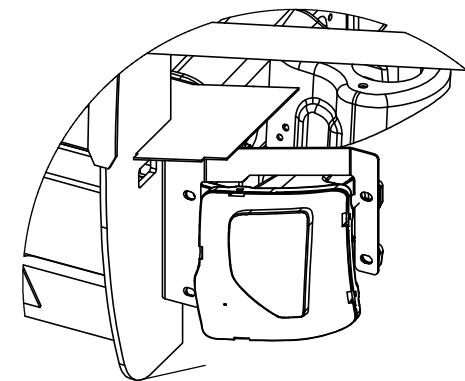
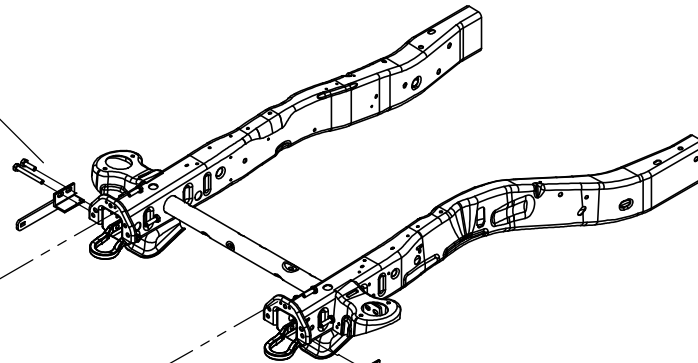
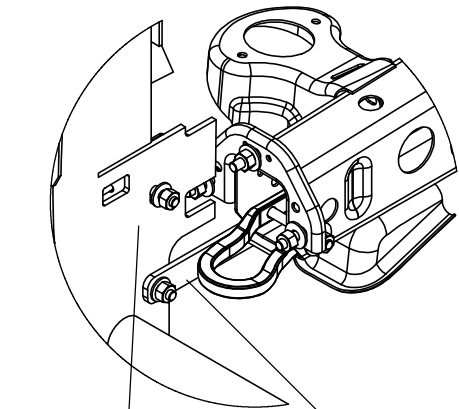

DETAIL C  
SCALE 1:3

DETAIL A  
SCALE 1:3



STANDARDS - UNLESS OTHERWISE NOTED			
THE FOLLOWING TOLERANCES APPLY			
DIMENSION	TO	MACHINED	WELDED
Ø.01	Ø.12	+0.001	+0.001
Ø.12	Ø.75	+0.002	+0.002
Ø.75	Ø.200	+0.003	+0.003
Ø.200	Ø.500	+0.004	+0.004
Ø.500	Ø.100	+0.005	+0.005
Ø.100	Ø.250	+0.006	+0.006
Ø.250	Ø.500	+0.007	+0.007
Ø.500	Ø.100	+0.008	+0.008
Ø.100	Ø.250	+0.009	+0.009
Ø.250	Ø.500	+0.010	+0.010
Ø.500	Ø.100	+0.011	+0.011
Ø.100	Ø.250	+0.012	+0.012
Ø.250	Ø.500	+0.013	+0.013
Ø.500	Ø.100	+0.014	+0.014
Ø.100	Ø.250	+0.015	+0.015
Ø.250	Ø.500	+0.016	+0.016
Ø.500	Ø.100	+0.017	+0.017
Ø.100	Ø.250	+0.018	+0.018
Ø.250	Ø.500	+0.019	+0.019
Ø.500	Ø.100	+0.020	+0.020
Ø.100	Ø.250	+0.021	+0.021
Ø.250	Ø.500	+0.022	+0.022
Ø.500	Ø.100	+0.023	+0.023
Ø.100	Ø.250	+0.024	+0.024
Ø.250	Ø.500	+0.025	+0.025
Ø.500	Ø.100	+0.026	+0.026
Ø.100	Ø.250	+0.027	+0.027
Ø.250	Ø.500	+0.028	+0.028
Ø.500	Ø.100	+0.029	+0.029
Ø.100	Ø.250	+0.030	+0.030
Ø.250	Ø.500	+0.031	+0.031
Ø.500	Ø.100	+0.032	+0.032
Ø.100	Ø.250	+0.033	+0.033
Ø.250	Ø.500	+0.034	+0.034
Ø.500	Ø.100	+0.035	+0.035
Ø.100	Ø.250	+0.036	+0.036
Ø.250	Ø.500	+0.037	+0.037
Ø.500	Ø.100	+0.038	+0.038
Ø.100	Ø.250	+0.039	+0.039
Ø.250	Ø.500	+0.040	+0.040
Ø.500	Ø.100	+0.041	+0.041
Ø.100	Ø.250	+0.042	+0.042
Ø.250	Ø.500	+0.043	+0.043
Ø.500	Ø.100	+0.044	+0.044
Ø.100	Ø.250	+0.045	+0.045
Ø.250	Ø.500	+0.046	+0.046
Ø.500	Ø.100	+0.047	+0.047
Ø.100	Ø.250	+0.048	+0.048
Ø.250	Ø.500	+0.049	+0.049
Ø.500	Ø.100	+0.050	+0.050

MATERIAL:	See BOM
COATING:	
PROPRIETARY AND CONFIDENTIAL:	

NAME:	J. Stemm	DATE:	4/15/2016
CREATED BY:	J. Stemm	DATE:	4/15/2016
CHECKED BY:		DATE:	
APPROVED BY:		DATE:	
STATUS:		DATE:	

TITLE:		2016 CHEVY 1500 SUMMIT FRONT BUMPER	
SIZE:	DWG. NO:	FSC16HBP	REV:
D			
SCALE:	1:24	DO NOT SCALE DRAWING	SHEET 1 OF 1

## **INSTALLATION INSTRUCTIONS**

### **2016–up CHEVY 1500 SUMMIT FRONT BUMPERS PART # FSC16HBL1 / BSC16HBL1**

1. Unhook the fog light wires if present.
2. Remove the factory side brackets. There will be three 15mm bolts on each side.
3. Open the hood and remove the plastic radiator cover. There will be several push clips.
4. Remove the factory grille by removing four bolt on top and four bolts from the bottom. Also, there will be 6 clips that hold the grille in place.
5. Remove the factory bumper by removing the two 18mm bolts from each side of the frame. They will be facing down.
6. Lay the bumper down then remove the sensor and fog light wires (if present) from the bumper.
7. Also, remove the sensor holders from the factory bumper. They will be reused in the replacement bumper.
8. Remove the two black bumper mounting plate by removing the three 15mm bolts. The bolts will be used to install the Ranch Hand Summit Frontend.
9. Remove the tow hook bolts if present. Tow hooks will be reinstalled.
10. Install the support brackets to the outer side of the frame and reinstall the tow hooks. The driver side will only use one bolt. Note: You may have to loosen the 21mm bolts of the 1" round bar that wraps around the body mount to install the support bracket.
11. Reinstall the factory grille and plastic radiator cover.
12. If fog lights are present, mount them to the fog light brackets provided and then to the Summit. Follow instructions in LBC16HBP to install.
13. Mount the Summit to the frame by reusing the 15mm factory bolts. Level the Summit and then tighten bolts. Use the ½" carriage bolts to mount the frontend to the support brackets.
14. Mount the license plate using ¼" bolts to the two slotted holes in the center of the Summit.
15. Hook up the sensor and fog light wires. You will need to use the provided wire, butt connectors and split loom for the outside sensors. Cut the wire and split loom in have and use half for each side. You can run them through the rectangle opening in the uprights just below the top plate. Also, there are three small holes in the back of the top plate to zip tie the wire in place. Adjust the lights sensors if needed.
16. ***MAKE SURE ALL NUTS AND BOLTS ARE TIGHT!***

#### **-----WARNING-----**

Special care should be exercised in the handling, storage and installation of Kaspar Ranch Hand equipment. The actual weight of each piece of equipment will vary depending on style and model. The weight of the equipment is sufficient in volume to warrant special care, assistance and in some instances, the use of mechanical equipment during the transfer and installation of the equipment. Do not assume a position directly under the equipment during installation. Be sure the equipment has been connected and stabilized during installation to prevent falling or shifting of positions. Periodically check tightness of bolts to make sure they are tight, and unlikely to fail.

8 7 6 5 4 3 2 1

### FSC16HABP

FSC14HSDBDL			1
FSC14HSDBDL			1
Split Loom	1/4" Black Split Loom		4ft.
18/3 Gauge Wire			4ft.
Red Butt Connectors	22-18 AWG Connector		12
Hex Head Bolt	1/2" - 13 x 1 1/2"	Grade 5	3
Blk.Carriage Bolt	1/2" - 13 x 1 1/2"	Grade 5	2
Flat Washer	1/2"		8
Lock Washer	1/2"		5
Hex Nut	1/2" - 13		5
Hex Head Bolt	1/4" - 20 x 1"		4
Kep Nut	1/4" - 20		2
Button Plug	Button Plug	BPFE-25MM	4

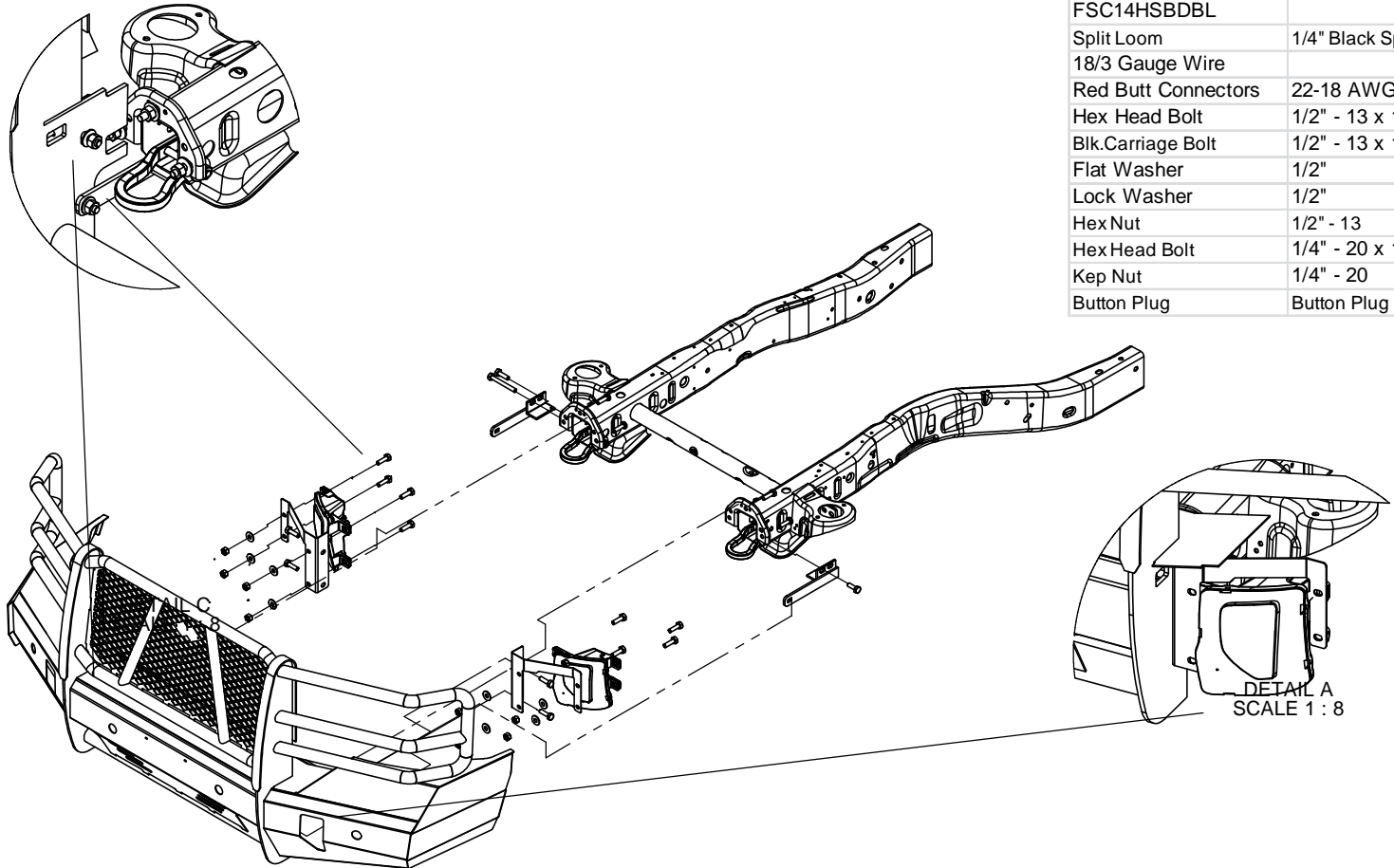

#### STANDARDS - UNLESS OTHERWISE NOTED

THE FOLLOWING TOLERANCES APPLY			
DIMENSION		MACHINED	WELDED
OVER	TO		
0.0	1.5	±.008	±.031
1.5	7.0	±.010	±.031
7.0	20.0	±.020	±.063
20.0	50.0	±.030	±.125
50.0	120.0	±.060	±.188
120.0	240.0	±.080	±.250
ANGLES		±0.1°	±.50°

**MATERIAL:**  
See BOM

**COATING:**

**PROPRIETARY AND CONFIDENTIAL**  
THE INFORMATION CONTAINED IN THIS DRAWING IS THE SOLE PROPERTY OF KASPAR RANCH HAND. ANY REPRODUCTION IN PART OR AS A WHOLE WITHOUT THE WRITTEN PERMISSION OF KASPAR RANCH HAND IS PROHIBITED.

NAME	DATE
CREATED BY: J.STEMM	4/15/2016
CHECKED BY:	
APPROVED BY:	
STATUS:	



TITLE: <b>ASSEMBLY DRAWING, INSTRUCTONS</b>		
SUMMIT FRONT 2016 CHEVY HALF TON		
SIZE <b>B</b>	DWG. NO. <b>FSC16HABP</b>	REV <b>0A</b>
SCALE: 1:24	DO NOT SCALE DRAWING	SHEET 1 OF 1

8 7 6 5 4 3 2 1