



## **INSTALLATION INSTRUCTIONS**

### **2003-08 DODGE 1500 & 2003-2009 DODGE 2500/3500 PART # BBD030BLS / BBD030BLL / DBD030BLL**

\* **Bumpers will not fit** on `03 1500 series built prior 12/02. Look on the tag on the driver side door jam for date built \*

\* This installation requires lifting the rear of the bed to remove the factory receiver hitch \*

1. Unplug the license plate lights and trailer plug from the bumper. Remove the fasteners that hold the wire loom to the receiver hitch.
2. Long beds: Remove the back six bolts and leave the front two bolts tight.
3. Short beds: Remove the back four bolts and leave the front two bolts tight.
4. Remove the three 21mm bolts, on each side, that goes through the frame. Loosen the four 15mm bolts, on each side, for the side brackets on the bumper.
5. Raise the rear of the truck bed high enough to remove the factory bumper and receiver hitch.
6. When raising the rear of the truck bed, use caution so that the bed does not hit the rear of the cab.
7. When removing the rear bumper, lift the bumper up high enough over the alignment pins then pull the bumper out.
8. Lower the truck bed onto the frame. Reinstall the bed bolts and then tighten.
9. Slide the mounting brackets of the Ranch Hand bumper on the inner side of the frame.
10. On the 2500/3500 trucks, use three  $\frac{3}{4}$ " x 4  $\frac{1}{2}$ " bolts, on each side, to install. Tighten to 260 ft.lbs. Dry.
11. On the 1500 trucks, use two  $\frac{3}{4}$ " x 4  $\frac{1}{2}$ ", on each side. Then mount the angle iron brackets to the bumper brackets by using  $\frac{1}{2}$ " x 1  $\frac{1}{2}$ " bolts. Place the spacers inside the bottom of the frame and the place the  $\frac{1}{2}$ " x 1  $\frac{1}{2}$ " bolts through the frame and angle iron. Tighten  $\frac{1}{2}$ " nuts to 110 ft.lbs. Dry.
12. Level bumper and tighten all bolts.
13. ***MAKE SURE ALL NUTS AND BOLTS ARE TIGHT!***

## **WARNING**

Special care should be exercised in the handling, storage and installation of Kaspar Ranch Hand equipment.

The actual weight of each piece of equipment will vary depending on style and model. The weight of the equipment is sufficient in volume to warrant special care, assistance and in some instances, the use of mechanical equipment during the transfer and installation of the equipment. Do not assume a position directly under the equipment during installation. Be sure the equipment has been connected and stabilized during installation to prevent falling or shifting of positions.

Periodically check tightness of bolts to make sure they are tight, and unlikely to fail.

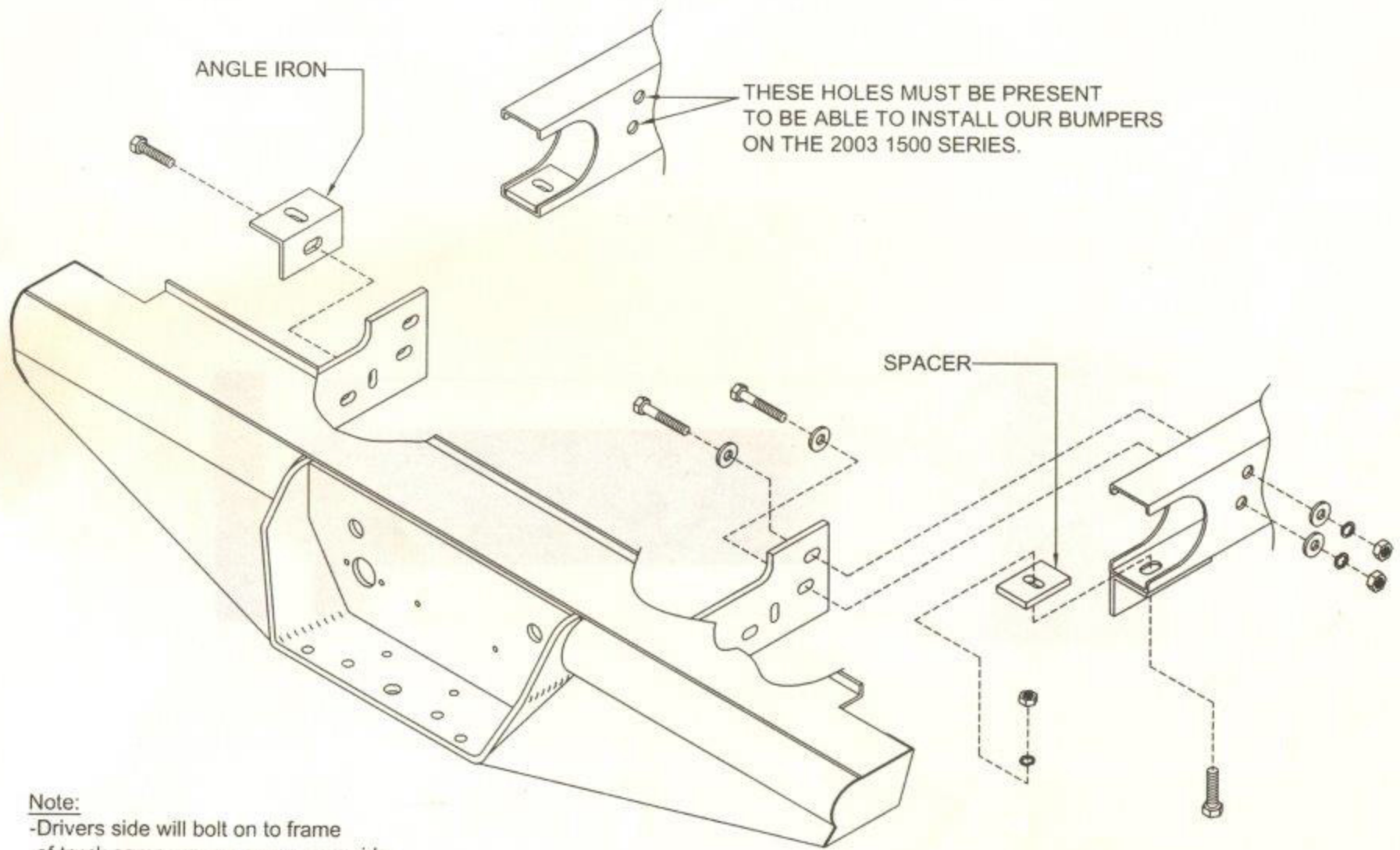

**Note:**

- Drivers side will bolt on to frame of truck same way as passenger side.
- The diagram shown will fit a BBD038BLS, BBD030BLS, BBD03BLL, DBD030BLL.

REVISIONS			
REV.	DESCRIPTION	DATE	APPROVED
1			

FILE NAME  
 CONTRACT NO.  
 DRAWN S.D.R.  
 CHECK  
 APPR  
 ISSUED 3-27-03

DWG NAME: MOUNTING INSTRUCTIONS FOR 03 DODGE 1500 BACK BUMPER  

**RANCH HAND**  
 TRUCK ACCESSORIES  
 PARTS REQUIRED: 1  
 DIMENSIONAL: FRACTIONAL 1/16  
 TOLERANCES: DECIMAL .005  
 BOM & NTS  
 SHEET

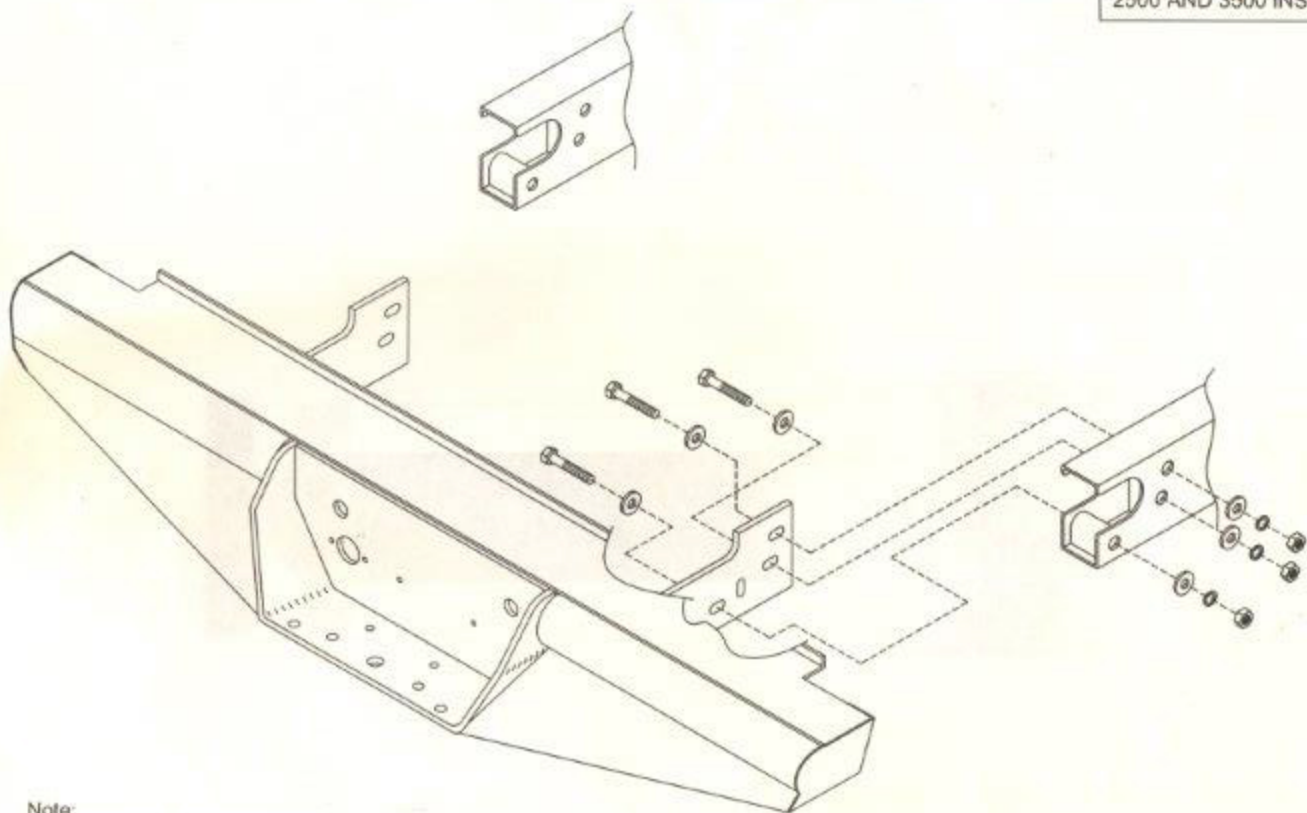
**Note:**

- Drivers side will bolt on to frame of truck same way as passenger side.
- Drivers side bolts are not shown for clarity.
- The diagram shown will fit a BBD038BLS, BBD030BLS, BBD038LL, DBD030BLL.

P/N: BBD03  
 REV: 3-27-03

P/N: BBD03  
 REV: 3-27-03



**RANCH HAND**  
 TRUCK ACCESSORIES

REVISIONS				REV	DESCRIPTION	DATE	APPROVED	DATE	REV	DESCRIPTION	DATE	APPROVED	DATE
1													

P/N: BBD03  
 REV: 3-27-03