

# Installation Instructions



## Trail Guard Front Bumper

For proper installation and best possible fit, please read all instructions BEFORE you begin.

### Important Safety Information



- CAUTION - Before driving, ensure that the bumper is properly secured to vehicle.
- Do not use automatic "brush-style" car washes.
- Do not use cleaning solvents of any kind.
- Periodically check all components for tightness.

### Contents

NOTE: Actual product may vary from illustration.

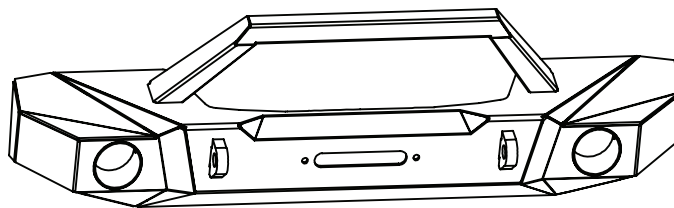

Trail Guard Bumper



Allen Wrench



Nut (4)

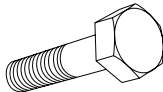

Bolt (4)



Washer (8)



Lock Washer (8)



Nut-Nylock (2)



Washer (4)



Stand Off (2)

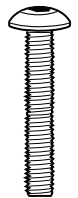

Bolt (2)

### Tools Required

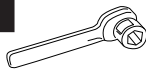

Socket Wrench



Marker

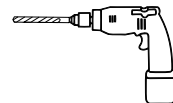

Drill

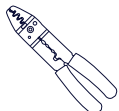

Crimps

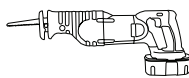

Powered Saw  
(or other cutting and trimming tool)

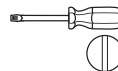

Flat head screwdriver  
or pry tool



Safety glasses

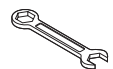

Wrench

### Before Installation Remove OE Bumper

Step 1 Remove the (6) push-pin screws to remove the plastic frame cover-plate.

Step 2 If equipped, disconnect the OE driving lights at the back of the light housings. Insulate ends and tie the wires to the frame. Do not cut ends.

Step 3 Using appropriate tools, remove the OE front bumper by removing the 8 hex nuts holding the bumper to frame mount flanges. Installation kit contains all new necessary attaching hardware for your Trail Guard JK Bumper.

Step 4 Remove and discard steel backing plates from inside frame rail.

Step 5 If you have fog lights remove phillips screws.

# Installation Steps

NOTE: Actual application may vary slightly from illustrations.

Remove the 6 plastic fasteners holding on the front lower air dam and remove. Earlier models you will need a Phillips head screwdriver. Later models can just be pulled out by hand.



1

Locate and remove the 8 nuts holding on the front bumper (on both sides) using an 18mm socket.

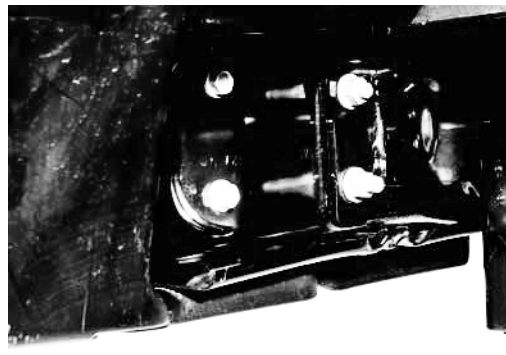

2

Carefully pull bumper away from frame to expose the fog light connections and wiring. Unplug fog lamps and remove wiring from bumper as necessary, remove bumper.



3

Remove the fog lamps using a Phillips head screwdriver, save lamps.

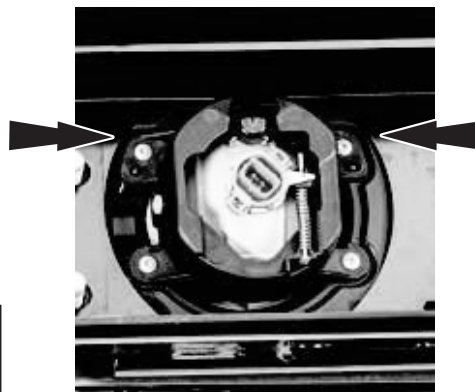

4

For 2012 and newer models some winches may require relocation of the vacuum pump. Remove hardware using a 10mm socket.



5

NOTE: FOR '07-'11 MODELS SKIP THESE STEPS go to Step 9

Remove 2 studs remaining hardware using a cut off wheel and drill hole to clear for remount.

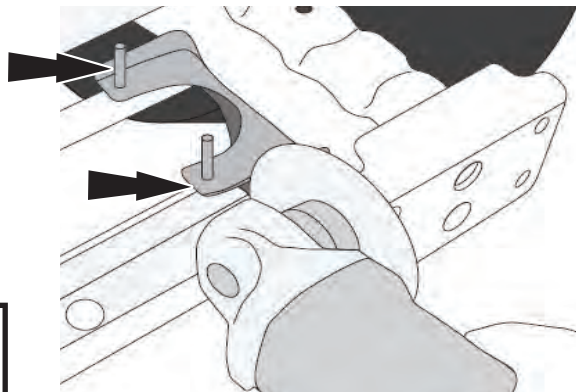

6

Re install vacuum pump using (2) stand offs and (2) bolts and (2) washers 2 Nuts. [spacer in the front is 3/4" and the rear is 1"]

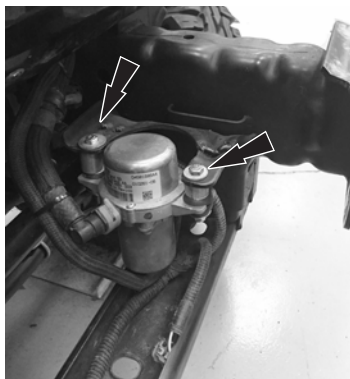

7

Mark the corner frame bracket then Cut trim as required on both left and right side to allow for larger winches to clear.

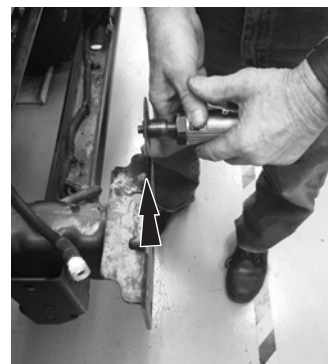

8

# Installation Steps

Mark the corner frame bracket on both sides to allow clearance for the larger Winch applications. NOTE: Exercise caution while trimming.



9

Place front bumper onto the frame lining up holes.

Caution: 2 person lift.

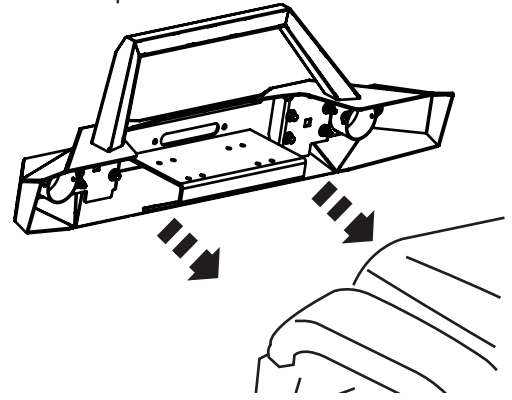

10

Driver Side Install (2) nuts and (2) bolts with (2) washers and (2) lock washers.

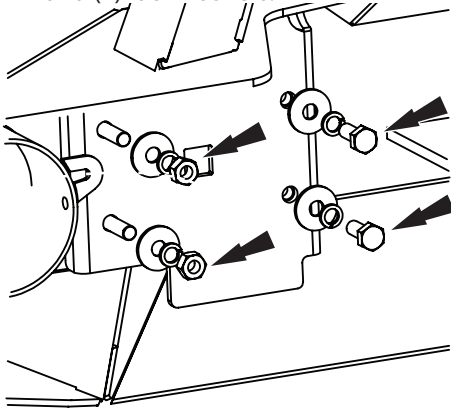

11

Passenger Side Install (2) nuts and (2) bolts with (2) washers and (2) lock washers.

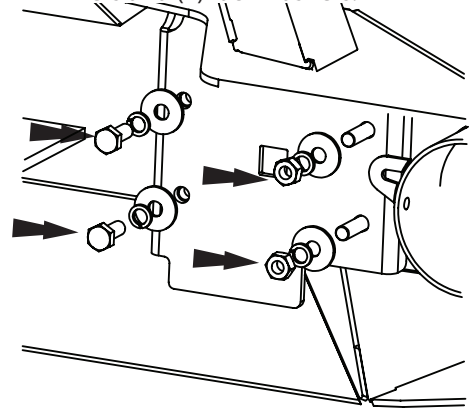

12

Re install the both fog lamps using a Phillips head screwdriver and hardware.

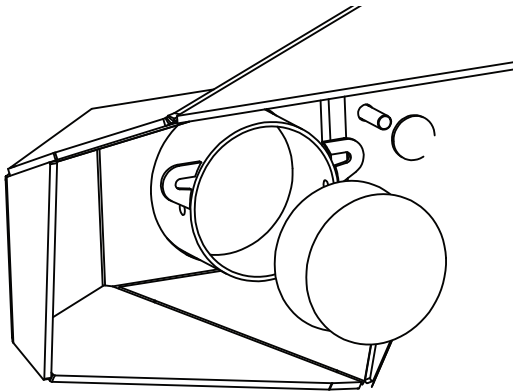

13

If you have purchased a winch install into existing hole. Follow your recommended winch install steps.

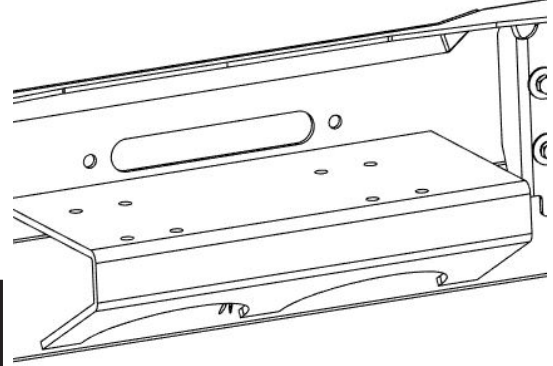

14

## Care and Cleaning

- Rampage Bumpers are built to last; any detergent you use to wash your vehicle is sufficient to clean the bumper. Do not use any harsh abrasive detergents.

## Congratulations!

You have purchased one of the many quality Rampage branded products offered by Lund International, Inc. We take the utmost pride in our products and want you to enjoy years of satisfaction from your investment. We have made every effort to ensure that your product is top quality in terms of fit, durability, finish and ease of installation.



Learn more about off-road bumpers we have.