

Installation Instructions

2007-2018 JK Wrangler
and JKU Wrangler Unlimited



Rock Rage Front Bumper

For proper installation and best possible fit, please read all instructions BEFORE you begin.

Important Safety Information



- CAUTION - Before driving, ensure that the bumper is properly secured to vehicle.
- Do not use automatic "brush-style" car washes.
- Do not use cleaning solvents of any kind.
- Periodically check all components for tightness.

Contents

NOTE: Actual product may vary from illustration.

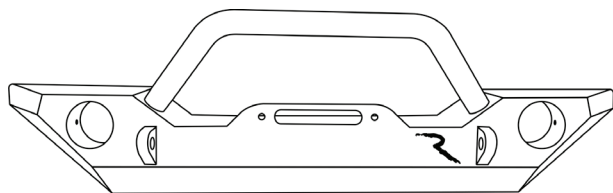

Rock Rage Bumper



4mm Nylock
Nut (4)



4mm Bolt (4)



4mm Washer
(8)



12mm Nylock
Nut (6)

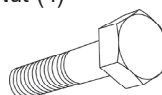

12mm Bolt (2)



12mm Washer
(8)



12mm Lock
Washer (8)

Tools Required



Socket Wrench

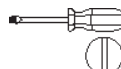

Flat head screwdriver
or pry tool



Safety glasses



Wrench

Before Installation Remove OE Bumper

Step 1: Remove the (6) push-pin screws to remove the plastic frame cover-plate.

Step 2: If equipped, disconnect the OE driving lights at the back of the light housings. Remove any fasteners holding the fog light wiring to the bumper. Insulate ends and tie the wires to the frame. Do not cut ends.

Step 3: Using appropriate tools, remove the OE front bumper by removing the 8 hex nuts holding the bumper to frame mount flanges. Installation kit contains all new attaching hardware necessary for installing your new Rock Rage JK Front Bumper.

Step 4: Remove and discard steel backing plates from inside frame rail.

Step 5: If you have fog lights remove phillips screws and set lights aside for reinstallation.

Installation Steps

NOTE: Actual application may vary slightly from illustrations.

Remove the 6 plastic fasteners holding on the front lower air dam and remove. Earlier models you will need a Phillips head screwdriver. Later models can just be pulled out by hand.



1

Locate and remove the 8 nuts holding on the front bumper (on both sides) using an 18mm socket.

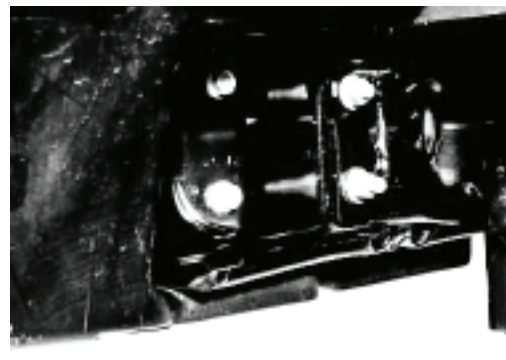

2

Installation Steps

Carefully pull factory bumper away from frame to expose the fog light connections and wiring. Unplug fog lamps and remove wiring from bumper as necessary, then remove bumper from the vehicle.

3



Remove the fog lamps from factory bumper using a Phillips head screwdriver, save lamps.

4

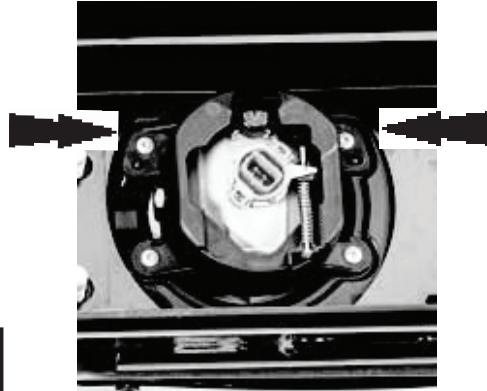

Install factory fog lamps (if equipped) in new bumper using provided 4mm hardware. If using aftermarket lights, use hardware provided with light.

5

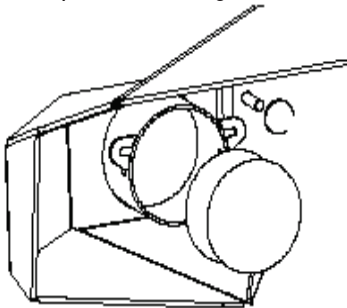

Place front bumper onto the frame, lining up built-in studs with factory frame holes.



Caution:
2 person lift

6

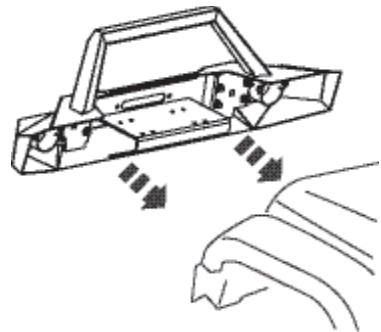

Mount bumper using provided 12mm hardware. Install requires (3) Nuts, (1) Bolt, (4) Flat Washers and (4) Lock Washers per side. Temporarily leave hand tight.

7

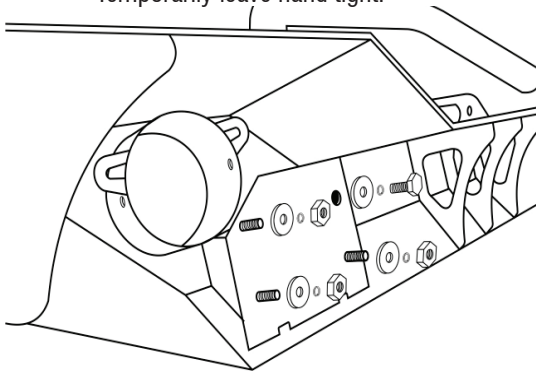

Center bumper left and right and level. Tighten hardware.

8

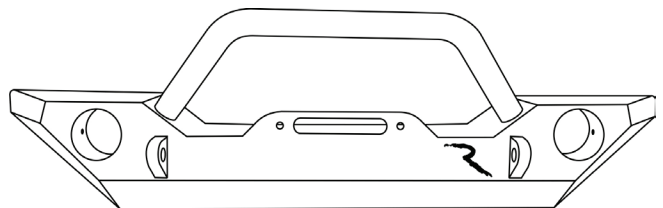

Care and Cleaning

- Rampage Bumpers are built to last; any detergent you use to wash your vehicle is sufficient to clean the bumper. Do not use any harsh abrasive detergents.

Congratulations!

You have purchased one of the many quality Rampage branded products offered by Lund International, Inc. We take the utmost pride in our products and want you to enjoy years of satisfaction from your investment. We have made every effort to ensure that your product is top quality in terms of fit, durability, finish and ease of installation.

