

Installation Instructions

07-18 Jeep Wrangler JK
18-19 Jeep Wrangler JL



JL/JK Tow Hitch

Important Safety Information



- Before driving, ensure that the Receiver Towing Hitch is properly secured to vehicle.
- Periodically check all components for tightness.

Contents

NOTE: Actual product may vary from illustration.

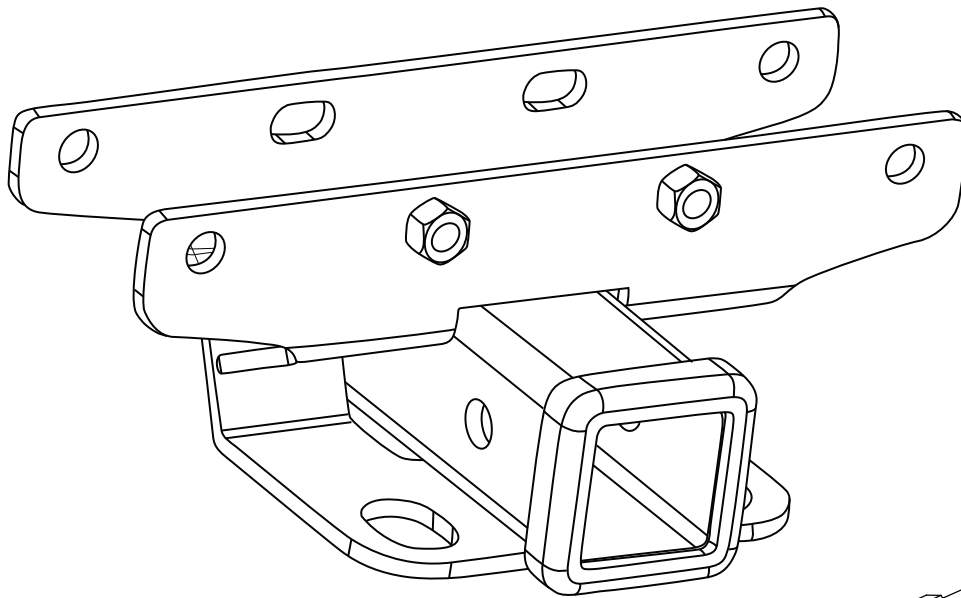

Tow Hitch

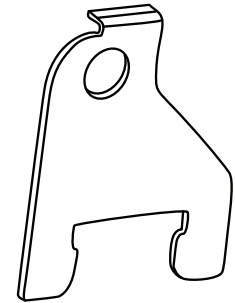

Trailer Wiring
Connector
Bracket

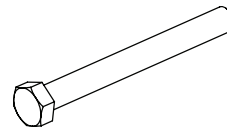

12-1.75mm x 120mm
Hex Bolt (4)

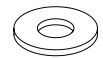

12mm x 32 mm x 3mm
Flat Washer (6)



12mm Lock
Washers (2)



12-1.75mm Nylock
Lock Nut (2)

NOTE: Trailer Wiring is NOT included in this kit

Required Tools

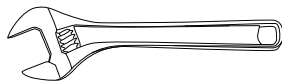

Wrench

OR



Ratchet and Socket
Set

Before Installation

REMOVE CONTENTS FROM BOX. VERIFY ALL PARTS ARE PRESENT.

READ INSTRUCTIONS CAREFULLY BEFORE STARTING INSTALLATION.

Installation Steps

NOTE: Actual application may vary slightly from illustrations.

1

Some JL Wranglers have an L-shaped support bracket connecting the rear bumper to the rear frame crossmember. From underneath the rear bumper determine if your vehicle has the L-shaped bracket by looking for the tabs to the rear bumper. **See Figure 1.** For instructions for installation with the L-Shaped bracket, please **Go To Page Page 3.** ⚠ Indicates start of installation steps with L-Shaped bracket.

For JL Wranglers without the L-shaped bracket and JK Wranglers, **Continue to Step 2.**

Figure 1

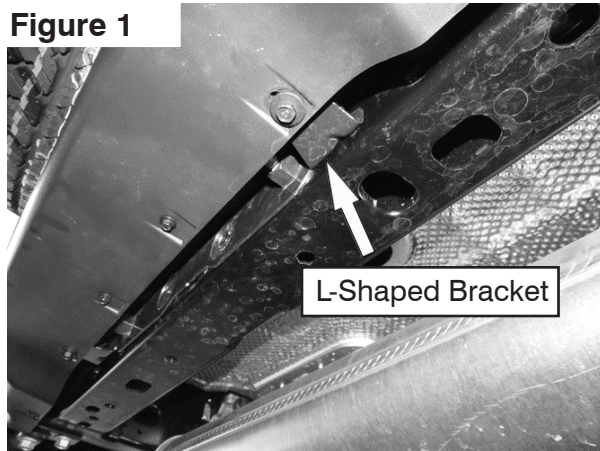

L-Shaped Bracket removed

2

Hold the Tow Hitch up to the frame and align the holes on the Hitch to the frame.

NOTE: The inner welded nuts on the Hitch will be to the rear of the vehicle.

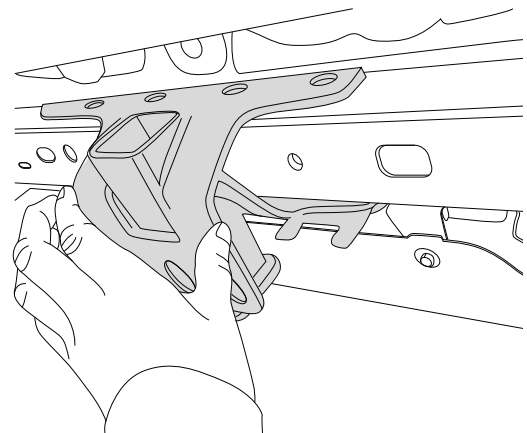

3

Insert provided (4) 12mm Hex Bolts, (4) 12mm Lock Washers and (4) 12mm Flat Washers in through the inner slots on the Hitch and through the frame crossmember. The center bolts thread into the welded nuts on the Hitch, the outer bolts receive (2) 12mm Flat Washers and (2) 12mm Nuts.

While installing the Left (driver) side bolt, install the Trailer Wiring Connector Bracket.

Snug but do not fully tighten hardware.

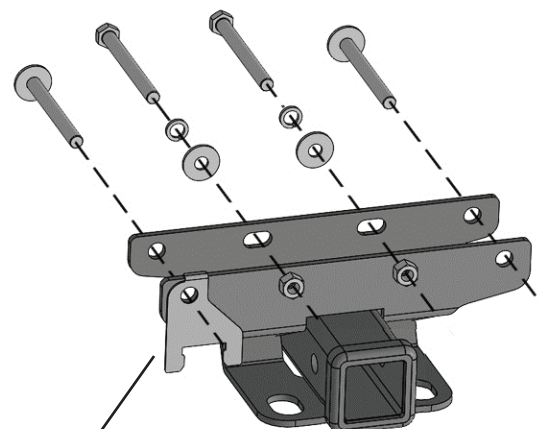

Trailer Wiring Plug Bracket

Installation Steps NOTE: Actual application may vary slightly from illustrations.

4 Check hitch is level and centered on the vehicle.

Tighten hardware.



! Installation Steps With L-Shaped Bracket

1 Remove two bolts securing L-Shaped bracket to the bumper.

Remove two bolts securing L-Shaped bracket to rear frame crossmember.

Save hardware and L-Shaped bracket for re-installation.

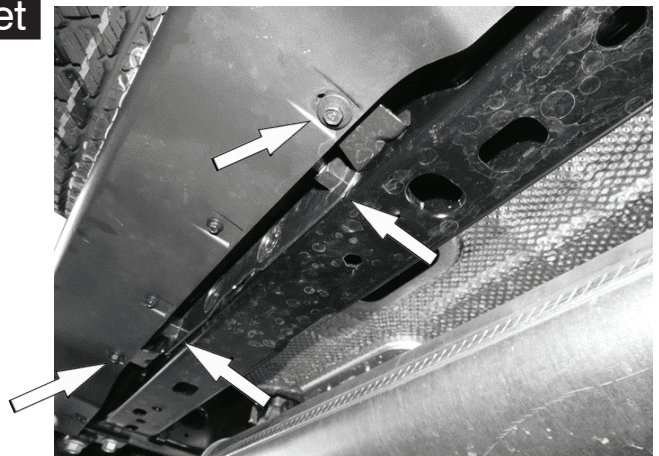

2 Loosen the (8) factory bumper bolts to help aid in L-shaped Bracket reinstallation.

There are two bolts on each side close to the frame and two bolts on each side near the end of the bumper at the tire.

Full removal of the rear bumper is not required in most cases.



3 Position the Tow Hitch in place on the rear crossmember, lining up the corresponding holes.

Insert provided (2) 12mm Hex Bolts, (2) 12mm Lock Washers and (2) 12mm Flat Washers in through the inner slots on the Hitch, through the frame and thread into the welded nuts on the Hitch.

Snug but do not fully tighten hardware.

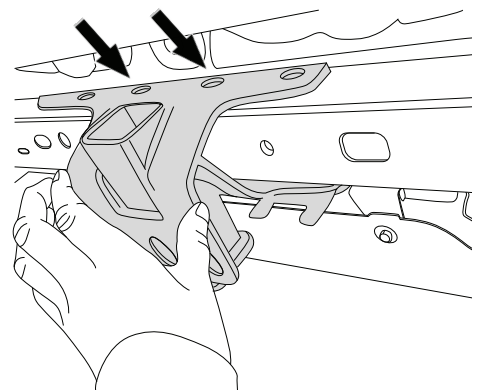

Installation Steps With L-Shaped Bracket

NOTE: Actual application may vary slightly from illustrations.

4

Re-install the L-Shaped bracket between the bumper and frame crossmember.

Position the L-Shaped bracket so that the large holes are over the welded nuts on the Tow Hitch.

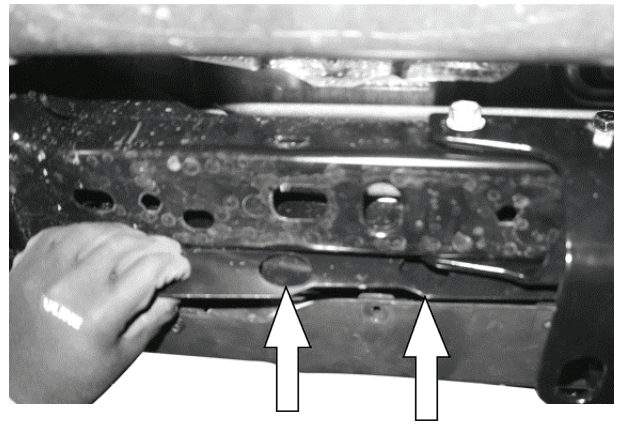

5

Re-install factory hardware at outer hole locations through the Tow Hitch, frame crossmember to the welded nuts on the L-Shaped bracket.

While installing the Left (driver) side bolt, install the Trailer Wiring Plug Bracket between the Tow Hitch and L-Shaped bracket.

Snug but do not tighten hardware.

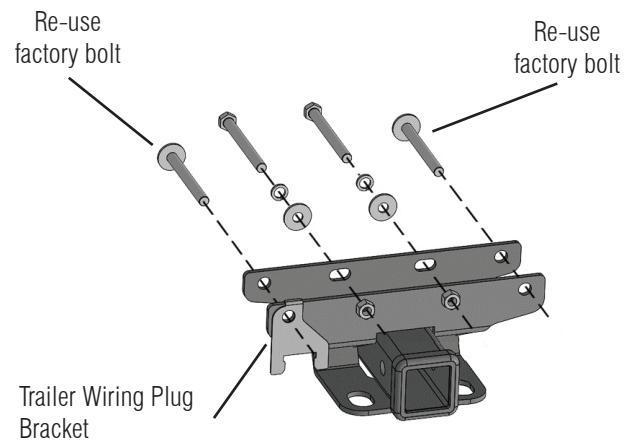

6

Check hitch is level and centered on the vehicle.

Tighten hardware.

Re-install hardware connecting L-Shaped bracket to bumper.
Tighten all bumper hardware.



Care and Cleaning

Regularly inspect the installation to make sure that all hardware is secure and tight. To protect your investment, wax this product after installing. Regular waxing is recommended to add a protective layer over the finish. Do not use any type of polish or wax that may contain abrasives that could damage the finish. Use mild soap to clean the Tow Hitch.

Congratulations!

You have purchased one of the many quality Rampage branded products offered by Lund International. We take the utmost pride in our products and want you to enjoy years of satisfaction from your investment. We have made every effort to ensure that your product is top quality in terms of fit, durability, finish and ease of installation.



The material that your product is made from can be recycled. Please also consider recycling the packaging that your product came in.



RAMPAGE
PRODUCTS

LUND
INTERNATIONAL

Learn more about trailer hitches and towing we have.