

Installation Instructions

18-19 Jeep Wrangler JL

I - Sheet Number I-26629 Rev.A



Rocker Guard

Care and Cleaning

- Wash only with mild soap and dry with a clean cloth.
- Every 3 months or 5000 miles check for loose hardware and tighten as necessary.

Congratulations!

You have purchased one of the many quality Rampage® branded products offered by Lund International. We take the utmost pride in our products and want you to enjoy years of satisfaction from your investment. We have made every effort to ensure that your product is top quality in terms of fit, durability, finish and ease of installation.

Recycle

The material that your product is made from can be recycled. Please also consider recycling the packaging that your product came in.

PARTS LIST:

1	Driver/Left Rocker Guard Assembly	4	8mm x 28mm OD x 3mm Flat Washers
1	Passenger/Right Rocker Guard Assembly	8	6-1.0mm x 30mm Hex Bolts
4	8-1.25mm x 35mm Hex Bolts	16	6mm x 22mm OD x 2mm Flat Washers
4	8mm Lock Washers	8	6mm Nylon Lock Nuts

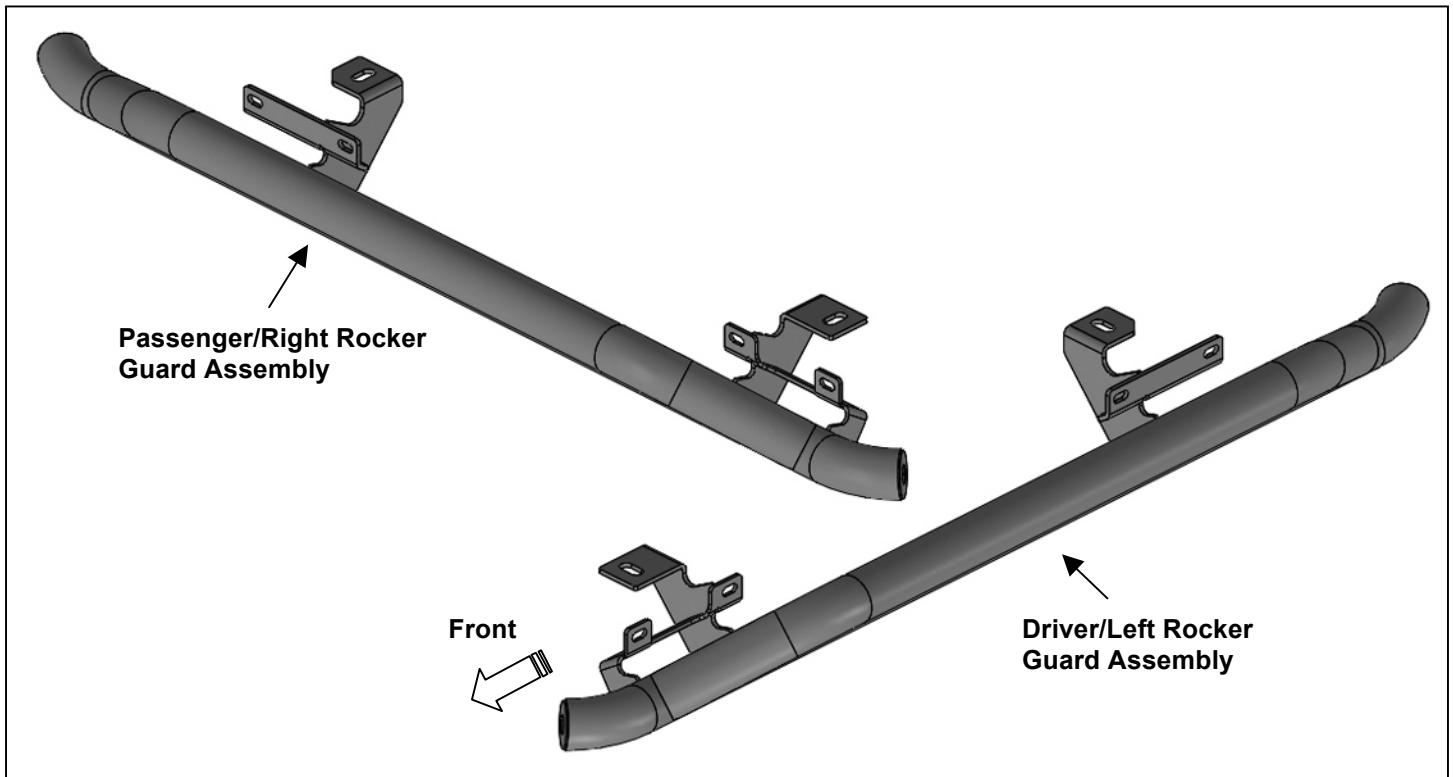

PROCEDURE:

- 1. REMOVE CONTENTS FROM BOX. VERIFY ALL PARTS ARE PRESENT. READ INSTRUCTIONS CAREFULLY. FACTORY INSTALLED OR AFTERMARKET "ROCK RAILS," SIDE STEPS OR RUNNING BOARDS MUST BE REMOVED. ASSISTANCE IS HIGHLY RECOMMENDED.**
- Start installation on the driver side of the vehicle. Locate the (2) pairs of holes in the pinch weld. Directly behind each pair of holes, locate the 8mm threaded hole in the floor of the vehicle, (**Figures 1 & 2**). **NOTE:** Threaded holes may be covered with undercoating. Scrape off excess undercoating to provide a flat surface for brackets.
- With assistance, attach the Rocker Guard to the **back** of the pinch weld using the included (4) 6mm x 25mm Hex Bolts, (8) 6mm Flat Washers and (4) 6mm Nylon Lock Nuts, (**Figures 3—6**). Leave hardware loose at this time.
- Attach the mounting tabs on the Rocker Guard to the (2) threaded holes in the floor with the included (2) 8mm x 35mm Hex Bolts, (2) 8mm Lock Washers and (2) 8mm Flat Washers, (**Figures 3—6**).
- Adjust the Rocker Guard and tighten all hardware.
- Repeat **Steps 2—5** for passenger/right side Rocker Guard installation.
- Do periodic inspections to the installation to make sure that all hardware is secure and tight.

To protect your investment, wax this product after installing. Regular waxing is recommended to add a protective layer over the finish. Do not use any type of polish or wax that may contain abrasives that could damage the finish. Mild soap may be used to clean the Rocker Guard.

Driver Side Installation Pictured

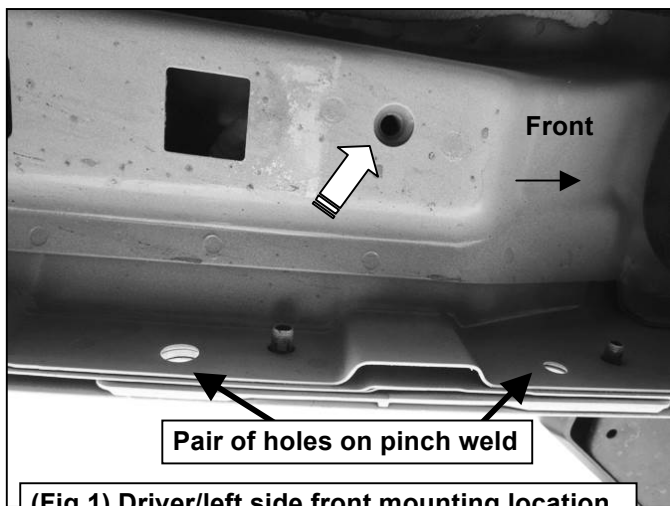

(Fig 1) Driver/left side front mounting location

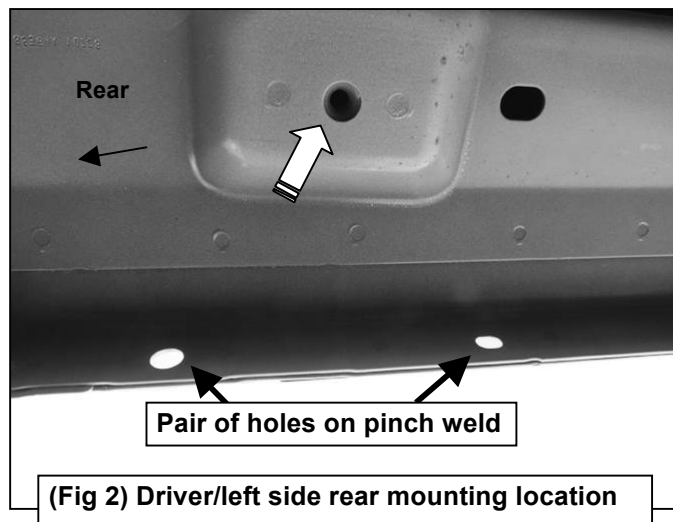

(Fig 2) Driver/left side rear mounting location

8mm Hex Bolt
8mm Lock Washer
8mm Flat Washer

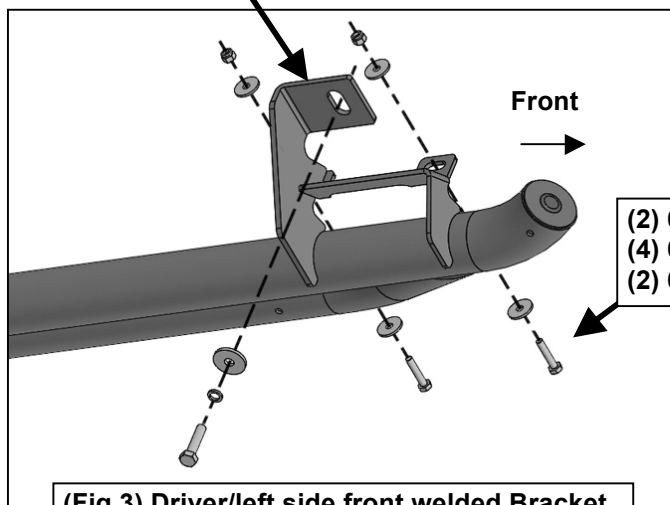

(2) 6mm x 25mm Hex Bolts
(4) 6mm Flat Washers
(2) 6mm Nylon Lock Nuts

(Fig 3) Driver/left side front welded Bracket attached to pinch weld and inner floor panel

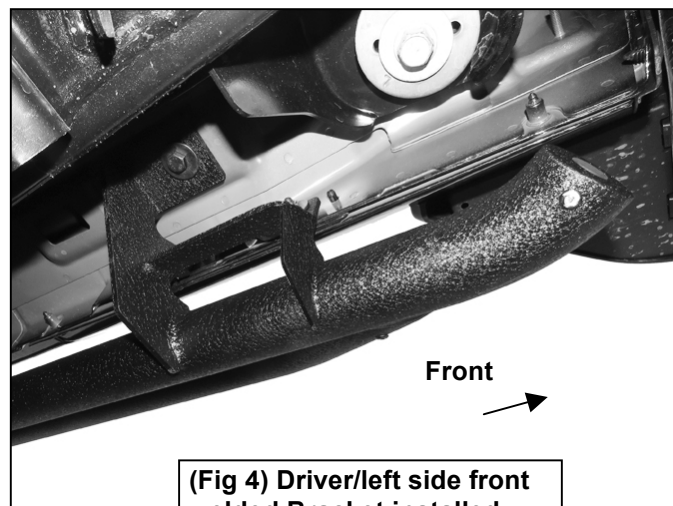

(Fig 4) Driver/left side front welded Bracket installed

Driver Side Installation Pictured

- 8mm Hex Bolt
- 8mm Lock Washer
- 8mm Flat Washer

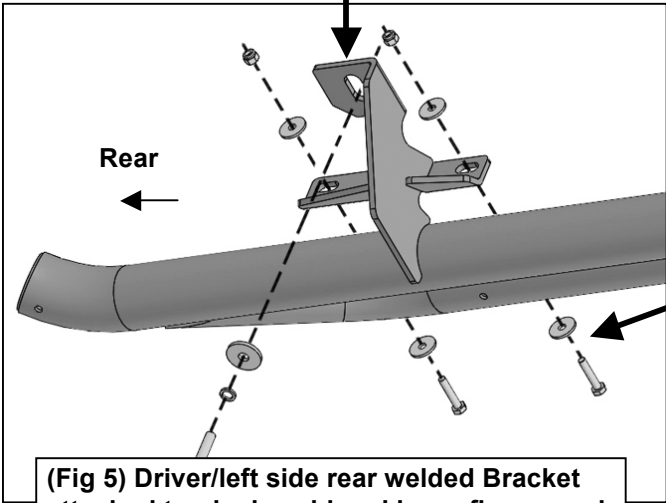

- (2) 6mm x 25mm Hex Bolts
- (4) 6mm Flat Washers
- (2) 6mm Nylon Lock Nuts

(Fig 5) Driver/left side rear welded Bracket attached to pinch weld and inner floor panel

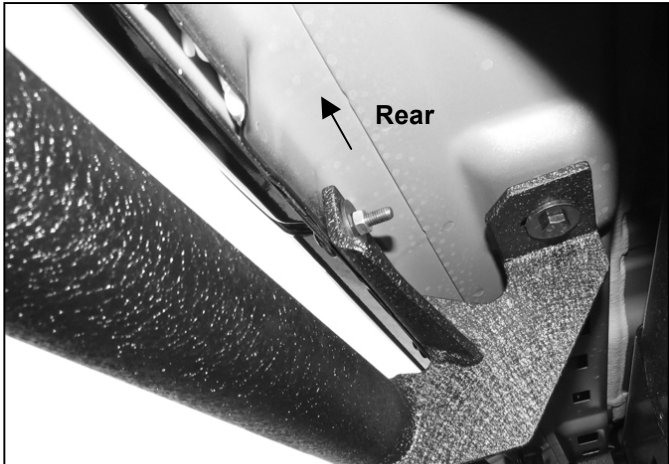

(Fig 6) Driver/left side rear welded Bracket installed



Complete Installation