



2015+ SUBARU LEGACY MUD FLAP INSTALLATION INSTRUCTIONS

PLEASE REVIEW THESE INSTRUCTIONS IN ITS ENTIRETY BEFORE ATTEMPTING INSTALLATION

To protect your Rally Armor mud flaps, **care must be taken during parking and reversing**. Rally Armor always recommends professional installation. Check wheel clearances after installation, especially on vehicles outfitted with non-OEM offset wheels and suspensions. Adjust accordingly.





Rally Armor is not responsible for damage or loss of installed mud flaps.

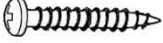

Each mud flap set contains 4 flaps, mounting hardware and brackets (unless otherwise noted).

Recommended tools: Philips Screwdriver, small & long flat head screwdrivers.

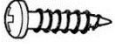
YOUR MOUNTING HARDWARE CONSISTS OF:			SCREW GUIDE	FASTENER GUIDE
Quantity	Hardware Item	Item ID		
2	Rear Brackets	HMF14/16-BR-RE		
2	Short Spacers	.25sp		
2	White Inserts	Ins7		
6	Flat Clips	UClip		
6	Polygon "Poly" Edge Clips	PolCl		
10	Stainless Steel Screws	1.5SS		
4	Stainless Steel Screws	1SS		
14	Washers	SmWash		

SCREW GUIDE	FASTENER GUIDE
1.5SS 	 INS7 (WHITE INSERT)
1SS 	 "POLY" CLIP  "FLAT" CLIP

! Important Notes

CAUTIONARY TIP: The hardware is strong and self-threading but over-tightening the mounting clips is not advised.

INSTALLATION TIP: To ease installation and avoid damage to existing OEM clips during removal, a well-lit, climate controlled installation environment is recommended.

TO THE INSTALLER: Please return these instructions to the customer after installation. Always test and check wheel clearances before returning vehicle.

TO THE CUSTOMER: Retain these instructions after installation. They may be necessary for installing other optional parts or removal of this accessory.

Front Mud Flap Installation

- **(Figure A)** Begin by parking the vehicle on an even surface. Turn the steering wheel as to allow access to the inner wheel well area. Remove the 4 OEM fender liner fasteners. Pull liner away to gain access to the interior fender area.
- **(Figure B)** Place 2 "Poly" edge clips (PolCl) over the two upper mounting tabs (as shown). Place "Flat" U clip (UClip) over the inner side skirt mounting hole. Replace liner over the mounting points. Replace original fastener underneath.
- **(Figure C)** Place the mud flap with the logo facing the rear of the vehicle, against the corresponding mounting points on the fender liner. Place a washer (SmWash) over a screw (1.5SS) through the flap into the each of the mounted clips. Important: For the lower inner mounting point, place a small spacer (.25sp) behind the mud flap. Align outer edge of the flap by incrementally adjusting the angle of the flap and bracket and walking away from the vehicle until the flap is perpendicular to even ground. Tighten all mounting screws and bracket bolt only until snug and flush with the surface of the mud flap. Do not over tighten the mounting points.

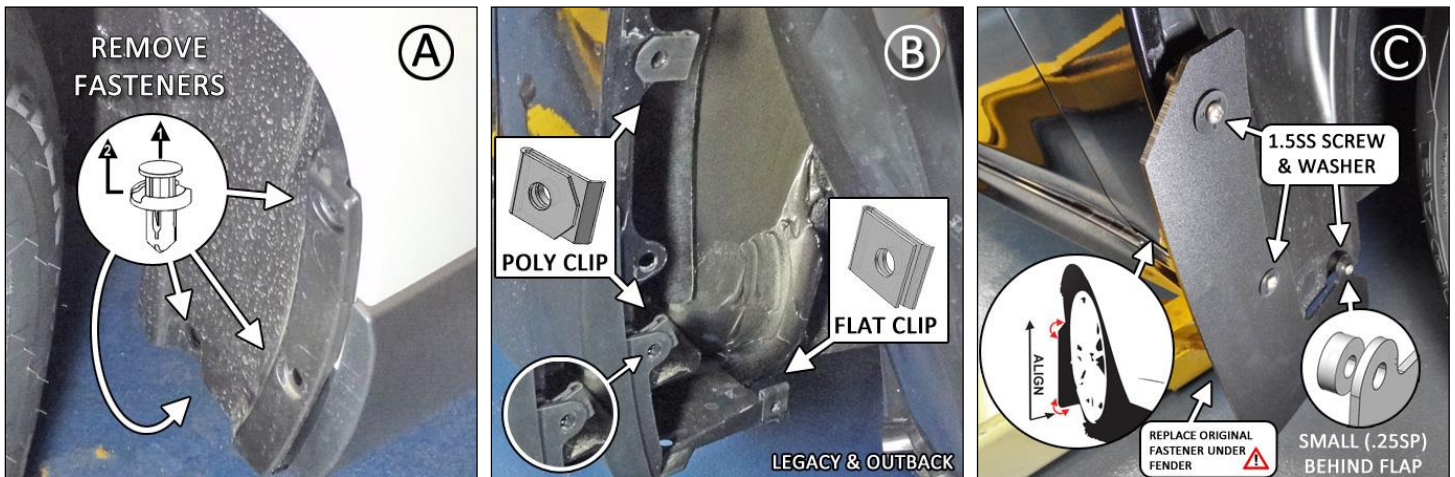

Rear Mud Flap Installation

- **(Figure D)** Place a "Flat" U clip (UClip) over each of the two outer bumper mounting points as shown.
- **(Figure E -Legacy)** Remove fastener underneath bumper cover. Place INS7 (white insert in the wheel well liner mounting point). Slide wheel well liner back into the bumper. Ensure insert is visible in liner through the mounting point in the bumper skin.
- **(Figure F- Outback)** Example of Figure (F).



- **(Figure G) Legacy**-Place wide mounting point of rear bracket between the bumper skin and the insert Place a washer (SmWash) over a screw (1.5SS) through the mounting point into the insert. Do not fully tighten as you will adjust the angle of the bracket during mud flap installation.
- **(Figure H) Outback example** of Figure (G)
- **(Figure I)** Place a polygon edge clip (PoICI) over the narrow mounting point of the bracket.

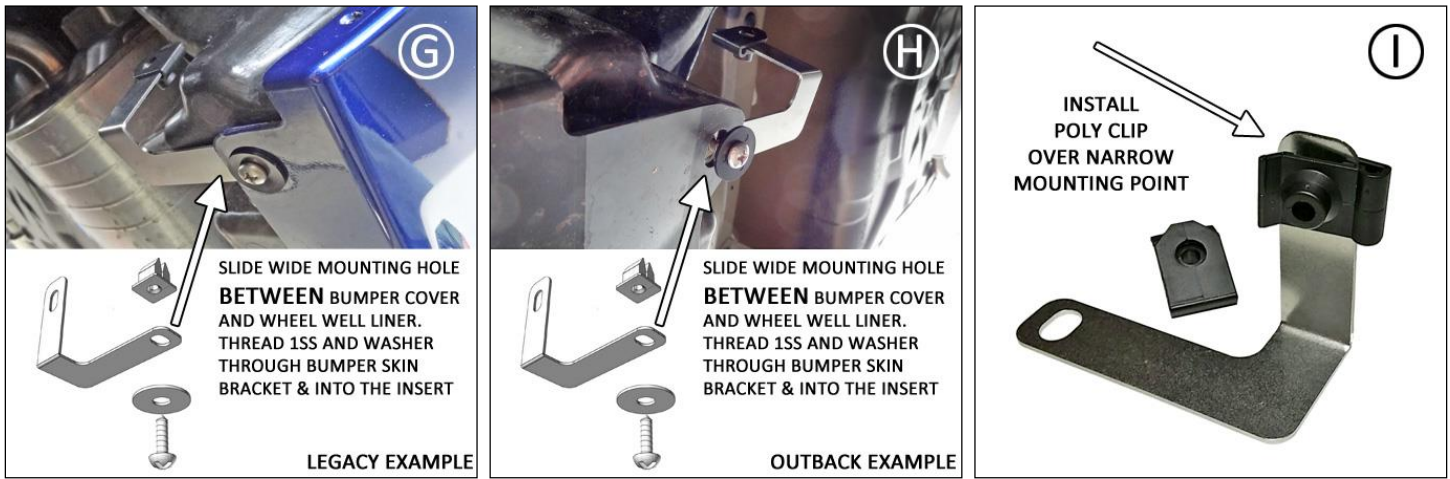

- **(Figure J)** Place the mud flap with the logo facing the rear of the vehicle, against the corresponding mounting points on the fender liner. Place a washer (SmWash) over a screw (1.5SS) through the flap into the each of the mounted clips. Adjust inner portion back to a parallel position, and to ensure proper tire clearance.
- **(Figure K)** Expanded view rear mounting. Leave mounting point loose during adjustment as to ensure the mud flap is flat.
- **(Figure L)** Align outer edge of the flap by incrementally adjusting the angle of the flap and bracket and walking away from the vehicle until the flap is perpendicular to even ground. Tighten all mounting screws and bracket screw only until snug and flush with the surface of the mud flap. Do not over tighten. Ensure mud flap is flush against mounting points by tightening all points only after alignment.

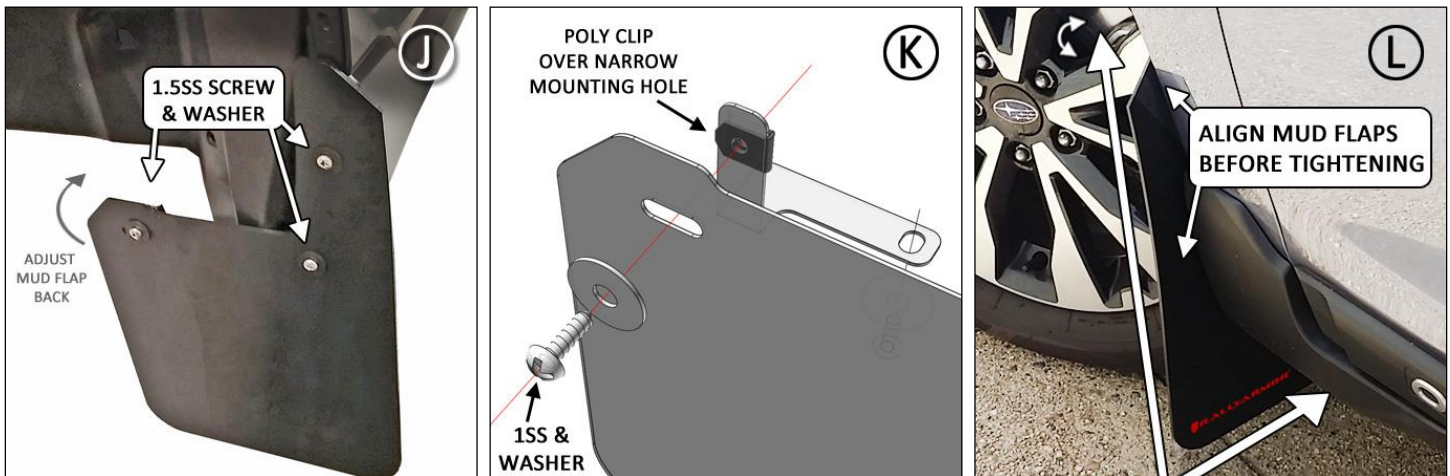

RALLYARMOR®
HMF - 34/36 MOUNTING DIAGRAM

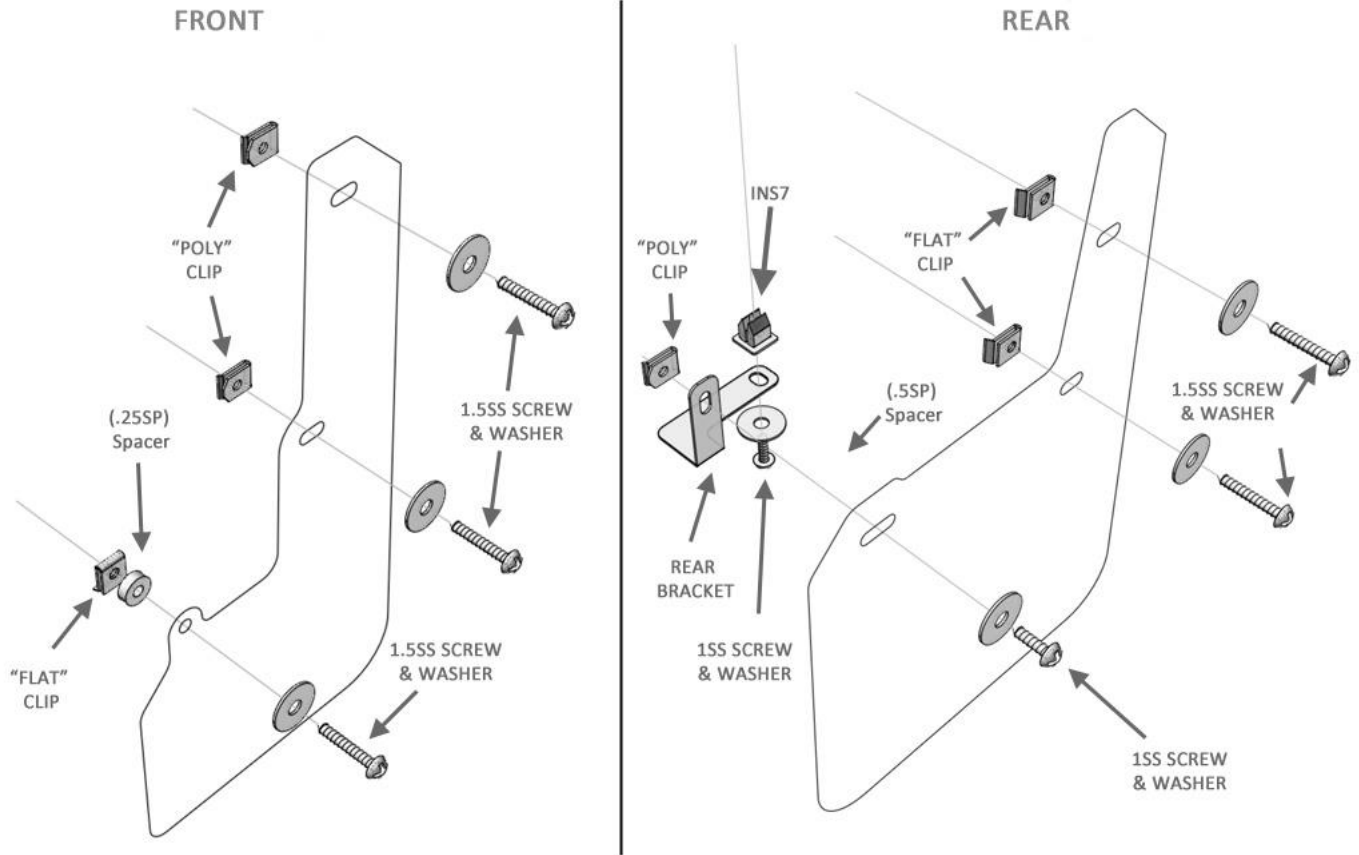

All content included on these instructions is the copyright of Rally Armor® LLC