



2012+ SUBARU IMPREZA 5dr HATCH/4dr SEDAN MUD FLAP INSTALLATION INSTRUCTIONS

PLEASE REVIEW THESE INSTRUCTIONS IN ITS ENTIRETY BEFORE ATTEMPTING INSTALLATION

To protect your Rally Armor mud flaps, **care must be taken during parking and reversing.** Rally Armor always recommends professional installation. Check wheel clearances after installation, especially on vehicles outfitted with non-OEM offset wheels and suspensions. Adjust accordingly.

Rally Armor is not responsible for damage or loss of installed mud flaps.

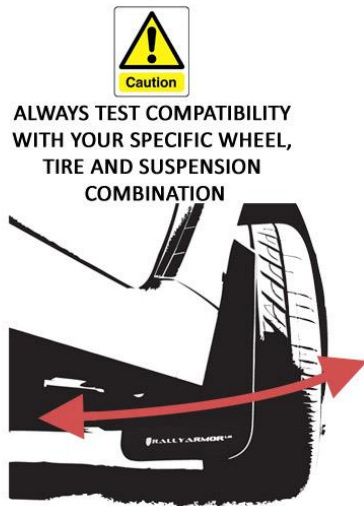

Each mud flap set contains 4 flaps and mounting hardware (unless otherwise noted).

Recommended tools: Offset or ratcheting screwdriver, short Phillips screwdriver, small & long flat head screwdrivers.

YOUR 2012+ IMPREZA MOUNTING HARDWARE CONSISTS OF:			HOW TO REMOVE STOCK FASTENERS:
Quantity	Hardware Item	Item ID	
2	Front brackets	HMF22-FR-BR	
2	Rear Brackets	HMF14/16-R-BR	
2	Side Skirt Front Spacers	SSK-SP	
10	Round Edge Clips	RoCl	
6	Polygon Clips	PolCl	
2	Plastic Inserts	Ins3	
14	Long Stainless Steel Screws	1.5SS	
2	Short Stainless Steel Screws	1SS	
16	Washers	SmWash	
2	Spacers	.5SP	
2	Front Screw Tip Covers	Scrwcvr	
2	White Inserts - 2015 and up	Ins7	
Important Notes Cautionary Tip: The hardware is strong and self threading but <u>over-tightening the clips is not advised.</u> Installation Tip: To ease installation and avoid damage to existing OEM clips during removal, a well lit, climate controlled installation environment is recommended.			<p>To the installer: Please return these instructions to the customer after installation. Always test and check wheel clearances before returning vehicle.</p> <p>To the customer: Retain these instructions after installation. They may be necessary for installing other optional parts or removal of this accessory.</p>

Front Mud Flap Installation

Begin by parking the vehicle on an even surface. Turn the steering wheel to allow access to the inner wheel well area.

- **(Figure A)** Remove fender liner clip. On side skirt equipped vehicles, remove first two retaining clips.
- **(Figure B)** Remove the four OEM fender liner fasteners (as shown). Carefully unclip front portion of side skirt by pulling the outer edge away just enough to release first two horizontal retainer clips. Pull liner away to gain access to the interior fender area.
- **(Figure C)** Place 3 supplied round edge clips (RoCI) over mounting tabs at an angle (as shown). Reinstall liner and side skirt.



- **(Figure D)** Side skirt equipped vehicles: angle front bracket (HMF22-FR-BR) **between the exposed section of the skirt and liner.** Interior portion of bracket is positioned against wall of wheel well. Place polygon clip (PoCI) over the inside bracket mounting point.
- **(Figure E)** Vehicles without side skirts: position front bracket (HMF22-FR-BR) **at an angle underneath and flush against liner.** Ensure inner bracket is positioned against the wall of the wheel well.
- **(Figure F)** Secure bracket by mounting insert (Ins3) FLUSH through the side skirt and bracket. Place polygon clip (PoCI) over the interior mounting point of the bracket. **⚠ Important- BEFORE mounting insert (Ins3), pull inner stem OUT.** Install the fastener where the OUTER assembly is flat against the body or side skirt. Push stem into retainer, locking it into place.

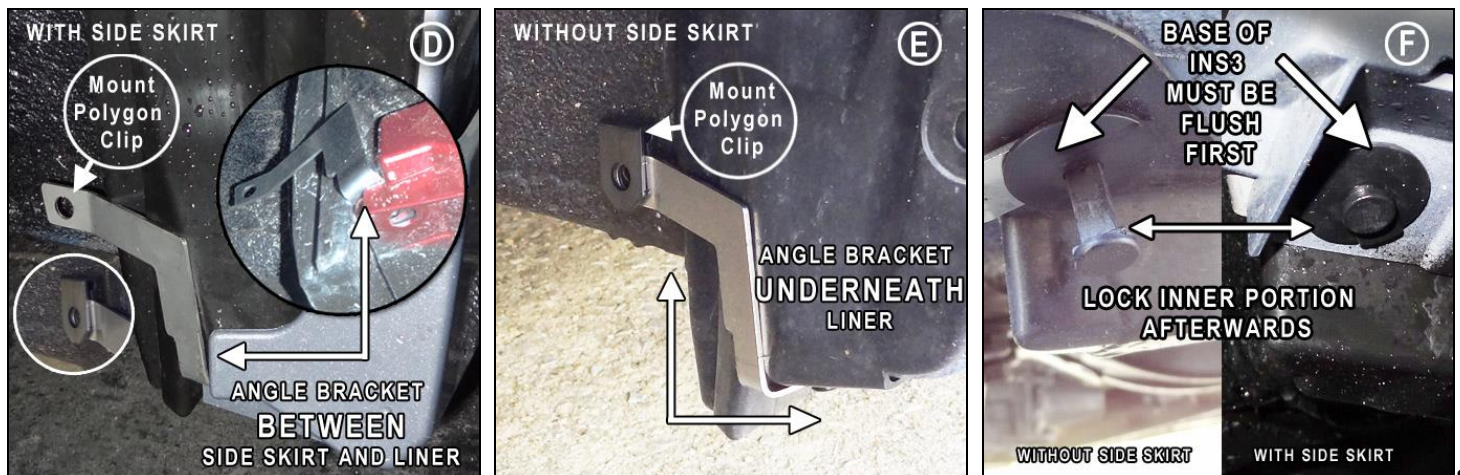

- **(Figure G)** Mount the front mud flap with the logo facing the rear of the vehicle. Place the front mud flap against the corresponding mounting points on the vehicle and bracket. Thread long screws (1.5SS) with washers (SmWash) through the flap and into each the 4 mounted clips. On the innermost mounting point of the bracket, place a spacer (.5SS) between the mud flap and polygon clip. Replace any remaining/unused side skirt and fender liner clips. **Do not fully tighten.** The mounting points are slotted to allow for movement and final alignment of flap. **⚠ IMPORTANT – ON SIDE SKIRT EQUIPPED VEHICLES ONLY:** utilize the front spacer (SSK-SP) for the upper two mounting points behind the mud flap. The spacer is correctly mounted when the upper edge with the smaller curve is positioned on the outer edge, behind the flap and even with the liner. Place Rubber Screw Tip Cover (Scrcvcr) over tip of screw behind mounting point. The cover can touch vehicle body.
- **(Figure H)** Align outer edge of the flap by incrementally adjusting the angle of the flap and walking away from the vehicle until the flap is perpendicular to even ground.
- **(Figure I)** Note Expanded Reference Diagram (page 5)

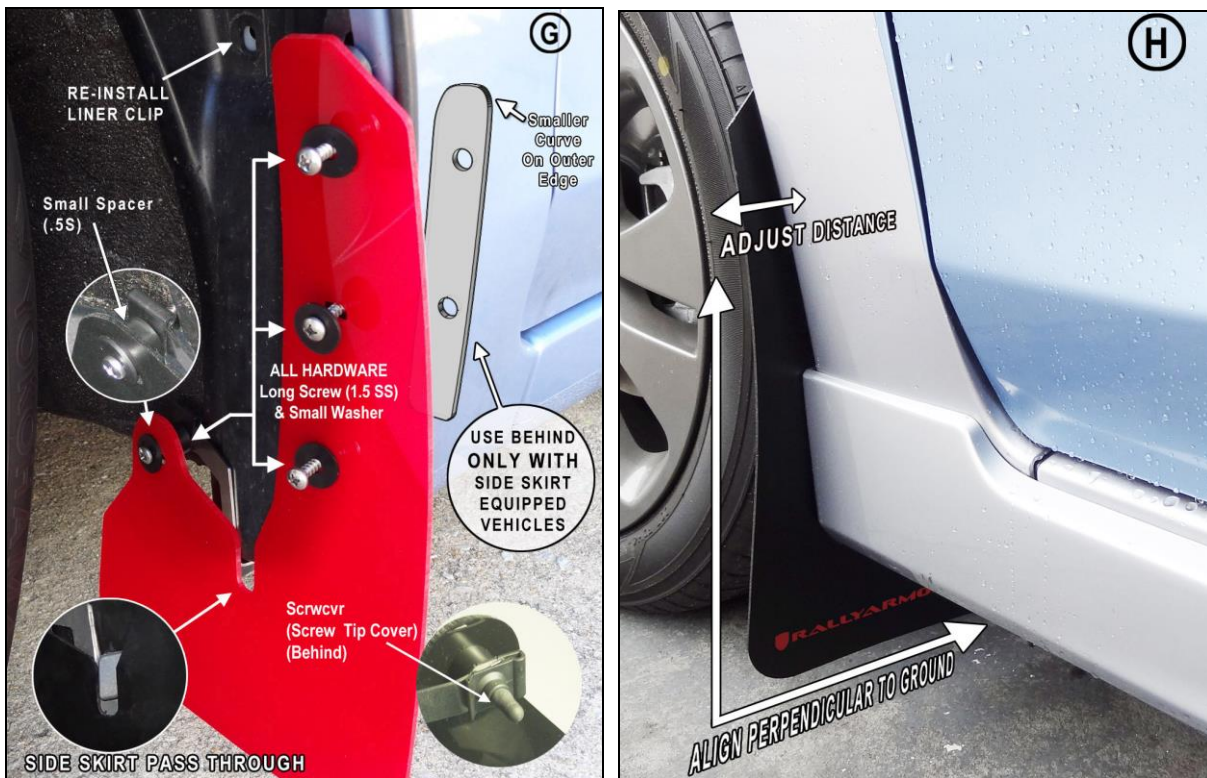

Rear Mud Flap Installation

- **(Figure J)** Place 2 round edge clips (RoCl) over the outer edge mounting tabs (as shown). Rear clips mount behind inner liner.
- **(Figure K)** Working from under the rear of the vehicle, remove bumper skin retainer clip(s).
- **(Figure L)** Gently pull back bumper skin. Install a polygon (PoCl) clip on the inside portion of the inner bumper piece.
- **(Figure L1)** For 2015+ Impreza owners, substitute the polygon clip for Ins7 (white insert)

TIP : You may choose to remove the inner bumper piece in its entirety to install the clip.

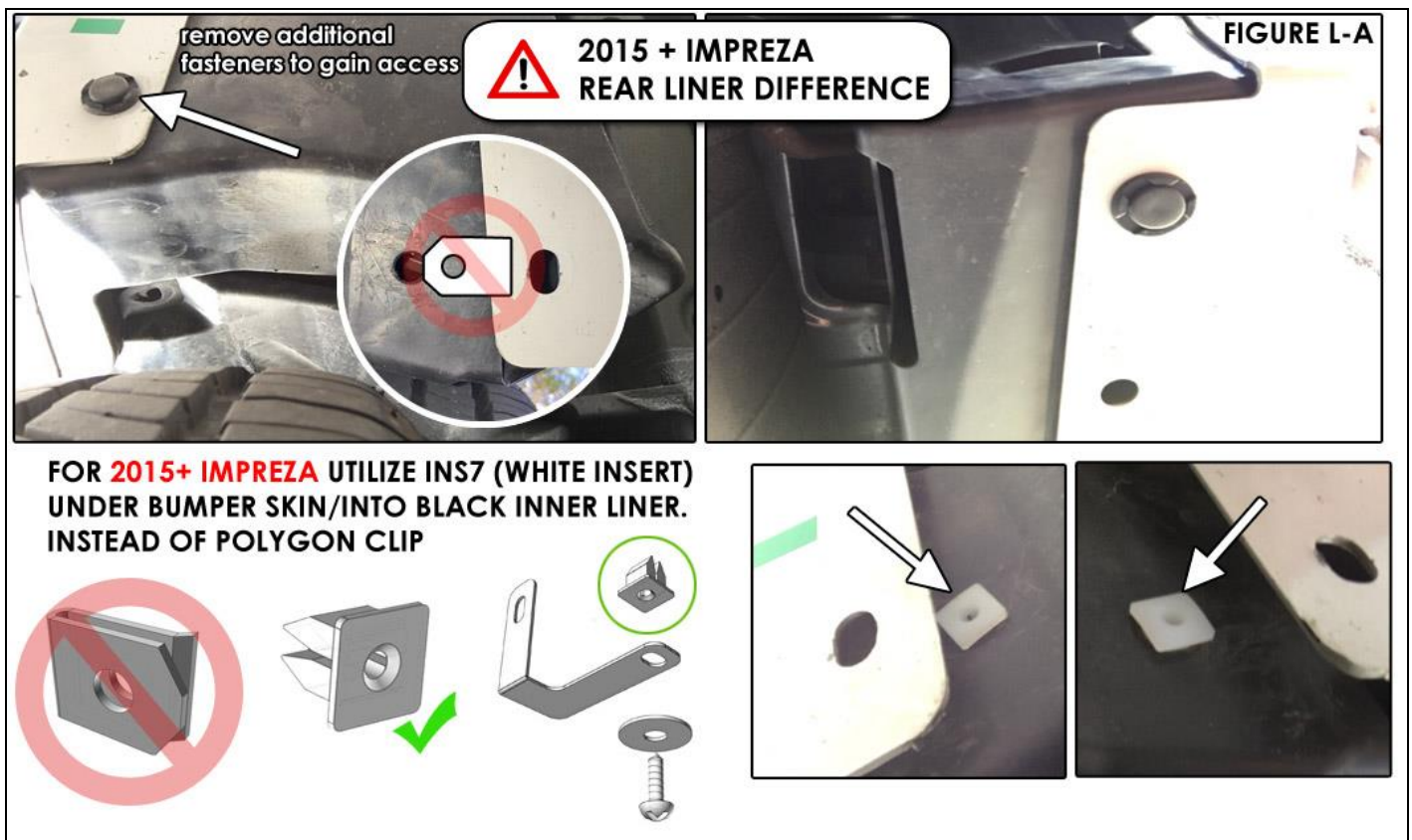

- **(Figure M)** Position the wider slot side of the bracket between bumper skin and inner bumper piece. Thread a long screw (1.5SS) with washer (SmWash) through the bumper skin, bracket and polygon clip (PoICI). **DO NOT TIGHTEN. You will need to adjust the bracket.**
- **(Figure N)** Place polygon clip (PoICI) over narrower slot of bracket. Push bracket back towards the rear of the vehicle.
- **(Figure O)** Mount the rear mud flap with the logo facing the rear of the vehicle. Place the mud flap against the corresponding mounting points on the vehicle and bracket. Thread a long screw (1.5SS) with washer (SmWash) through the flap into each of the 2

outer mounted clips. Thread a short screw (1SS) with washer into the inner mounting point. Do not fully tighten.

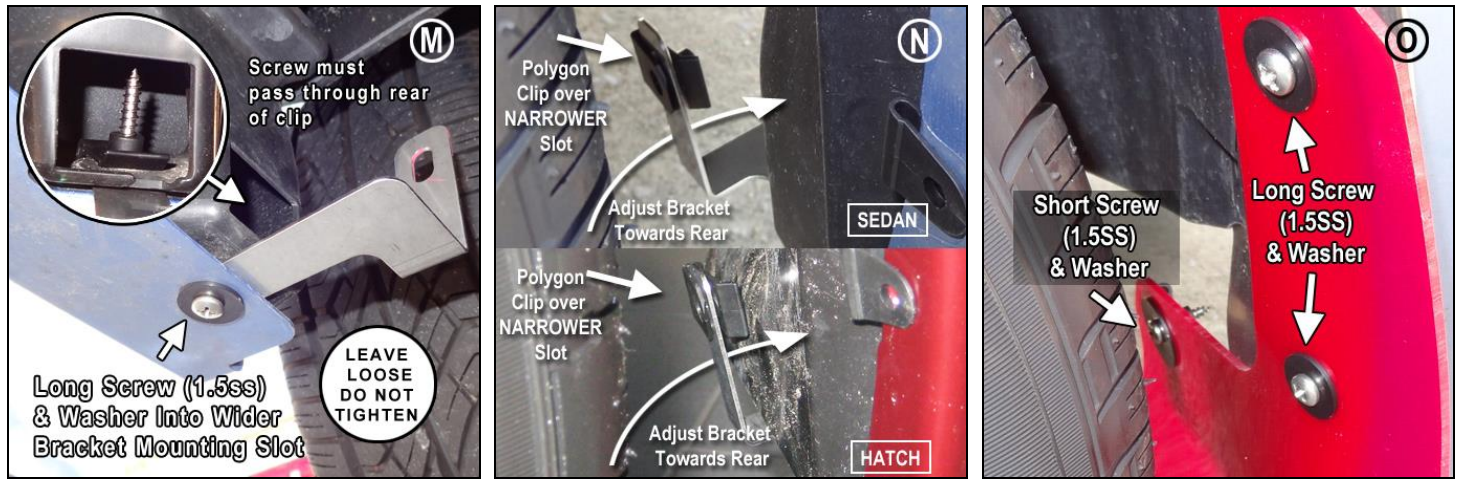

- (Figure P) Position the bracket back slightly, allowing for clearance between the flap and tire. Sedans have an open area while the innermost portion of the bracket on the hatch is mounted close to the bumper piece.
- (Figure Q) Align outer edge of the flap by incrementally adjusting the lower and upper portions and walking away from the vehicle until the flap is perpendicular to even ground. Tighten all mounting screws including bracket mountings points until snug. Do not over tighten.
- (Figure R) Note Expanded Reference Diagram (page 5)



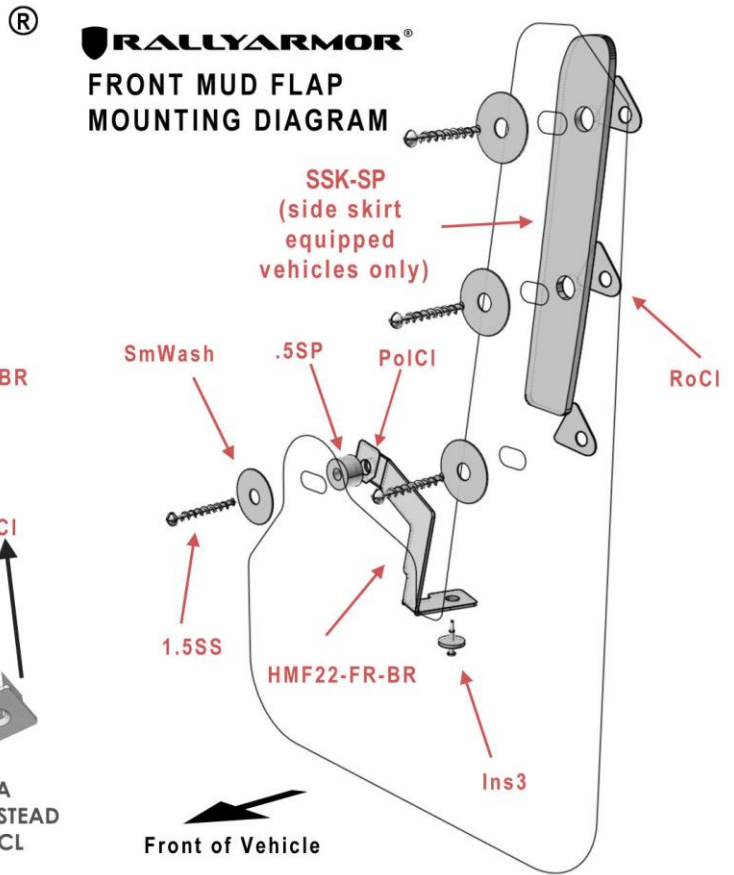
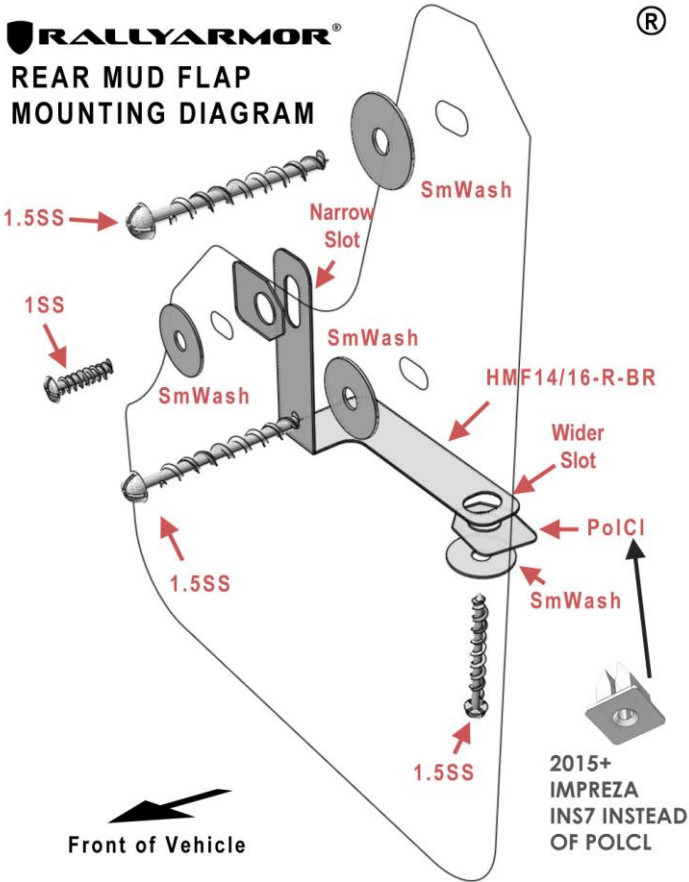

All content included on these instructions is the copyright of Rally Armor® LLC