

WARNING: DO NOT EXPOSE WORK AREA TO ANY SPARKS OR FIRE. DO NOT SMOKE WHILE OPERATING ON THE FUEL SYSTEM. CLEAN UP ALL FUEL SPILLS IMMEDIATELY. WORK IN A WELL VENTILATED AREA.

1. Disconnect battery negative terminal. Allow the engine to cool before working with the fuel system. Have a rag handy and purge fuel pressure from the system using the Schrader valve on the front of the OEM fuel rail.

Disconnect the 8 fuel injectors. Note that the wiring harness is specific to the firing order. If the wiring harnesses are removed, they must be reinstalled on the correct engine bank and to each specific injector.

Disconnect any wiring, vacuum lines, and throttle body components interfering with the installation process.



2. Using the included SAE disconnect tool, remove the fuel feed (14) hose and, if applicable, the return (13) hose. Catch all spilled fuel. Use a 10mm socket to remove the four M6 mounting bolts (12). The OEM bolts will not be reused.

Gently lift the fuel rails (2) up being careful to not lose anything. The injectors (6) will remain attached to the fuel rails. Remove from the vehicle and place onto a bench. NOTE: For the LS3 engine, permanently remove the intake plenum cover.

Pull out and discard all eight injector retaining clips (7). Cautiously pull and twist to remove the injectors. Note: the rail will contain residual fuel. Drain excess fuel into a safe container for disposal.

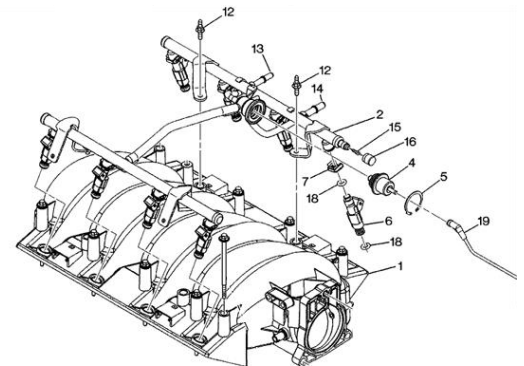

3. The included mounting feet allow installation of OEM injectors on various LS style intake manifolds. For instance, flipping the mounts over affects rail height. Securing them to the rail in specified holes affects fuel rail mount spacing.

First, measure the fuel rail mounting boss spacing on the intake manifold.

For intake manifolds which have 209mm spacing between the 2 fuel rail mounting bosses, install the mounting feet using the inner threaded holes and flip them so they are tall, as shown.

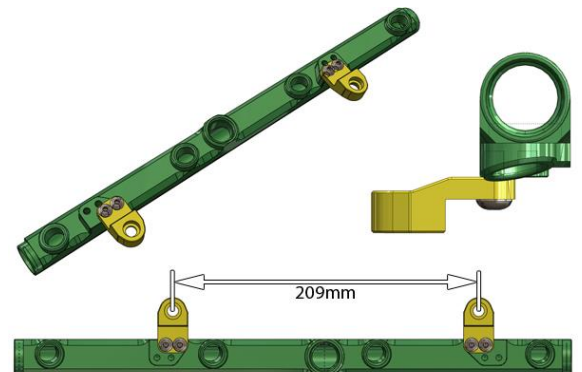

4. For intake manifolds which have 224mm spacing between the 2 fuel rail mounting bosses, install the mounting feet using the outer threaded holes and flip them so they are short, as shown.

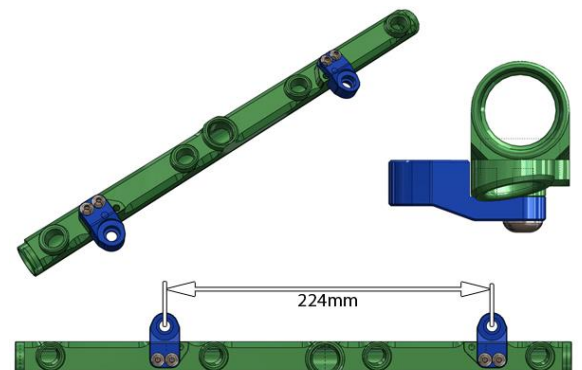

5. To secure the mounting feet to the rails, install the included split lock washer and M5 bolts (as shown).

Make sure the mounting feet are perpendicular to the rails.

Using a 3mm Allen hex wrench, torque to 68inlbs (7.7Nm).



6. Prepare to install the necessary adapter fittings into each fuel rail port. **To avoid damage, lubricate all O-rings with oil prior to installing.**

NOTE: A Direct Mount Regulator (DMR) can be installed in the outlet port (shown).

For the optional 20-0263 plumbing kit, install the two 8AN male fittings in the front ports where the crossover hose will be located. Install the 8AN ORB to 6AN male 90 degree fitting in the LH center inlet port and the 8AN ORB plugs in the unused ports.



7. Clean out any dirt or debris found in the intake manifold injector seat bores.

Before installing the fuel injectors, be sure the inlet cone filters are free from debris. Also, inspect the injector O-rings for any damage and replace if necessary.

For ease of installation, apply a light coat of oil to the injector O-rings, intake manifold injector seats, and fuel rail injector bores.

Fully insert the injectors into either the fuel rail bores or the intake manifold injectors seats (whichever is more conducive to the particular application).



8. Line-up and place each fuel rail assembly onto the intake manifold. Once everything is positioned correctly, push the rail towards the intake manifold to fully seat the injectors. Confirm all injector O-rings have been installed properly.

Note: On some LS engines, there are OEM brackets at the rear of one or both of the rails (shown in green). If there is interference, slight modifications to these brackets may be required.

Using a 5mm Allen wrench, torque the 4 bolts to 89inlbs (10Nm).

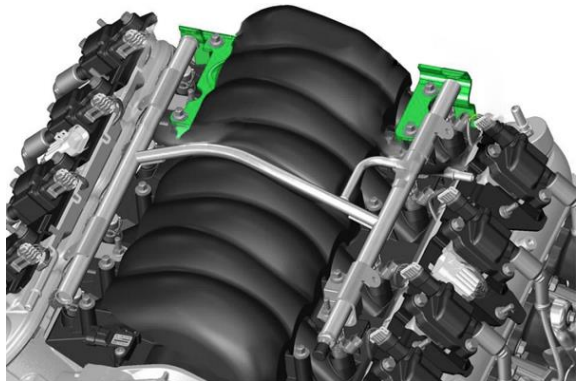

9. The 20-0232 fuel rail does not include plumbing. NOTE: Early LS1 engines (97-99) will require an aftermarket FPR to replace the regulator on the OEM rail.

For the optional 20-0263 plumbing kit, install the crossover hose to the front - 8AN fittings. Next, install the 90 degree coupler and 3/8" SAE male fitting to the LH center inlet fitting. Orientate the 3/8" SAE male fitting towards the left of the vehicle. Lubricate and push the OEM feed hose onto the 3/8" SAE fitting (as shown) until a click is felt. Gently pull to test the connection.



10. Reinstall all components previously removed.

Cycle the key a few times (without starting engine). This purges the system of air and allows the fuel pump to prime the system.

CHECK FOR LEAKS! If no leaks are found, start the engine and check again while the engine is running.

NOTE: OEM fuel pressure is 4 bar (GM states "55-60psi").

Installation complete.

