

Connector Assembly

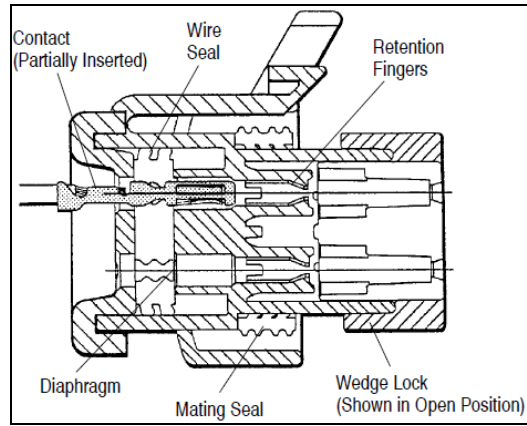

1. Verify the wedge lock is in the open position (shown above).
2. Insert socket and push in straight into the selected circuit cavity as far as it will go (shown below)
3. Gently pull back on socket/wire to be sure the retention fingers are holding the socket

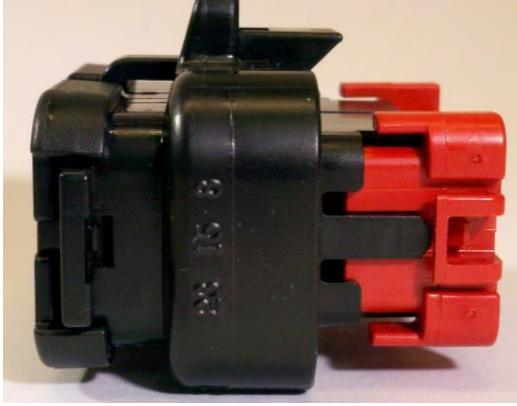
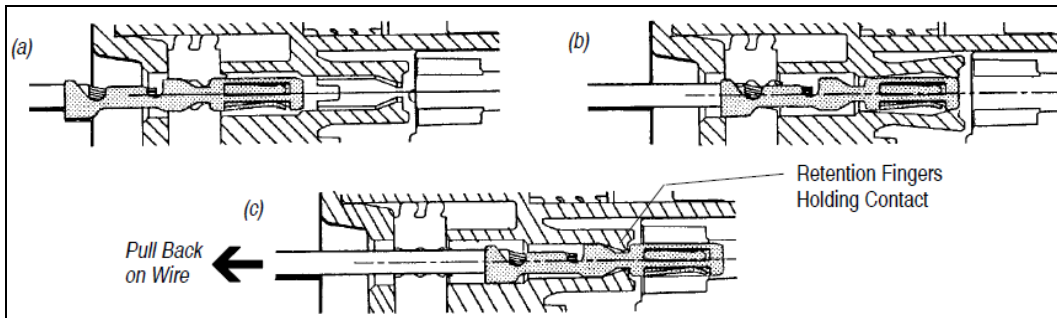

4. After all wire/sockets have been inserted, the wedge lock must be closed to its locked position.
5. Release the locking latches by squeezing them inward (shown below)

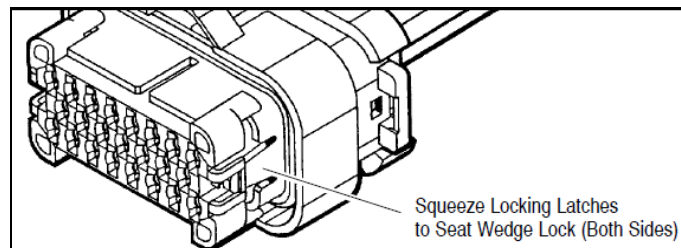

6. Slide the wedge lock into the housing until it is flush with the housing (shown below)

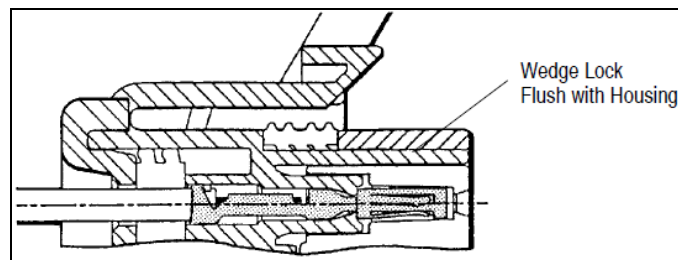

Connector Disassembly

1. Do not damage the connector during disassembly. As shown below, insert small screw driver between mating seal and one of the red wedge lock tabs.

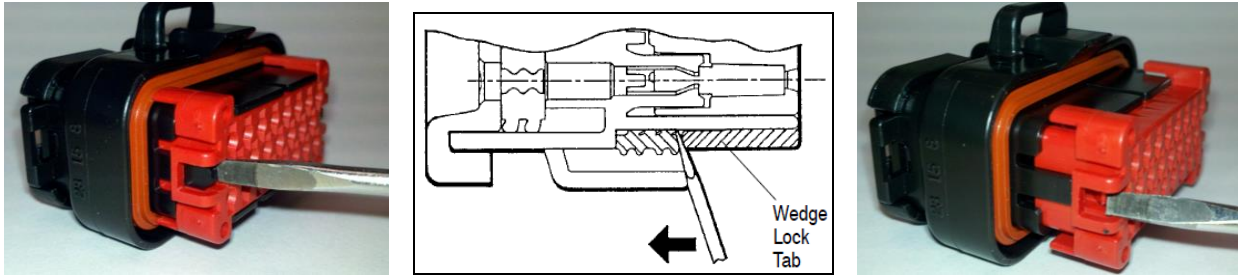

2. Gently pry open the wedge lock to the open position.
3. While rotating the wire back and forth (at least a 1/4 turn in each direction), gently pull the wire until the wire/socket is removed.

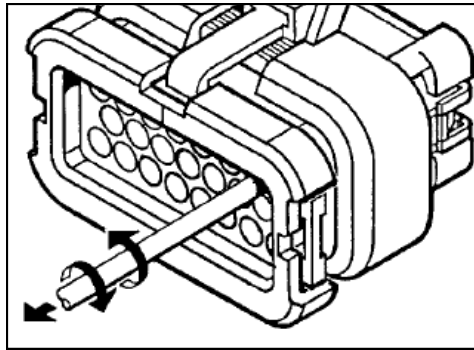

NOTE: The wedge lock should never be removed from the housing for insertion or removal of the sockets.

Seal Plug

All circuits are sealed by a diaphragm in the rubber wire seal. During plug connector assembly, the diaphragm is pierced as the contact passes through it. Unused circuit cavities, unless accidentally perforated, will remain sealed. A seal plug is available and designed to keep out contaminant if the diaphragm is pierced.

To install seal plug, insert seal plug large end first, into circuit cavity as far as it will go. An insertion tool is not required. (See below)

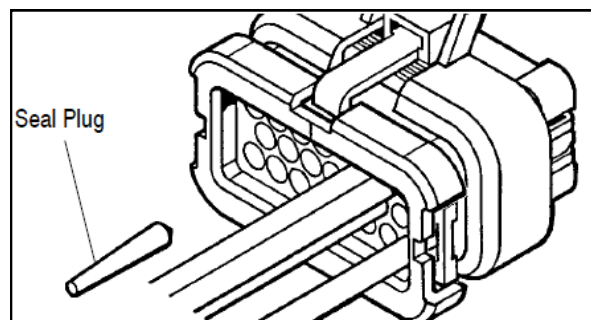

Socket Crimping

The sockets should be crimped and then inspected for conditions shown below:

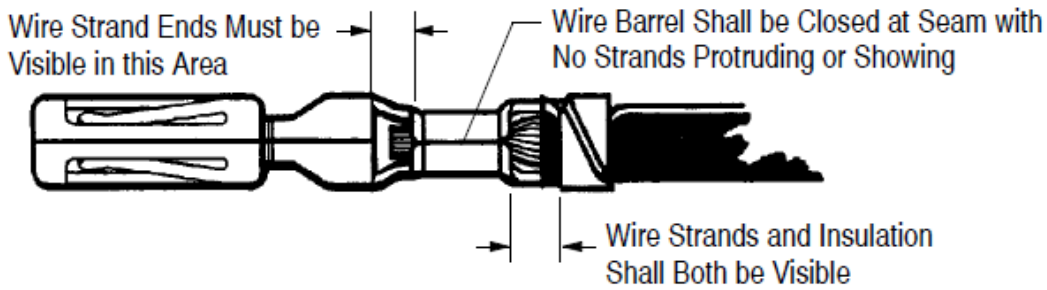

Proper Crimping on wire insulation required for socket to insert correctly.

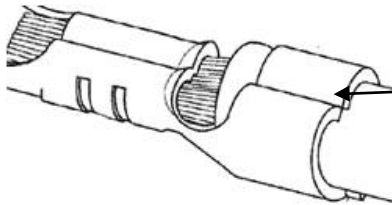

Incorrect
End should be completely round

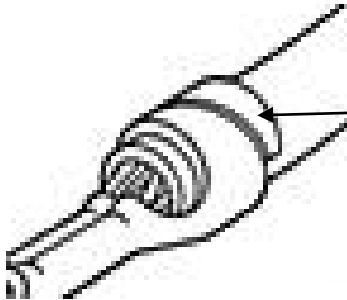

Correct
Completely round



NOTE: Wire stripping tool jaws may leave corrugated indentations on the surface of the wire insulation. This is especially severe with cross-linked polyethylene (high temperature) insulation. If these indentations occur at the location of the wire seal, leakage may result. Insulation surface within 26 mm from the tip of the contact must be smooth and free of residual indentations.



Care should be taken to ensure that the wire insulation is not cut or broken during the crimping operation, and to ensure that the insulation is not crimped into the wire barrel.



The ends of the insulation barrel shall be wrapped around the wire insulation, leaving no sharp points to damage the rubber wire seal.

SmartWire 23 Pin Connector Pinout

Pin numbers are located on wire connector.
SmartWire unit is labeled A or B above each port.

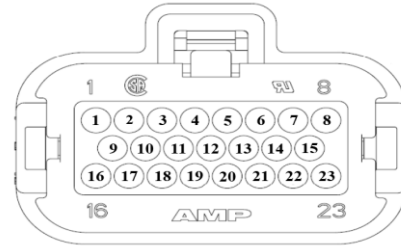

Table 1 - Input Pins (hardwired direct)

"A" Connector		"B" Connector	
PIN#	Input Channel#	PIN#	Input Channel#
10	1	10	7
11	3	11	8
12	4	12	9
13	5	13	10
14	6	14	11
18	2	18	12

Defaulted Channel name in software shown below

SM1 Inputs

Table 2 - 20 Amp Output pins

"A" Connector			"B" Connector		
PIN#	Output Channel#	AMP	PIN#	Output Channel#	AMP
1	4	20	1	5	20
3	1	20	3	7	20
6	2	20	6	8	20
8	3	20	8	6	20

Defaulted Channel names in software shown below

SM1 Output #1	SM1 Output #5
SM1 Output #2	SM1 Output #6
SM1 Output #3	SM1 Output #7
SM1 Output #4	SM1 Output #8

Table 3 - 10 Amp Output pins

"A" Connector			"B" Connector		
PIN#	Output Channel#	AMP	PIN#	Output Channel#	AMP
2	10	10	2	22	10
4	11	10	4	28	10
5	13	10	5	25	10
7	15	10	7	26	10
9	12	10	9	21	10
15	20	10	15	27	10
16	9	10	16	18	10
17	19	10	17	24	10
21	14	10	21	23	10
22	16	10	22	29	10
23	17	10	23	30	10

Defaulted Channel name in software shown below

SM1 Output #9	SM1 Output #20
SM1 Output #10	SM1 Output #21
SM1 Output #11	SM1 Output #22
SM1 Output #12	SM1 Output #23
SM1 Output #13	SM1 Output #24
SM1 Output #14	SM1 Output #25
SM1 Output #15	SM1 Output #26
SM1 Output #16	SM1 Output #27
SM1 Output #17	SM1 Output #28
SM1 Output #18	SM1 Output #29
SM1 Output #19	SM1 Output #30

Table 4 - Other

"A" Connector		"B" Connector	
PIN#	Function	PIN#	Function
19	Ground	19	Ground
20	Ground	20	Shutdown