



## LAKEWOOD/QUICKTIME SAFETY BELLHOUSING INSTALLATION INSTRUCTIONS

Congratulations on your purchase of the finest quality steel bellhousing available today. 100% Manufactured in the USA!

Please understand that Lakewood/QuickTime safety bellhousings are not vehicle specific. They are designed to adapt specific engines to specific transmissions and may require you to do some minor work to make it fit your particular vehicle.

**NOTICE:** Bellhousings that meet S.F.I. (Safety Foundation Institute) specification 6.1 are supplied with an engine block plate and maximum containment fasteners that must be used. It is highly recommended that an S.F.I. approved flywheel and clutch assembly be used in conjunction with these bellhousing for additional safety precautions.

**CAUTION:** Installation of this safety bellhousing requires working underneath vehicle. **USE EXTREME CAUTION WHEN WORKING UNDERNEATH THE VEHICLE. Never get near or underneath the vehicle until you are confident that it is safely supported and will not move or fall from its raised position. DO NOT USE A BUMPER JACK!**

All bellhousings include fasteners to mount the bell to the engine, clutch fork pivot ball or pivot brackets where required, and containment hardware to fasten the block plate to the bell on 6.1 S.F.I. approved housings. Additional parts such as adapter/reducer rings and brackets are included in many of our bellhousings due to various applications, but might not be needed in your particular installation. Transmission mounting bolts are NOT included, but all bellhousings are designed to use the stock factory transmission mounting bolts.

### STARTER MOTORS

Bellhousings are designed to be used with factory OE starters or equivalent except where noted in our catalog. Small compact high torque mini starters will work with all Lakewood/QuickTime bellhousings. Bellhousings for Chrysler applications include 1-reducer bushing for the lower starter mounting bolt.

### FLYWHEELS

Most Lakewood/QuickTime bellhousings are designed for use with factory size flywheels, except for size limitations where noted in our catalog.

**IMPORTANT:** Always check and confirm fitment before final installation. It is recommended to check fit the transmission into the bellhousing before mounting it to the engine.

### PREPARATION FOR INSTALLATION

1. Place vehicle on a solid, level surface such as a garage floor to ensure safe installation.
2. Raise vehicle using appropriate lifting device and support it using automotive approved support stands having adequate load capacity.

3. Disconnect the negative (-) cable from the battery.

**CAUTION: DO NOT BEGIN THIS INSTALLATION UNTIL YOU ARE CONFIDENT THAT THE VEHICLE IS SECURE AND SAFELY SUPPORTED!**

### INSTALLATION INSTRUCTIONS

1. Remove driveshaft, starter motor, transmission and stock bellhousing.
2. Remove pressure plate and clutch disc from flywheel.
3. At this point, we recommend that you check your Safety Bellhousing for proper alignment with the crankshaft. This is not a difficult procedure. Detailed instructions outlining the necessary steps along with recommendations for correcting any misalignment are included with these instructions.
4. After checking and correcting bellhousing alignment, remove flywheel and install blockplate. Use blockplate as is (the round hole in the blockplate will correctly locate the starter nose assuring proper alignment). Install blockplate over the crankshaft flange and place over dowel pins in the block.

**IMPORTANT:** In order to comply and meet S.F.I. bellhousing specification 6.1, it is mandatory that the safety blockplate be installed with 6.1 bellhousings and all containment fasteners supplied be used.

5. Reinstall flywheel and clutch assembly. Be sure to tighten fasteners using manufacturers recommended torque specifications.

**NOTE:** We recommend the use of Mr. Gasket Ultra-Seal premium fasteners for clutch and flywheel installation when available.

**IMPORTANT:** Do not reuse the factory cast iron flywheel! A high performance quality billet flywheel that meets S.F.I. specifications is recommended for safety purposes. Hays offers a complete line of high performance clutches and flywheels that meet safety requirements.

## **CLUTCH FORK PIVOT BALL AND PIVOT BRACKETS**

6. Determine if your installation requires a pivot ball or pivot bracket for the clutch fork. If you are using a hydraulic bearing release set up, proceed to step number 7.

**GM APPLICATIONS** (Chevy, Pontiac, Oldsmobile, Buick) Most bellhousings for GM applications include a pivot ball for the clutch fork located in the bellhousing on the driver's side.

**CHRYSLER/MOPAR APPLICATIONS** Most bellhousings for Chrysler applications include two-pivot brackets for the clutch fork. One for "A" body vehicles and one for "B" or "E" body vehicles. Select the bracket that is correct for your application and mount inside the bellhousing using the two-button head cap screws supplied.

**FORD APPLICATIONS** Some bellhousings for Ford applications include both a pivot ball located on the passenger side for cable operated clutch forks, and two-pivot brackets for mechanical clutch fork operation. One that is used with a "spring" style clutch fork and one that is used with a "wire" style clutch fork. If your installation requires the use of a pivot bracket, you will not need the pivot ball and it should be removed. Select the bracket that is for your application and mount inside the bellhousing using the two-button head cap screws supplied. Note: A spacer measuring .600" thick is included for installations where the clutch fork pivot bracket needs to be located closer to the clutch assembly.

## **ADAPTER/REDUCER RINGS**

7. Some GM, FORD AND CHRYSLER/MOPAR installations will require the use of an adapter/reducer ring for the bearing collar on the transmission so that it fits securely into the bellhousing. Adapter/reducer rings are included where necessary. Determine the correct adapter/reducer ring required for your installation by fitting it onto the transmission bearing collar and then inserting it into the bellhousing transmission mounting flange.

**NOTE: Some transmissions will fit directly into the bellhousing without the need of an adapter/reducer and no rings are included. The 6-speed T-56/Magnum transmissions do not require an adapter/reducer ring.**

8. Position your bellhousing over the flywheel/clutch assembly and slide onto dowel pins in engine block. Fasten the bellhousing to the engine block using the grade 8 bolts supplied. Make sure the fasteners supplied have the same thread size/pitch as the factory threads. Secure the blockplate to the bellhousing using the grade 8 bolts, lock washers and nuts supplied.

**IMPORTANT: All fasteners must be used in their proper location for the bellhousing to meet S.F.I. specification 6.1**

**NOTE: All fasteners for the engine side or transmission side should be torqued between 35 and 45 ft/lbs to maintain parallelism. It is more important that they are all torqued the same more than whether it is 35 or 45 ft/lbs.**

9. Replace starter motor, transmission and driveshaft.

10. Attach clutch linkage if applicable and check for proper adjustment.

11. Reconnect battery.

**RETAIN THIS INSTRUCTION SHEET FOR FUTURE REFERENCE**

## BELLHOUSING ALIGNMENT PROCEDURE

Due to manufacturers' machining tolerances of engine blocks in relationship to dowel pin location, it is quite possible for the crankshaft centerline and bellhousing bore to be misaligned. With the transmission installed in a misaligned condition, several problems can occur, such as pilot bearing and main shaft bearing wear, difficulty in shifting, and in extreme cases, breakage of transmission gears and case.

While most bellhousings will fall within the allowable limits, it is good practice to check for register bore run out whenever any bellhousing or engine block is installed. Most factory service manuals will outline the checking procedure, but will not give correctional measures necessary to ensure trouble-free standard transmission operation, short of trial and error with switching of various O.E. housings.

Offset dowel pins are available from Lakewood Industries to ensure correct bellhousing installation. For checking, you will need a dial indicator (preferably with a magnetic base), a few simple tools and close attention to detail to give you accurate installation results.

**Special note for bellhousings that are designed for T-56 transmissions:** In order to check register bore run out on these bellhousings, you must remove the front plate from the transmission and mount it to the bell. This will allow you to check for run out by following the instructions below.

1. Remove clutch assembly from flywheel and install bellhousing on engine block. (It is easier when you leave the clutch assembly off the flywheel.)
2. Install dial indicator base on the flywheel and adjust plunger to contact the register bore of the housing.

3. Rotate the flywheel and note indicator reading. Misalignment is one-half of the indicator reading (maximum allowable is .005").
4. To correct off-center condition, select the offset dowel pin pair that is closest to one-half of the indicator reading. (i.e., if reading is .016", 1/2R=.008" use .007" dowels. If reading is .024", 1/2R=.012" use .014" dowels).
5. Remove stock dowel pins by driving out from back side or pulling out with gripper pliers.
6. Clean engine block dowel holes and coat lightly with lubricant.
7. Lubricate dowel pins and install in block. Note the position of the offset and mark the dowel for reference. They should be installed parallel to one another and in pairs (both .007", .014" and .021").
8. Install and tighten bellhousing securely. Remount the dial indicator and recheck the register bore run-out (Repeat step 3).
9. To make small corrections or adjustments to the alignment, you will need to remove the bellhousing and drive the offset dowels out of the block. Reposition the dowels and re-check register bore run-out. Repeat this procedure until the register bore is within limits.

**NOTE: Always be careful when removing bellhousing from engine block so that offset dowel pins do not move or change position.**

Total Indicator Reading	One-Half Total Indicator Reading	Size Dowel To Be Used	Lakewood Offset Dowel Part Number	
			GM .625" dia.	Ford/Mopar .500" dia.*
.012" to .020"	.006" to .010"	.007"	#15920	#15950
.022" to .034"	.011" to .017"	.014"	#15930	#15960
.036" to .052"	.018" to .026"	.021"	#15940	#15970

\*Off-set dowel pins are not available for Ford 4.6/5.4L engines

### WELD-ON DOWEL LOCATING KIT

Designed for use on race cars that are frequently dis-assembled, this kit eliminates the need to "dial- in" the bellhousing after each removal. Ford/Mopar engines with .500" dowel holes use #15980. GM engines with .625" dowel holes use #15981.

**NOTE: Welding is required to use this kit.**

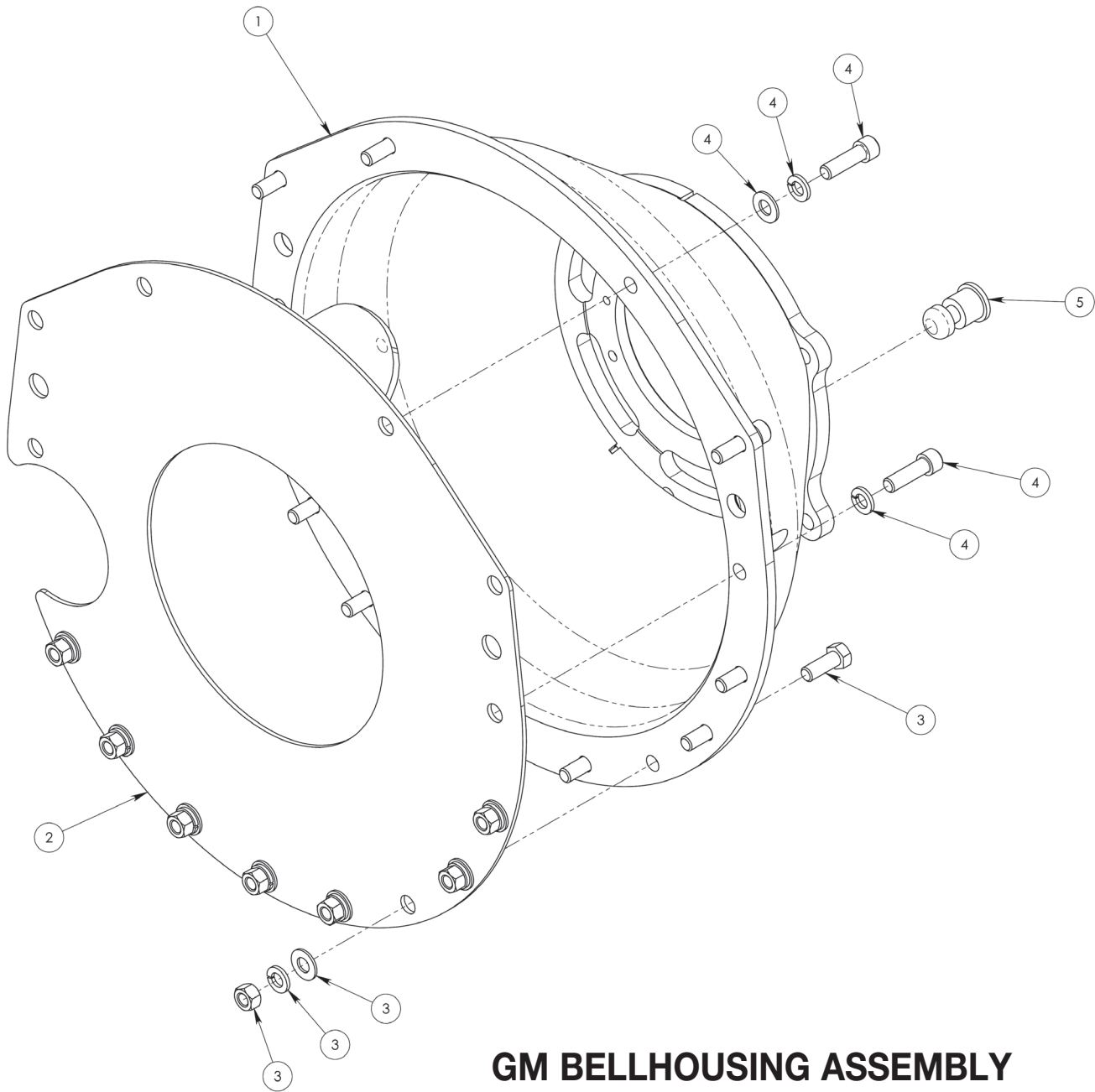

## GM BELLHOUSING ASSEMBLY

### GM BELLHOUSINGS (Chevy, Pontiac, Oldsmobile, Buick)

- #1 Bellhousing
- #2 Engine/Block Plate
- #3 Containment Hardware for block plate to bellhousing  
(Includes bolts, flat washers, lock washers, nuts)
- #4 Fastener Hardware for bellhousing to engine  
(Includes bolts and lockwashers)
- #5 Pivot Ball for clutch fork

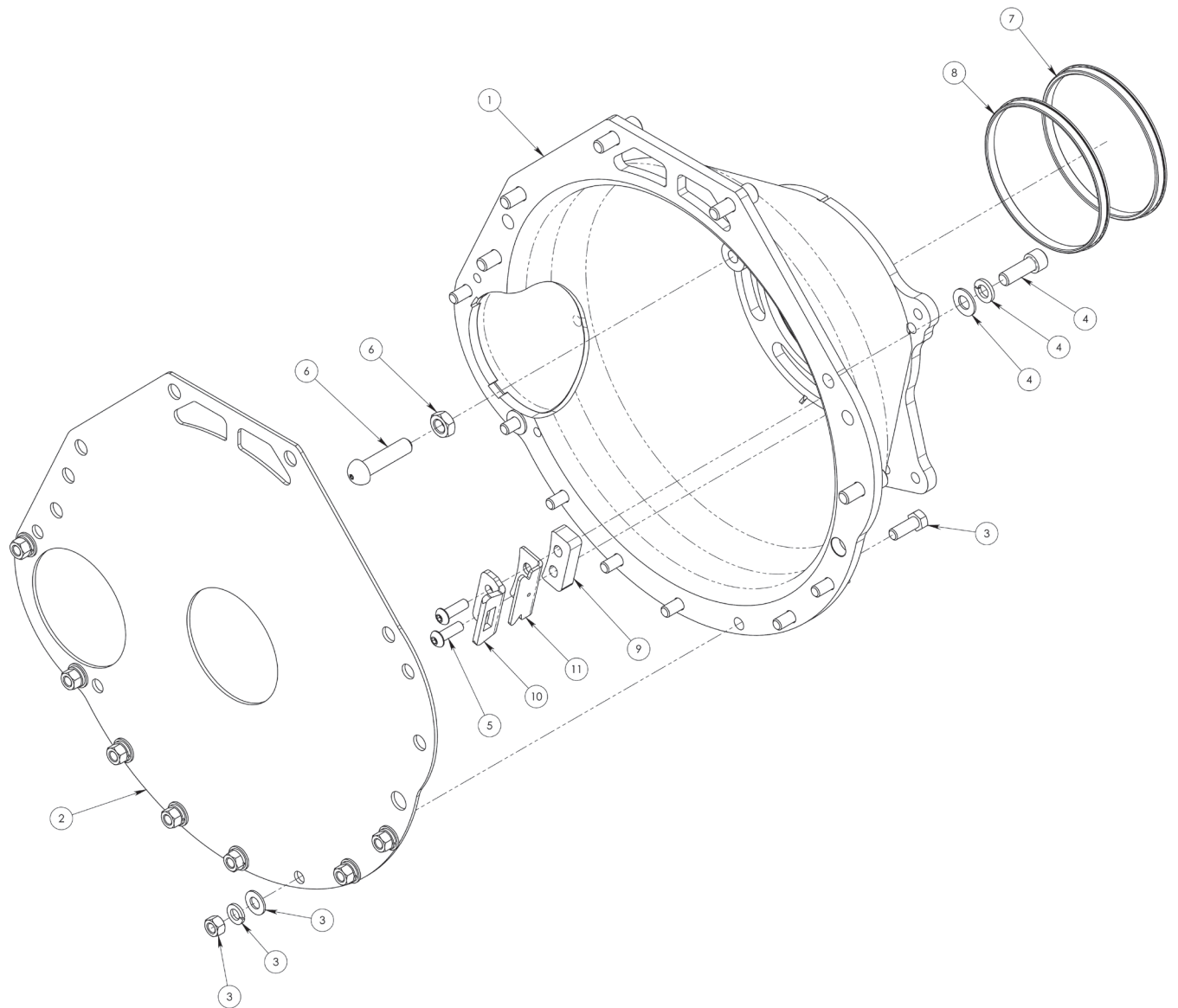

## FORD BELLHOUSING ASSEMBLY

### FORD BELLHOUSINGS

- #1 Bellhousing
- #2 Engine/Block Plate
- #3 Containment Hardware for block plate to bellhousing  
(Includes bolts, flat washers, lock washers, nuts)
- #4 Fastener Hardware for bellhousing to engine
- #5 Button head capscrew (quantity 2)
- #6 Pivot Ball and Jam Nut for clutch fork
- #7 Adapter/Reducer Ring 4.850" ID
- #8 Adapter/Reducer Ring 4.910" ID
- #9 Pivot bracket spacer
- #10 Pivot Bracket for clutch fork (spring style)
- #11 Pivot Bracket for clutch fork (wire style)

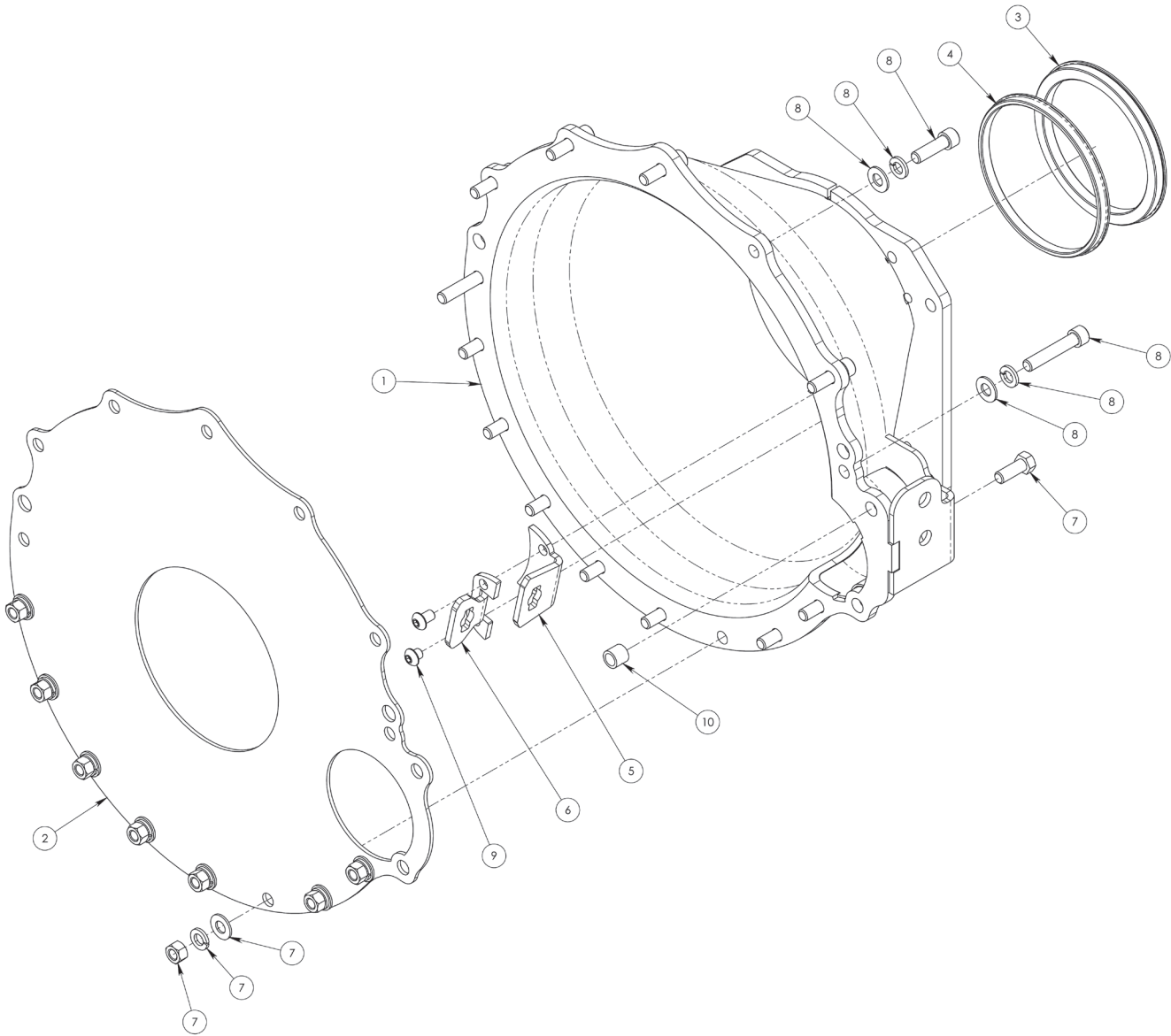

## CHRYSLER BELLHOUSING ASSEMBLY

### CHRYSLER/MOPAR BELLHOUSINGS

- #1 Bellhousing
- #2 Engine/Block Plate
- #3 Adapter/Reducer Ring 4.350" ID
- #4 Adapter/Reducer Ring 4.810" ID
- #5 Pivot Bracket for clutch fork (B&E body)
- #6 Pivot Bracket for clutch fork (A body)
- #7 Containment Hardware for block plate to bellhousing  
(Includes bolts, flat washers, lock washers, nuts)
- #8 Fastener Hardware for bellhousing to engine  
(Includes bolts and lockwashers)
- #9 Button head capscrew (quantity 2)
- #10 Reducer bushing for starter motor