



quarantineTM
resistants.it d



***Multi-Functional
Cargo Restraint Systems***

innovation in cargo securement

Product Catalogue 2016 / 2017



Why We Are in Business

"We believe in innovation and purpose; in creating products that happen to reflect the same core values of our loyal customers. A confirmation that you believe in what we do, too.

And what we do is simple. We never stop believing that there is a better way to advance all things we are involved in.

Quarantine Restraints product line is just that. A creative solution to an industry's ongoing safety concern."

- Team Quarantine

Innovation in Cargo Securement

Quarantine Restraints designs and manufactures interior and exterior cargo safety restraints for light to medium duty vehicles. Developed through years of research, engineering and testing, Quarantine Restraints combine the highest level of performance with the greatest ease of use. Quarantine is one of the most reputable companies in cargo securement and we are proud to see our products being used in sectors such as public transportation, remote exploration and the oil & gas industry.

As transportation and safety compliance standards become more stringent, Quarantine Restraints has developed products that better protect occupants and the public from unsecured cargo. We are proud to play an integral part in helping your company achieve its goal of zero accidents and near misses.

quarantine



Quarantine Restraints firmly secure truck bed cargo. Used in the oil and gas industry, survey and seismic sectors, and for government and military projects.

Carrying Case

Highest Rated Cargo Net in the Industry

- System Includes:** Qr. Exterior Restraint System
- Cargo Net rated 1,967lbs (Working Load Limit) w/carrying case
 - Made of 2" wide seatbelt/poly webbing w/industrial grade stitching
 - Designed connection points to enable proper securement of any sized load
 - 4 specifically designed Detachable Tiedown Straps independantly labeled/rated & suitable for multiple applications

REMOVABLE TIE-DOWNS



Aluminum Climbing Carabiner



Working Load Limit Label



Stamped Rated Hardware



Rated Connection Points



Qr. Interior Restraint System



AVAILABLE CAVITY SETUP

Qr. Interior Restraint System

Designed for safety against backseat cargo becoming projectiles in a sudden stop or accident situation, Interior Restraints are becoming mandatory for worksites.

Safety is our First Priority

- Engineer rated hardware
- Designed to attach to OEM Anchor points
- Quick & simple installation
- Universal attachment for auto interiors

Product No.	Quarantine Products	Description
QABSBN	Qr. Short Box Restraint	73"W x 79"L
QABLBN	Qr. Long Box Restraint	73"W x 99"L
QABSBD	Qr. Short Box Detachable Mesh	73"W x 79"L
QABLBD	Qr. Long Box Detachable Mesh	73"W x 99"L
QABACP	Qr. Accessory Pack	2 Extra Straps w/ hardware
QABIBA	Interior Bar Accessory	Aluminum bar assembly
QABFMA	Floor Mount Anchor	Rated metal connection point
QABSES	Wrap Strap	Soft extension strap
QABCBS	Carabiner 5 Pack	Pack of 5 extra carabiners
QABCBL	Carabiner 10 Pack	Pack of 10 extra carabiners

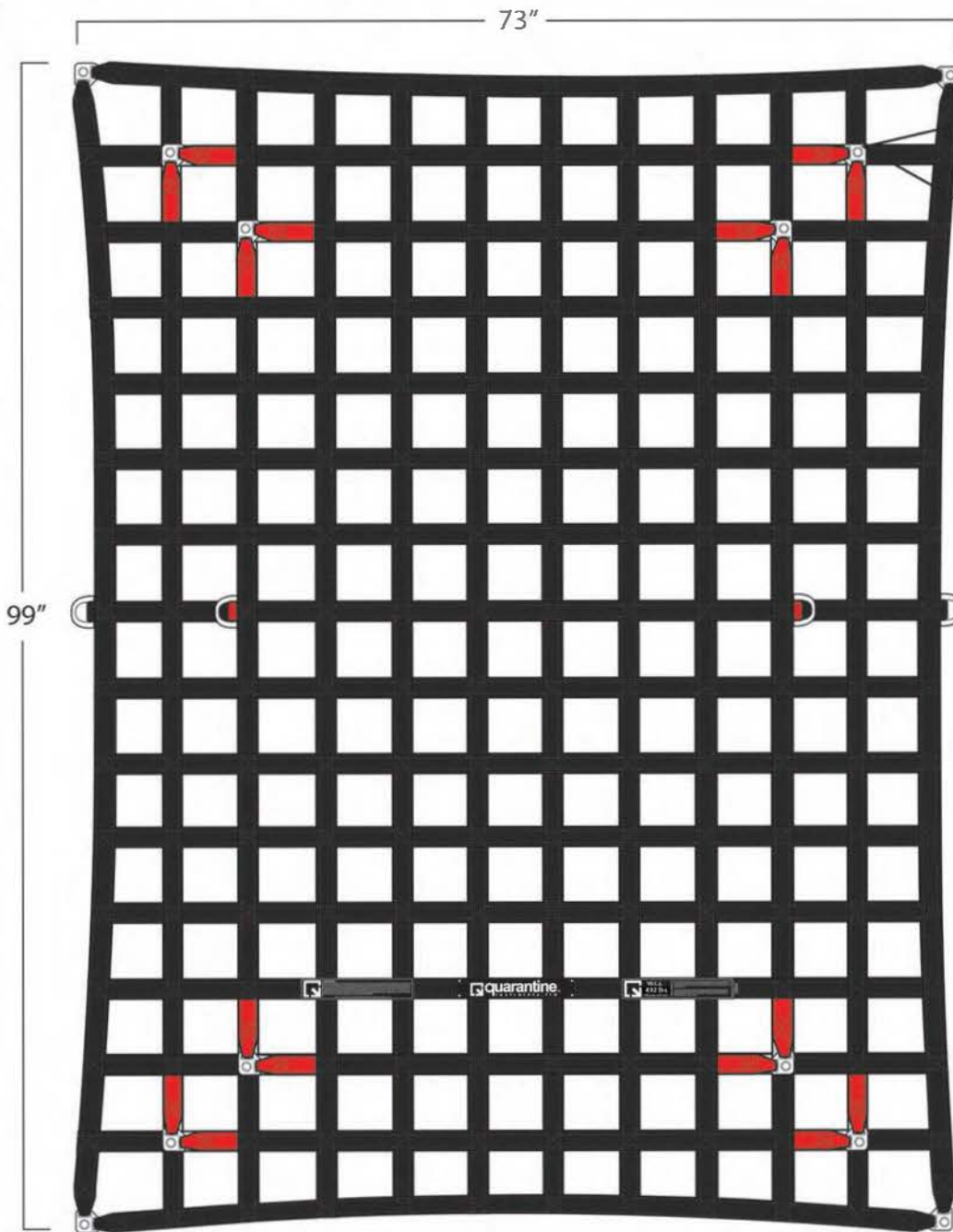

Rated Connection Points



D-Ring Connectors



Aluminum Climbing Carabiner

FS Tie-Down Buckle

Includes:
4 Detachable FS Tie-Down Straps - Max Strap Length 50"



As shown - Long Box Restraint System

	Product	Size	Part #
	Short Box	73" W x 79" L	QAB-SBN
	Long Box	73" W x 99" L	QAB-LBN

Exterior Cargo Restraint System

Highest rated Cargo Net in the Industry



Working Load Limit

Complete Assembly / Sling Load - W.L.L 1,967 lbs
Weakest Component / Tie-Downs - W.L.L 492 lbs

Exterior Restraint System Includes:

- 4 Detachable FS Tie-down Straps suitable for multiple applications
- Connection points to enable proper securement of any sized load
- 2" wide seatbelt/poly webbing w/industrial grade stitching
- Large Carrying Case



Interior Restraint System: 58" W x 60" L (Includes Mesh)
W.L.L 492 lbs (1/3 Break Limit of Weakest Component)
Modular Design & Versatile for application in most vehicle interiors

Quarantine's Interior Safety Divider was developed as a safety divider to provide easy interior cargo separation & securement. Our Interior Restraint System's modular design provides both Secured Setup against your back seat and Cavity Setup for easy access to larger items. The universal attachment allows the net to be installed in most vehicle interiors.



INTERIOR RESTRAINT CAVITY SETUP

Floor Mount Anchor



Product Code: QAB-FMA

NEW

Interior Restraint System

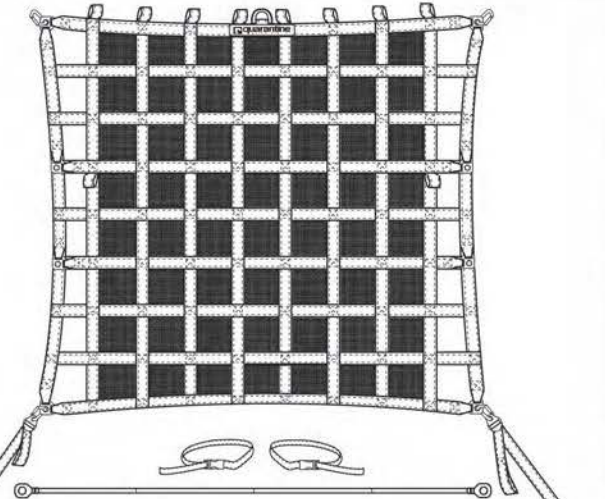

Product Code: QAB-IRN

INTERIOR BAR ACCESSORY PACK CONTENTS

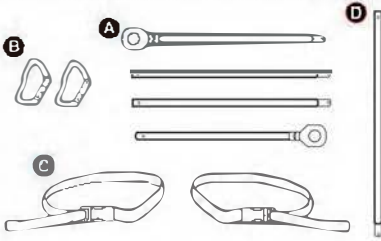

- A** 1 Extension Bar (4 pieces)
- B** 2 Carabiners (Q-Link)
- C** 2 Headrest straps
- D** 1 Extra-length pole section
- Includes Carrying Case

Product Code: QAB-IBA

Rear Extension Bar
(Included with the Interior Net)

QR. Interior Restraint (QAB-IRN)

*Front Extension Bar **A**

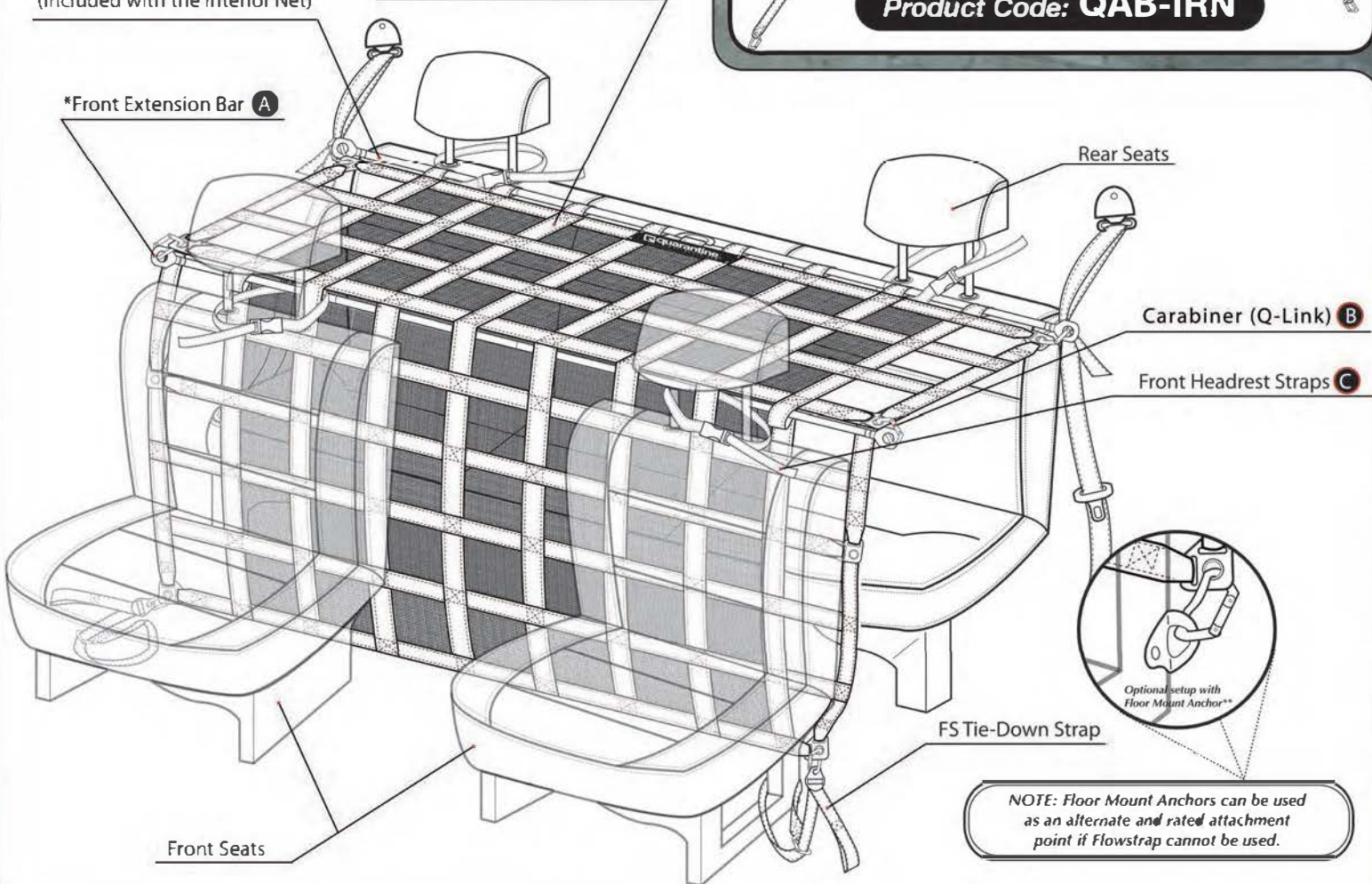

NOTE: Floor Mount Anchors can be used as an alternate and rated attachment point if Flowstrap cannot be used.

* Front extension bar can be purchased separately as a set in the Interior Bar Accessory Pack (QAB-IBA)

** Floor Mount Anchors sold separately (QAB-FMA)

Engineered and Certified
Stamped Rated Hardware

NEW

E QR. Detachable Mesh

Short Box Restraint Mesh Shown
Part Number: **QAB-SBD**

“Designed to attach to the exterior net to restrain small items”

- Team Quarantine

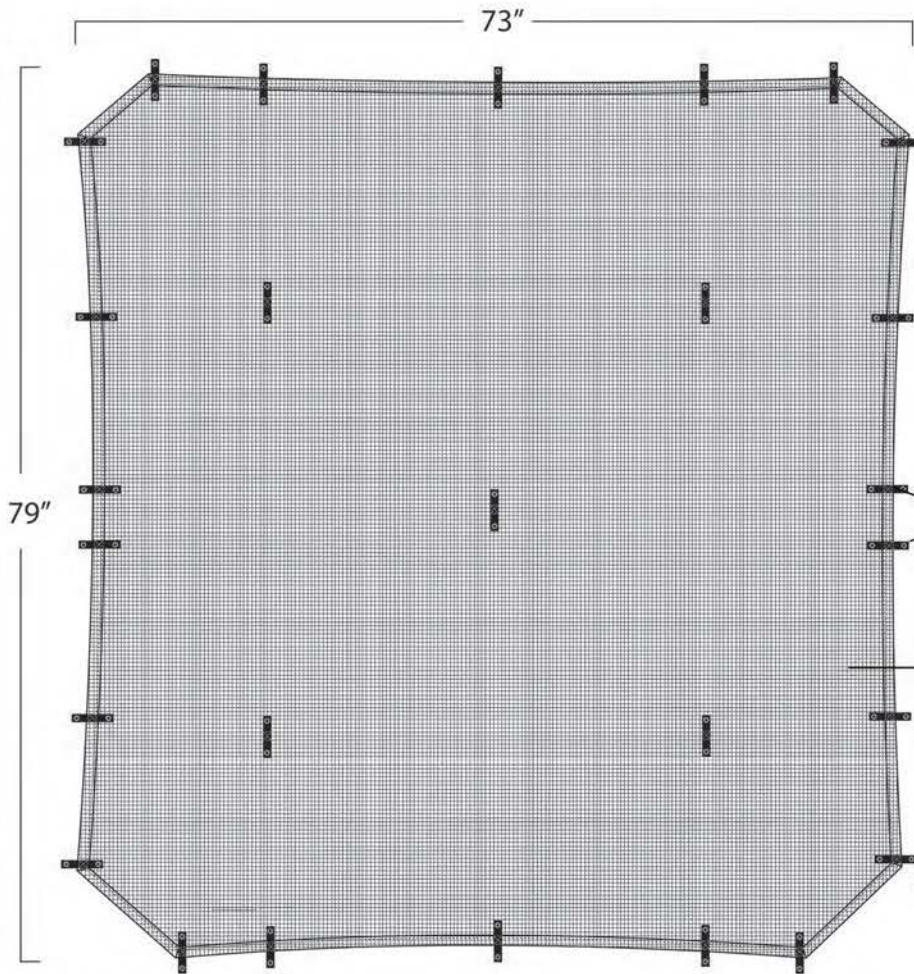

- Mesh Attached to Net

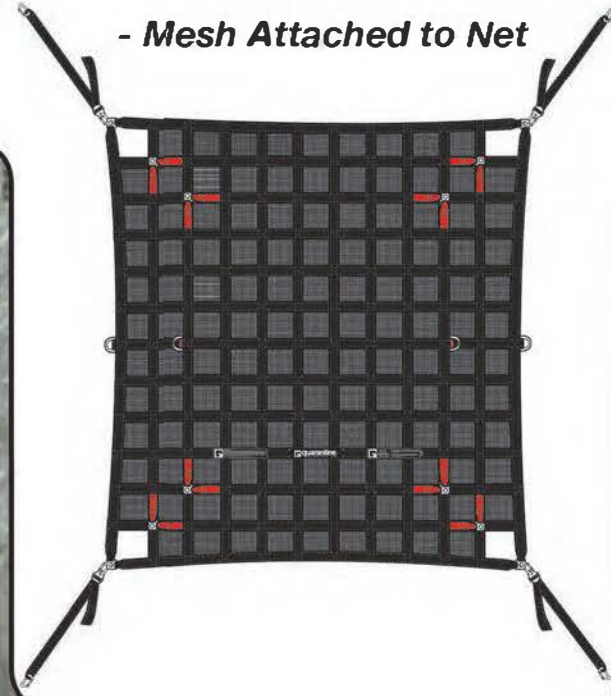

An accessory for Quarantine's Exterior Net, our Detachable Mesh's high-strength polyester webbing will not allow smaller items to dislodge and escape through the net's spacings. It is an excellent solution for when you are carrying a load of various sizes. Available for both the Quarantine Short and Long Restraint Systems.



Product	Size	Part #
Short Mesh	73" W x 79" L	QAB-SBD
Long Mesh	73" W x 99" L	QAB-LBD

Restrain Your Load



Exterior Restraint with Mesh



Large zippered opening for easy access and storage

Easy grip handle for carrying

A QR Storage Case

Extra back zip pocket for accessories

Double lined water-proof protective base

QR Accessory Pack **C**

Multiple storage compartments

Each Quarantine net comes with its own storage case, which offers various compartments and features to make it highly functional. Its wide, zippered opening provides easy access to and storage of your net. Our optional Quarantine Accessory Pack is able to attach securely to your storage case to ensure all parts stay together.

***QR.Case comes with each net purchase and is not sold separately**

B QR Floor Mount Anchor



The Floor Mount Anchor is used as an alternate and a rated attachment point if no connection points exist or extra connection points are wanted. Sold separately.

quarantine™ restraints.ltd	Product	Size	Part #
A	QR Storage Case	17" x 10" x 9"	<i>*Not Sold Separately</i>
B	QR Floor Mount Anchor	2" x 1.5"	QAB-FMA
C	QR Accessory Pack	10" x 6" x 2"	QAB-ACP
D	QR Interior Bar Accessory	22" x 4" x 2.5"	QAB-IBA
E	QR Detachable Mesh	<i>Please see Next Page</i>	<i>Please see Next Page</i>

QR. Accessories

C QR Accessory Pack

Aluminum Climbing Carabiners

Wrap Strap

FS Tie-Down Strap
- Max Length 50"

Sold separately, the Quarantine Accessory Pack contains two extra FS Tie-Down Straps and supplemental connection hardware. Use the arms to attach to the centre anchor points on the net to stabilize high or uneven loads. All six arms attached to a single net ensures you're equipped for every load. The Accessory Pack attaches securely to the QR Storage Case for easy stowage.

D QR Interior Bar Accessory

Front Headrest Straps

Extension Bar

The Interior Bar Accessory contains an extension bar & connection hardware. It is used to create an open cavity in the back seat of the vehicle with the Interior Restraint System by connecting it to the two front seat headrests. Sold separately.

2 in 1 Securement System

Not a traditional Cargo net, it's a full securment system.
Includes 4 Tie down straps that can be used for:
Jobsite equipment • Motorcycles • ATV's etc.

1 Tie-Down Straps

2 Full Cargo Net
(in multiple combinations)

'Wrap Strap' in use with FS Tie-Down
Shown below

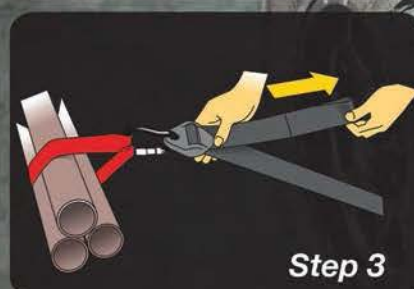
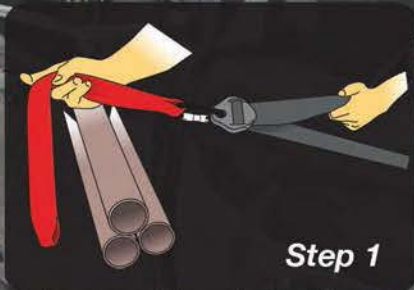

Wrap Strap Tie-Down Extenders



The accessory Wrap Strap (QAB-SES) enables the FS Tie-downs to connect to large anchor/attachment points where a carabiner is unable to connect.

Product	Size	Part #
F Wrap Strap	1" W x 24" L	QAB-SES
Carabiner 5 Pack	2.5" W x 4" L (1.5" Opening)	QAB-CBS
Carabiner 10 Pack	2.5" W x 4" L (1.5" Opening)	QAB-CBL



Utility Trailer & Flat-Deck Double Coverage Net: Size 8.25 ft x 12 ft

By utilizing Quarantine's modular designed cargo net, 2 Long Box Nets connected will create a maximum size net of 8.25ft x 12ft for use on large applications. The combination of nets can also be reduced by overlapping the nets prior to connecting with Carabiners enabling precise installation in all applications.

Components Needed:

- 2 - Long Box Restraints (QAB-LBN)
- 2 - Accessory Packs (QAB-ACP)
- 1 - Carabiner 10 Pack (QAB-CBL)



Connect with Carabiners

2

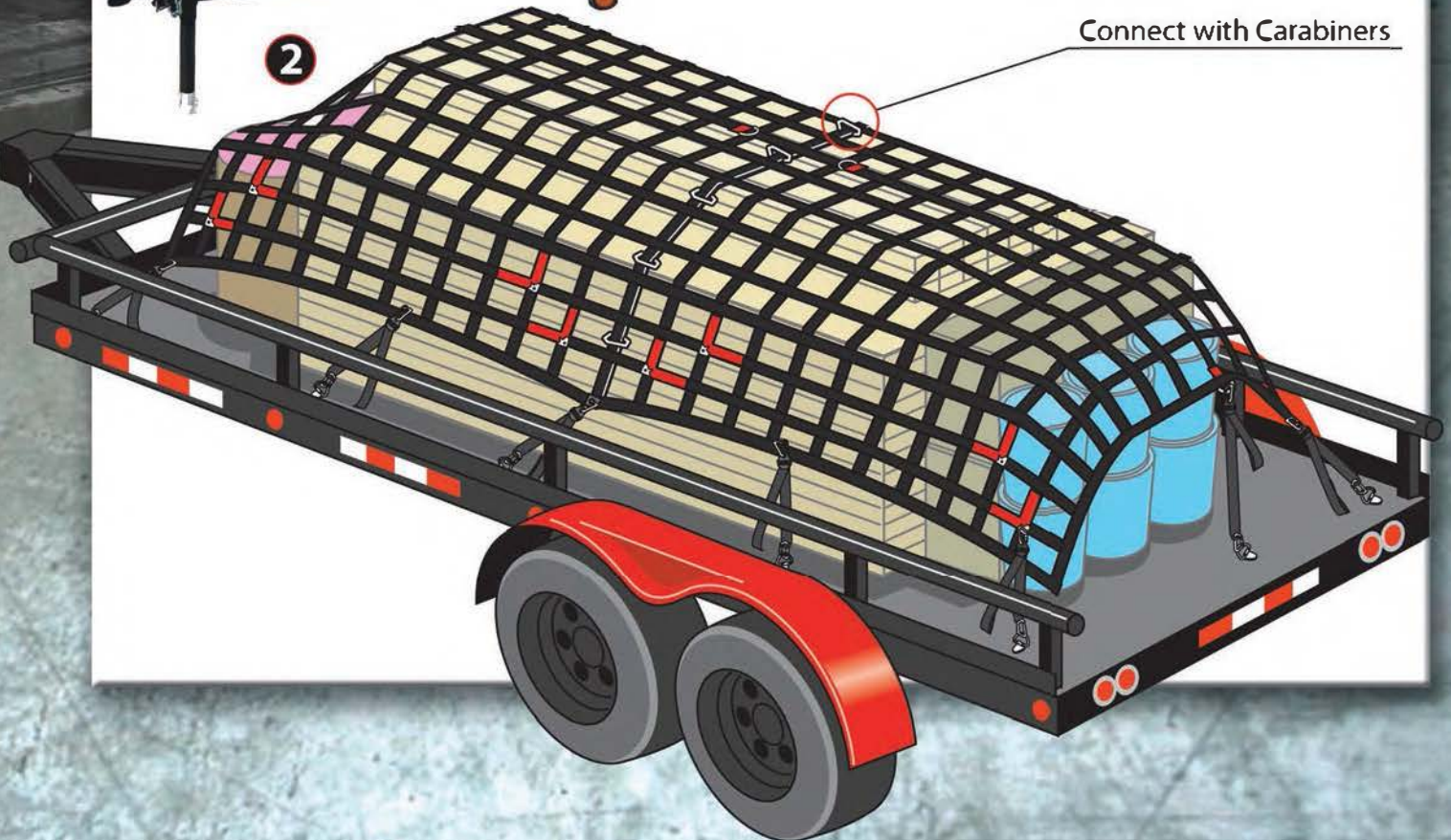



Certified Load Ratings



- Weakest Component Break Test**
(1/3rd Break Limit of Weakest Component)

$$1,475 \text{ lbs} \div 3 = \text{W.L.L } 492 \text{ lbs}$$

- Complete Assembly Break Test**
(1/3rd Break Limit of Complete Assembly)

$$5,904 \text{ lbs} \div 3 = \text{W.L.L } 1,967 \text{ lbs}$$

Quarantine does not recommend to exceed 450 lbs for vehicle application

Weakest Component Break Test

Test conducted by using a calibrated hydraulic ram to break each component systematically in a controlled environment



Complete Assembly Break Test

Test conducted by stressing all components equally until failure point / break limit is determined on complete assembly

Technical Information

Working Load Limit

Product	Part #	Dimensions	Strap Length	Weakest Component Test	Complete Assembly Test
Long Box Restraint	QRT-LBN	99" X 73"	50"	W.L.L 492 lbs	W.L.L 1,967 lbs
Short Box Restraint	QRT-SBN	79" X 73"	50"	W.L.L 492 lbs	W.L.L 1,967 lbs
Interior Restraint	QRT-IRN	60" X 58"	40"	W.L.L 492 lbs	W.L.L 1,967 lbs

Hardware and Components

	Content	Break Strength
Webbing	Polyester	6,800 lbs
Carabiner	Aluminum	3,100 lbs
FS Tie-Down Buckle	POM DuPont Nylon	1,925 lbs
Mid D-Ring	POM DuPont Nylon	1,889 lbs
Corner C-Ring	POM DuPont Nylon	1,475 lbs

All hardware components of the Quarantine Restraints System are stamped and labeled with Working Load Limits (W.L.L) to ensure our customers the highest level of confidence in our products. All products are DOT (Department of Transportation) compliant and meet NACSS (North American Cargo Securement Standard) requirements. We are on the forefront of current and future safety regulations.

Component Break Strength

As Shown - Short Box Restraint System

FS Tie-Down Buckle - 1,925 lbs

Mid D-Ring - 1,889 lbs

Webbing - 6,800 lbs

Corner C-Ring - 1,475 lbs

Carabiner - 3,100 lbs

"The net is only as strong as its weakest link"

- Team Quarantine

