



## INSTALLATION INSTRUCTIONS

QA1 P/N 52896 Front Sway bar

'63-'86 Chevrolet/GMC C Series Pickup, '87-91 Chevrolet/GMC R Series Pickup

READ ALL INSTRUCTIONS CAREFULLY AND THOROUGHLY PRIOR TO STARTING INSTALLATION. PRODUCTS THAT HAVE BEEN INSTALLED ARE NOT ELIGIBLE FOR RETURN. USE THE PROPER JACKING LOCATIONS. DEATH OR SERIOUS INJURY CAN RESULT IF INSTRUCTIONS ARE NOT CORRECTLY FOLLOWED. A GOOD CHASSIS MANUAL, AVAILABLE AT YOUR LOCAL PARTS STORE, MAY ALSO AID IN YOUR INSTALLATION.

### • DISCLAIMER / WARRANTY •

QA1 WARRANTS THAT THE PRODUCTS WILL BE FREE FROM DEFECTS IN MATERIAL AND WORKMANSHIP FOR ONE YEAR FROM DATE OF SALE TO THE ORIGINAL PURCHASER. QA1 MAKES NO OTHER WARRANTY OF ANY KIND, EXPRESS OR IMPLIED. QA1 SHALL HAVE NO OBLIGATION UNDER THE FOREGOING WARRANTY WHERE THE DEFECT IS THE RESULT OF IMPROPER OR ABNORMAL USE, YOUR NEGLIGENCE, VEHICLE ACCIDENT, IMPROPER OR INCORRECT INSTALLATION OR MAINTENANCE, NOR WHEN THE PRODUCT HAS BEEN REPAIRED OR ALTERED IN ANY WAY. QA1'S LIABILITY IN THE CASE OF DEFECTIVE PRODUCTS SUBJECT TO THE FOREGOING WARRANTY SHALL BE LIMITED TO THE REPAIR OR REPLACEMENT, AT QA1'S OPTION, OF THE DEFECTIVE PRODUCTS.

THE USER UNDERSTANDS AND RECOGNIZES THAT RACING PARTS, SPECIALIZED STREET ROD EQUIPMENT, AND ALL PARTS AND SERVICES SOLD BY QA1 ARE EXPOSED TO MANY AND VARIED CONDITIONS DUE TO THE MANNER IN WHICH THEY ARE INSTALLED AND USED. QA1 SHALL BEAR NO LIABILITY FOR ANY LOSS, DAMAGE OR INJURY, EITHER TO A PERSON OR TO PROPERTY, RESULTING FROM THE INSTALLATION, DIRECT OR INDIRECT USE OF ANY QA1 PRODUCTS OR INABILITY BY THE BUYER TO DETERMINE PROPER USE OR APPLICATION OF QA1 PRODUCTS. WITH THE EXCEPTION OF THE LIMITED LIABILITY WARRANTY SET FORTH ABOVE, QA1 SHALL NOT BE LIABLE FOR ANY CLAIMS, DEMANDS, INJURIES, DAMAGES, ACTIONS, OR CAUSES OF ACTION WHATSOEVER TO BUYER ARISING OUT OF OR CONNECTED WITH THE USE OF ANY QA1 PRODUCTS. MOTORSPORTS ARE DANGEROUS; AS SUCH, NO WARRANTY OR REPRESENTATION IS MADE AS TO THE PRODUCT'S ABILITY TO PROTECT THE USER FROM INJURY OR DEATH. THE USER ASSUMES THAT RISK!

### TOOLS AND SUPPLIES REQUIRED

- Floor Jack
- Jack Stands
- Blue Thread Locker
- Wrench Set
- Ratchet & Socket Set
- Drill with 3/8" bit
- Grinder and/or Air Chisel

### Pre-Installation Note

Part number 52896 requires the removal of the factory front sway bar frame brackets and the installation of the supplied QA1 sway bar brackets. '63-'72 trucks not originally equipped with a sway bar will require the removal of two cross member rivets. A grinder and punch or air chisel is recommended for removal.

### Installation Instructions

1. Raise the vehicle and support with jack stands on a stable surface.
2. Unbolt and remove the OEM sway bar if equipped.

**Caution: Sway bars are heavy steel parts that can cause injury if unsupported during removal or installation.**

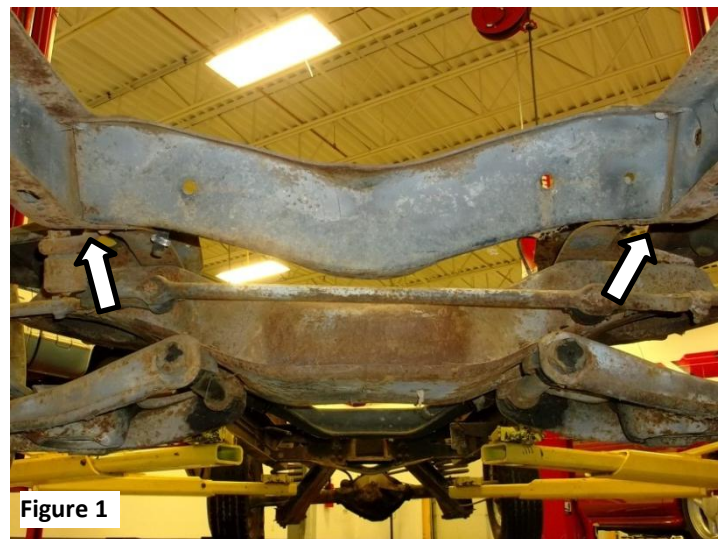
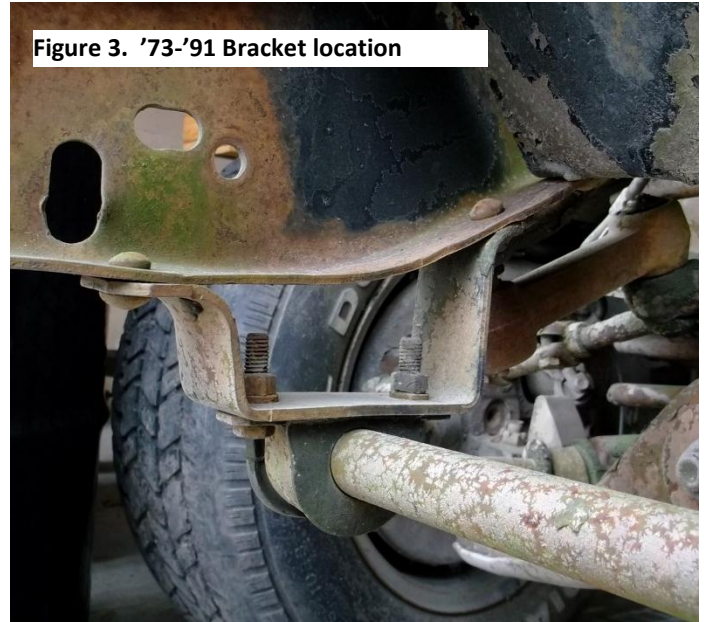
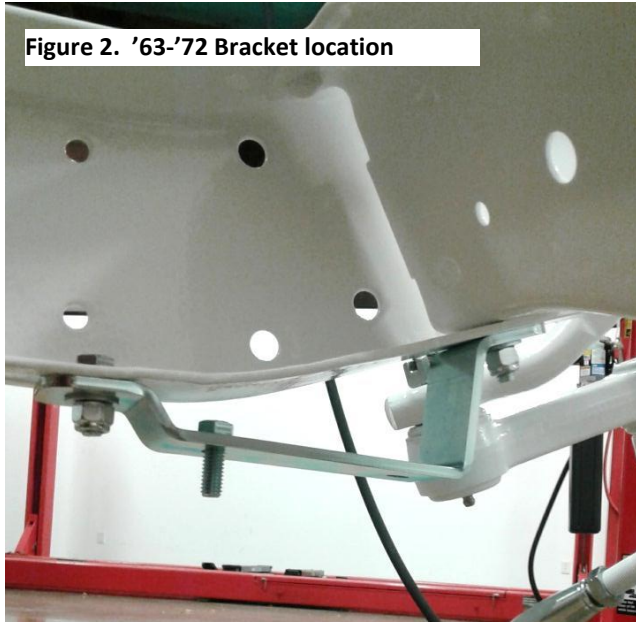

Figure 1

3. For '63-'72 trucks not originally equipped with a front sway bar remove the bottom rivets in the frame cross member. See **Figure 1**.
4. If originally equipped with a front sway bar, remove the rivets from the factory frame mounts. See **Figure 2**.
5. 1973 and later trucks not originally equipped with a sway bar will have the holes in the frame already and the QA1 frame brackets will bolt on using those holes. The factory brackets will need to be replaced with QA1 brackets for trucks originally equipped with a front sway bar. See **Figure 3**.



6. Use the supplied hardware to install the QA1 sway bar brackets to the frame and torque to 30 lb.-ft. The 3/8" x 1 1/4" bolts should be used for the cross member location for '63-'72 Trucks. **Note:** It is best to install the sway bar mounting bolts in the brackets before the brackets are installed on the frame. See **Figure 2**.
7. Grease and install the bushings on the QA1 sway bar and mount to the new frame brackets. Torque to 30 lb.-ft.
8. Assemble the sway bar end links as shown in **Figure 4**. **Note:** The double ended stud (#8) and rod ends are right hand thread and thread locker should be applied **only** to the side of the stud without the jam nut.
9. If the vehicle is using QA1 control arms, attach the sway bar end links to the control arm using the supplied hardware and spacers. The wider SG8-67 spacers are used at the control arm mount. See **Figure 5**.

10. If the vehicle is using stock control arms, attach the end links to the sway bar. Install the included control arm mount brackets and lower the vehicle to ride height. **Figure 4**
11. Install the top bolt through the existing bolt hole in the lower control arm and position the bracket so the end links are vertical with the truck sitting at ride height. See **Figure 6**.
12. Mark the remaining hole location on the lower control arm and move the mounting bracket out of the way.
13. Using a 3/8" drill bit, drill the hole in the lower control arm and mount the bracket with the 7/8" long bolt and thin nut in the vertical position.

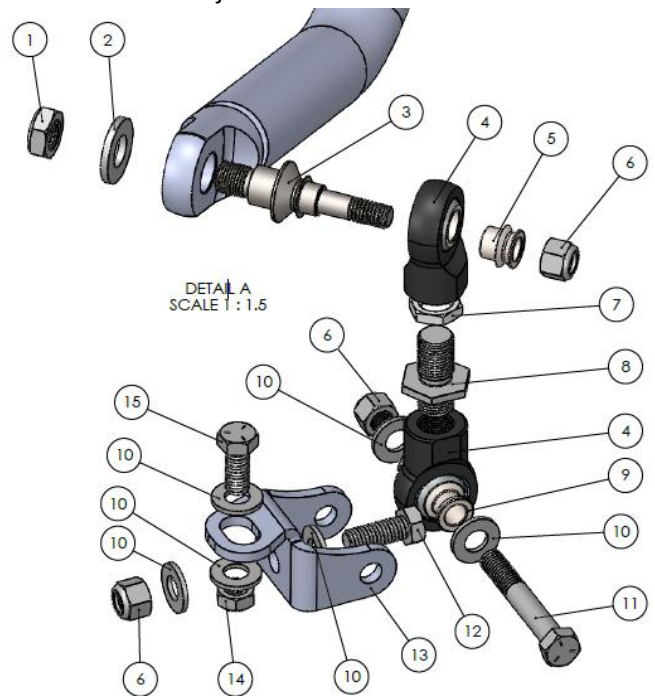

**Figure 5, Right Side Shown**

Rev. 01292018

14. Repeat steps 10-13 on the other side of the vehicle.

15. Re-install the end links and tighten the bolts to 30 lb.-ft. **NOTE: DO NOT OVER-TIGHTEN THE BOLTS!** Over-tightening can deform the spacers causing the bolts to stick in the spacers.

16. Tighten sway bar bracket bolts and bushing bolts.

Figure 5, Right Side shown



Figure 6, Right Side Shown



Balloon #	Item #	DESCRIPTION	QTY.	Balloon #	Item #	DESCRIPTION	QTY.
1		NUT, NYLOCK JAM, 1/2-20 LH, YELLOW	2	11		BOLT, 3/8-16 X 2.5" RH	2
2		WASHER, 1/2 SAE	2	12		BOLT, 3/8-16 X 1.0" RH	8
3	9029-309	HIGH MISALIGNMENT STUD	2	13	9037-594	BRACKET, STOCK LCA, RIGHT SIDE	1
4	AFR8-901	ROD END, 1/2" X 9/16-18	4	14		NUT, NYLOCK JAM, 3/8-16 RH	2
5	SG8-64	HIGH MIS SPACER, SS	2	15		BOLT, 3/8-16 X 0.875 RH	2
6		NUT, NULOCK, 3/8-16 RH	6		9037-584	SWAY BAR FRONT, 1 3/8"	1
7	9014-113	NUT, JAM 9/16-18 RH	2		9037-593	BRACKET, CHASSIS TO FRONT SWAY BAR	2
8	9037-596	LINKAGE FASTNER, MALE TO MALE	2		9037-595	BRACKET, STOCK LCA, LEFT SIDE	1
9	SG8-67	HIGH MIS SPACER, SS	4		9032-170	BUSHING, SWAY BAR FRAME MOUNT 1-3/8"	2
10		WASHER, 3/8" SAE	20			BOLT, 3/8-16 X 1.25" RH	2
11		BOLT, 3/8-16 X 2.5" RH	2				