



### INSTALLATION INSTRUCTIONS

QA1 P/N 52866 Rear Sway bar for QA1 Suspension System  
'65-'72 Ford F100

### TOOLS AND SUPPLIES REQUIRED

- Floor Jack
- Jack Stands
- SAE Wrench Set
- SAE Ratchet & Socket Set

1. Jack the rear of the truck up and securely place on jack stands.
2. Mount one Inner Frame Bracket on driver and passenger side with the shared mounting holes of the frame notch bracket using 7/16" bolts, washers, and nylock nuts. Mount bracket forward and mounting bolts towards rear for both driver and passenger side. Torque to 49 lb. ft.  
**(Figure 1 & 2)**

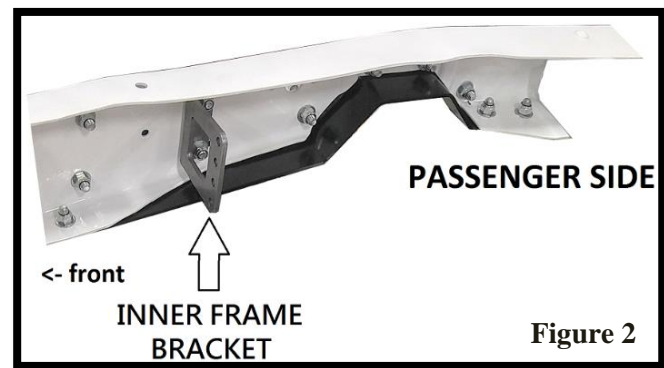
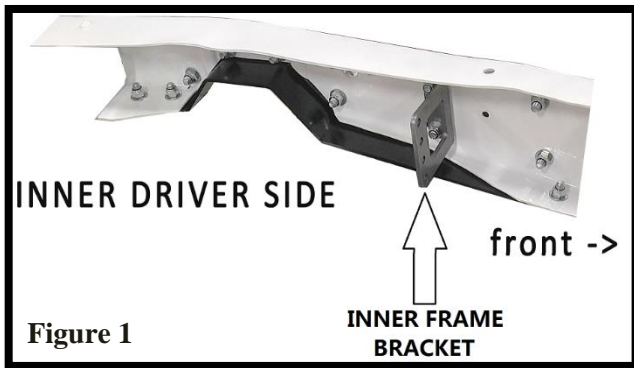

3. Install bushings and chassis mounts onto sway bar. **(Figure 3)**
4. Mount the sway bar chassis mounts to the axle using the included axle u-bolts, 1/2" washers, and 1/2" nuts. Evenly space sway bar to frame mounts. Torque to 70 ft. lb. **(Figure 4 & 5)**

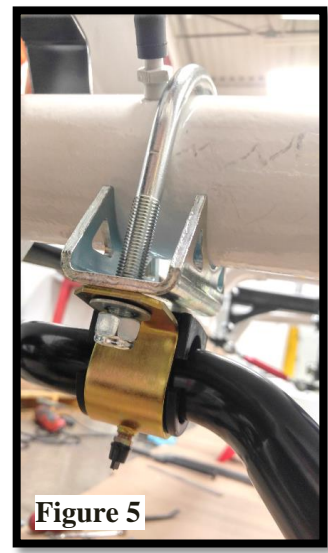

**INSTALL NOTE:**

Brake line junction on the axle may need to be spaced off the axle as to not interfere with driver side axle u-bolt. **(Figure 6)**

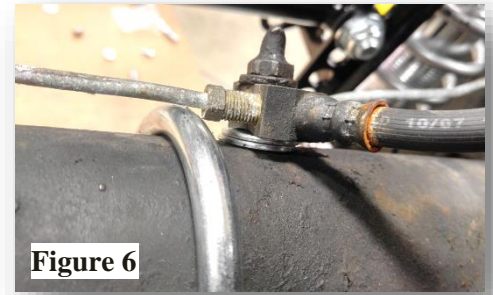

5. Install 1/2" right hand thread jam nuts onto right hand thread rod ends and thread into anodized red adjustment sleeve. Do the same on the left hand thread side of the adjuster sleeve with left hand thread jam nut on left hand thread rod end. Thread rod ends all the way into the adjustment sleeve. **(Figure 7)**



6. Attach one end of the assembled sleeve to the frame mount using two high misalignment spacers installed into the rod end. Fasten to frame mount using 3/8" x 2.5" bolts, with washer on the nylock nut side of the mount. The sway bar link will mount to the rear of the mount in the third hole from the top as a starting point. Torque to 31 lb. ft. **(Figure 8)**



7. Attach sway bar to adjuster link using specialty high misalignment stud with 1/2" washer and nylock nut on the sway bar side. Attach link side using high misalignment spacer and a 3/8" nylock nut. Torque connection to 31 lb. ft. **(Figure 9)**

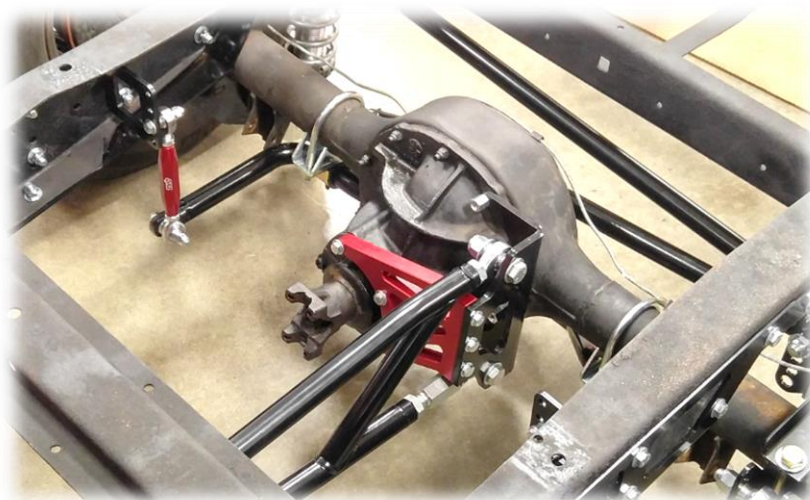

8. At ride height, adjust end links so that the sway bar is parallel with the ground. Tighten jam nuts to complete the install.
9. Grease zerck fittings with 2-3 pumps of marine grease for bushing connections.

BALLOON #	ITEM #	DESCRIPTION	QTY.
1	9033-459	SLEEVE, .875"HEX ALUMINUM ANODIZED	2
2	9037-628	BRACKET, AXLE SADDLE MOUNT, 3 INCH	2
3	9037-677	SWAY BAR, REAR 1 1/4", BLACK	1
4	9037-701	PLATE, SWAY BAR MOUNT	2
5	7039-228	HARDWARE KIT, REAR SWAY BAR	1
6	XMR8	ROD END (X) ENDURA ALLOY HT	2
7	JNR8S	Jam Nut, Right Hand Thread	2
8	XML8	ROD END (X) ENDURA ALLOY HT	2
9	JNR8S	Jam Nut, Left Hand Thread	2
10	SG8-64	High Misalignment Spacer, SS	6
11	9029-309	HIGH MISALIGNMENT STUD	2
12	9012-204	U-BOLT, 7/16-20 X 3.125" X 4.5"	2
13	9032-171	BUSHING, SWAY BAR FRAME MOUNT 1-1/4"	2

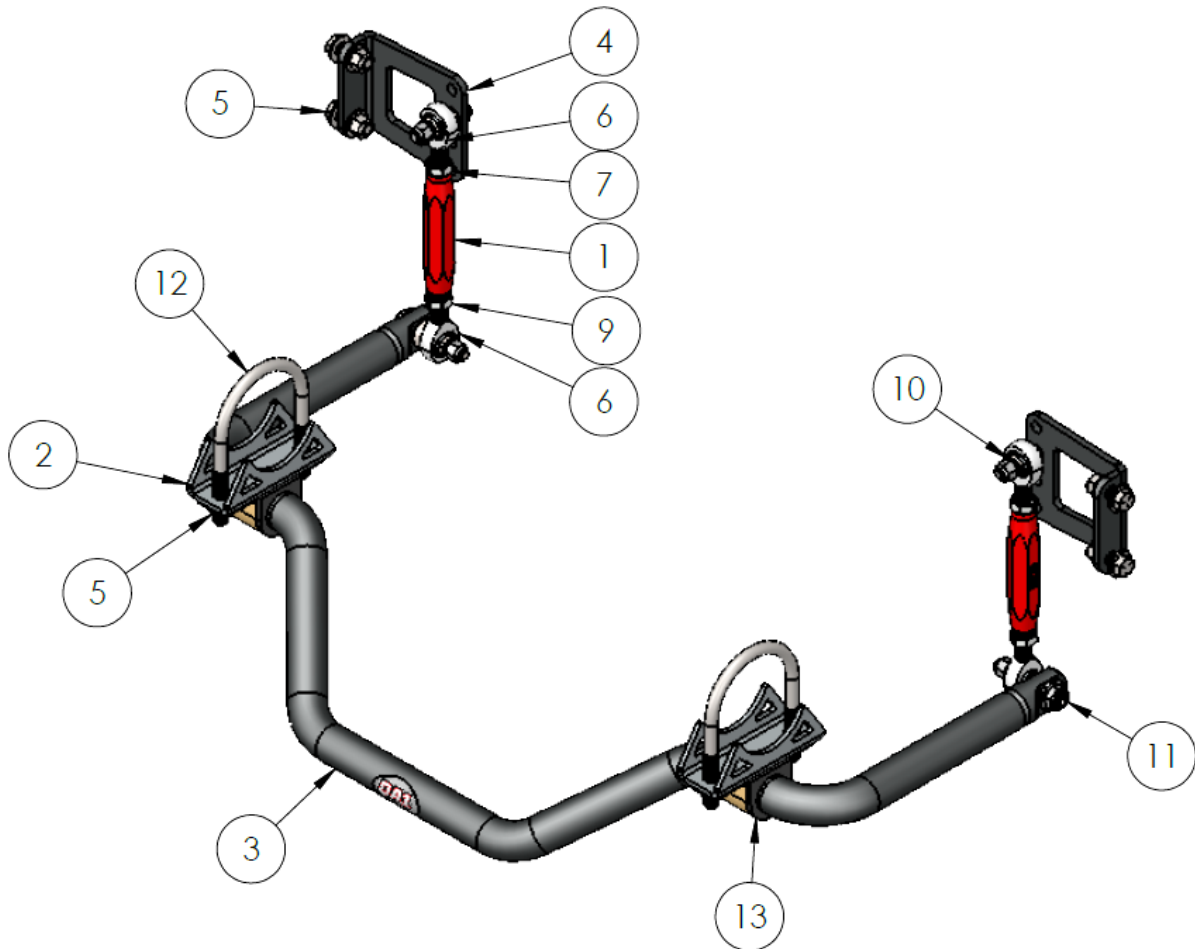

HARDWARE KIT, REAR SWAY BAR, 67-72 FORD F100	
1st Description	Qty.
BOLT, 3/8-16 X 2.5"	2
NUT, NYLOCK, 3/8-16	2
WASHER, SAE, 3/8	2
BOLT, 7/16-14 X 1.25"	4
NUT, NYLOCK, 7/16-14	4
WASHER, SAE, 7/16	12
WASHER, SAE, 1/2	2
NUT, NYLOCK, THIN JAM, 1/2-20	2