

QA1

INSTALLATION INSTRUCTIONS

QA1 P/N 52824 Front Sway Bar for QA1 Lower Control Arms
'65-'70 Chevrolet Impala, Caprice, Belair, Biscayne

TOOLS AND SUPPLIES REQUIRED

- Floor Jack
- Jack Stands
- Drill
- Crescent Wrench
- Two Clamps
- 3/8" Drill Bit
- SAE Socket Set

PRE INSTALLATION NOTES:

This sway bar is designed to work with QA1 Lower Control Arms and **WILL NOT WORK** with factory control arms. If using the factory control arms, use sway bar part number 52823.

DISASSEMBLY:

1. Raise the vehicle and support with jack stands on a stable surface.
2. Remove the driver side wheel to make room for the factory sway bar to be removed.
3. Remove the sway bar end links from both sides of the sway bar.
4. Remove the sway bar frame mounts by removing the bolts and inner frame nuts. **(Figure 1)**
5. Remove the driver side strut rod from the lower control arm. Removing this connection will allow the sway bar to be removed. **(Figure 2)**
6. Remove the sway bar by sliding the passenger side of the sway bar through the passenger side frame hole, then the drivers side frame hole. **(Figure 3)**
7. Refer to the instructions included with the QA1 lower control arms for arm removal and installation.



PRE-INSTALLATION NOTE:

This front sway bar uses a base plate mounted to the frame before the sway bar is mounted.

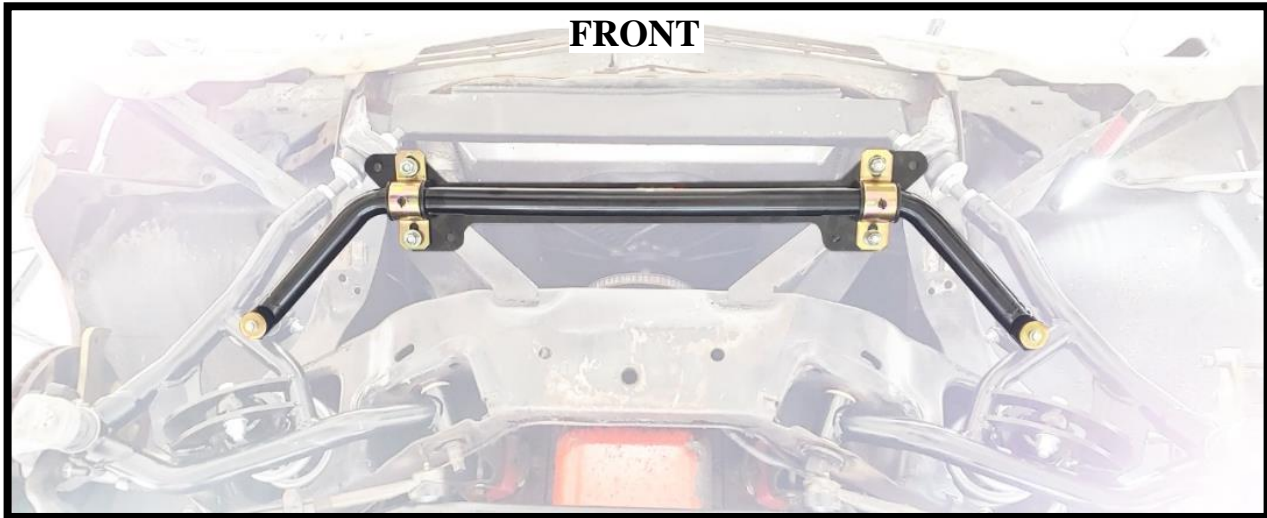

INSTALLATION:

1. Using a crescent wrench, slightly bend the frame rail up where the base plate will mount. Bend the frame up so that both lower frame rails will mount the base plate completely flat. **(Figure 5)** Because of the slight angle of the lower frame lip, failure to follow this step will allow the base plate to contact the installed sway bar.
2. Position the sway bar base onto the frame with the wide end of the base facing forward. Clamp the sway bar base to the frame with the back edge of the base plate 3-5/8" from the front crossmember. **(Figure 4)** The outermost and innermost holes of the sway bar base should land in the center of the diagonal frame rail. Adjust side to side if the holes do not land on the diagonal frame rails.
3. Mark the outermost holes of the front of the base plate and the innermost holes of the rear of the base plate onto the frame rails.
4. Remove the sway bar base plate and drill the marked holes using a 3/8" drill bit.

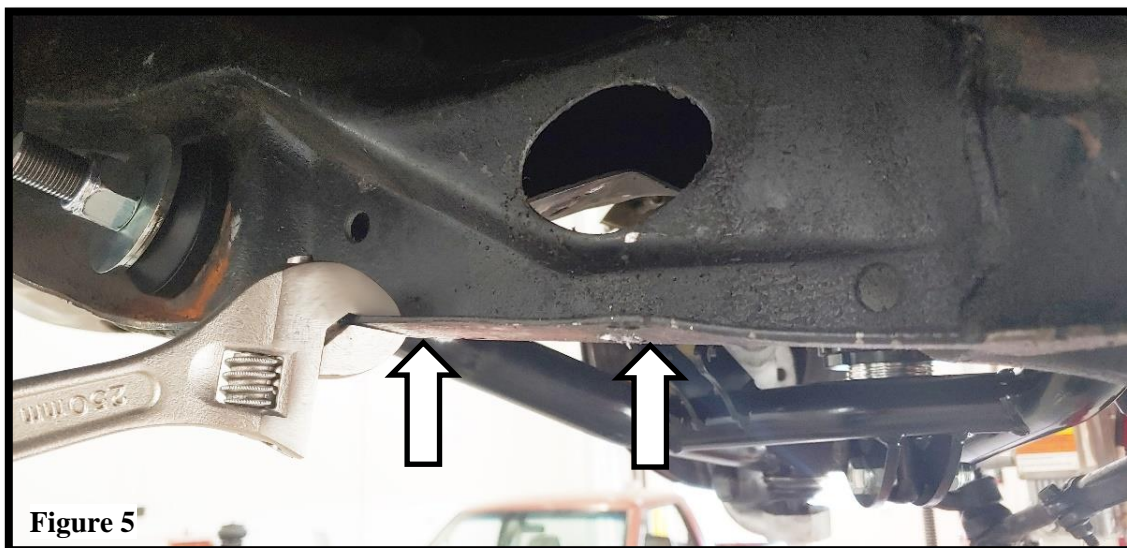

5. Install the base plate to the frame using the included 3/8" x 1" hardware with two washers per connection and nylock nut. **(Figure 6)** Torque to 31 lb. ft



6. Mount the sway bar (centered) to the base plate using the included frame mounts and 3/8" x 1" hardware. Two washers and nylock nut will be used on each connection. **(Figure 7)** Torque to 31 lb. ft.

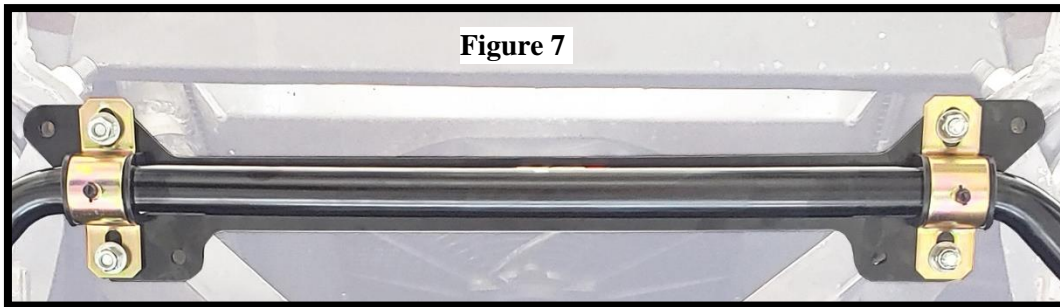

BALLOON #	PART NUMBER	DESCRIPTION	QTY
1	9029-357	STUD, SWAY BAR MOUNT	2
2	XFR8	ROD END, ENDURA ALLOY	2
3	9005-270	WASHER, SWAY BAR BUSHING	4
4	-	WASHER, SAE, 3/8"	4
5	SG8-64	HIGH MISALIGNMENT SPACER, .5" O.D.	4
6	9032-349	BUSHING, SWAY BAR END LINK	4
7	-	NUT, NYLOCK, 3/8"-16	4
8	-	BOLT, HEX, 3/8"-16 x 2"	2

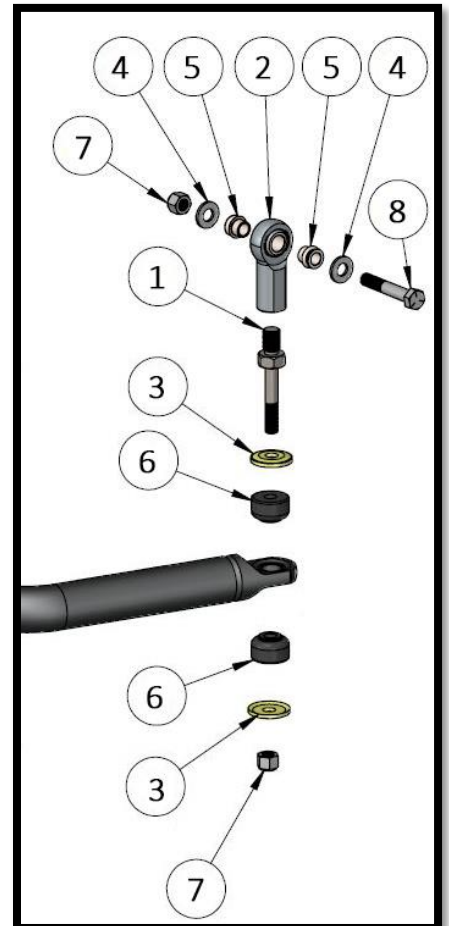

7. Install the end link stud (#1) into the Endura Series rod end (#2). Torque to 40 lb. ft.
8. Install two high misalignment spacers (#5) into each side of the rod end bore.
9. Connect the rod end to the control arm using 3/8" x 2" bolt (#8) with two washers (#4) and nylock nut (#7). Torque to 31 lb. ft.
10. Connect the sway bar to the end link using one washer (#3) and bushing (#6) on the top and bottom of the sway bar. Secure with the 3/8" nylock nut (#7). Torque to 31 lb. ft.
11. Re-install the driver side strut rod and wheel before lowering the car from the jack stands.

QA1



READ ALL INSTRUCTIONS CAREFULLY AND THOROUGHLY PRIOR TO STARTING INSTALLATION. PRODUCTS THAT HAVE BEEN INSTALLED ARE NOT ELIGIBLE FOR RETURN. USE THE PROPER JACKING LOCATIONS. DEATH OR SERIOUS INJURY CAN RESULT IF INSTRUCTIONS ARE NOT CORRECTLY FOLLOWED. A GOOD CHASSIS MANUAL, AVAILABLE AT YOUR LOCAL PARTS STORE, MAY ALSO AID IN YOUR INSTALLATION.

[Learn more about performance suspension parts we have.](#)