



### **ASSEMBLY INSTRUCTIONS**

QA1 p/n RCK52327, RCK52328, RCK52329, RCK52331, RCK52332, RCK52333, RK101K  
1982-2002 F-body bolt-in [Rear Coil-Over Conversion Kit](#)

READ ALL INSTRUCTIONS CAREFULLY AND THOROUGHLY PRIOR TO STARTING INSTALLATION. PRODUCTS THAT HAVE BEEN INSTALLED ARE NOT ELIGIBLE FOR RETURN. USE THE PROPER JACKING LOCATIONS. DEATH OR SERIOUS INJURY CAN RESULT IF INSTRUCTIONS ARE NOT CORRECTLY FOLLOWED. A GOOD CHASSIS MANUAL, AVAILABLE AT YOUR LOCAL PARTS STORE, MAY ALSO AID IN YOUR INSTALLATION.

#### **• DISCLAIMER / WARRANTY •**

QA1 WARRANTS THAT THE PRODUCTS WILL BE FREE FROM DEFECTS IN MATERIAL AND WORKMANSHIP FOR ONE YEAR FROM DATE OF SALE TO THE ORIGINAL PURCHASER. QA1 MAKES NO OTHER WARRANTY OF ANY KIND, EXPRESS OR IMPLIED. QA1 SHALL HAVE NO OBLIGATION UNDER THE FOREGOING WARRANTY WHERE THE DEFECT IS THE RESULT OF IMPROPER OR ABNORMAL USE, YOUR NEGLIGENCE, VEHICLE ACCIDENT, IMPROPER OR INCORRECT INSTALLATION OR MAINTENANCE, NOR WHEN THE PRODUCT HAS BEEN REPAIRED OR ALTERED IN ANY WAY. QA1'S LIABILITY IN THE CASE OF DEFECTIVE PRODUCTS SUBJECT TO THE FOREGOING WARRANTY SHALL BE LIMITED TO THE REPAIR OR REPLACEMENT, AT QA1'S OPTION, OF THE DEFECTIVE PRODUCTS.

THE USER UNDERSTANDS AND RECOGNIZES THAT RACING PARTS, SPECIALIZED STREET ROD EQUIPMENT, AND ALL PARTS AND SERVICES SOLD BY QA1 ARE EXPOSED TO MANY AND VARIED CONDITIONS DUE TO THE MANNER IN WHICH THEY ARE INSTALLED AND USED. QA1 SHALL BEAR NO LIABILITY FOR ANY LOSS, DAMAGE OR INJURY, EITHER TO A PERSON OR TO PROPERTY, RESULTING FROM THE INSTALLATION, DIRECT OR INDIRECT USE OF ANY QA1 PRODUCTS OR INABILITY BY THE BUYER TO DETERMINE PROPER USE OR APPLICATION OF QA1 PRODUCTS. WITH THE EXCEPTION OF THE LIMITED LIABILITY WARRANTY SET FORTH ABOVE, QA1 SHALL NOT BE LIABLE FOR ANY CLAIMS, DEMANDS, INJURIES, DAMAGES, ACTIONS, OR CAUSES OF ACTION WHATSOEVER TO BUYER ARISING OUT OF OR CONNECTED WITH THE USE OF ANY QA1 PRODUCTS. MOTORSPORTS ARE DANGEROUS; AS SUCH, NO WARRANTY OR REPRESENTATION IS MADE AS TO THE PRODUCT'S ABILITY TO PROTECT THE USER FROM INJURY OR DEATH. THE USER ASSUMES THAT RISK!

### **DO NOT VOID YOUR WARRANTY!**

FAILURE TO LUBRICATE THE COIL OVER THREADS WITH **PERMATEX® ANTI-SEIZE LUBRICANT** PRIOR TO ADJUSTING RIDE HEIGHT WILL CAUSE DAMAGE TO YOUR SHOCK ABSORBER THUS VOIDING THE WARRANTY. ALL RIDE HEIGHT ADJUSTMENTS MUST BE MADE WITH THE VEHICLE'S WEIGHT COMPLETELY UNLOADED FROM THE SUSPENSION

### **TOOLS AND SUPPLIES REQUIRED**

- Floor Jack
- Jack Stands
- Tire Chocks
- Torque Wrench
- Common Hand Tools
- Drill

### **KIT CONTAINS**

- Two Proma Star® Shocks
- Two Springs
- Mounting Brackets
- All Necessary Hardware

### **Removal**

1. Follow the factory service information to remove rear shock absorbers and coil springs.

### **Coil-Over Shock Assembly**

1. Fully extend the piston rod and then screw the aluminum lock nut (shoulder up) and the spring seat adjuster nut (shoulder up) down to the last thread - NO FURTHER. Now is a good time to lubricate the threads of the shock body with **Permatex® Anti-Seize Lubricant**.
2. QA1 highly recommends using the QA1 thrust bearing kit (part #7888-110) for ease of adjustment. If the thrust bearing kit is used, coat both washers with **Permatex® Anti-Seize Lubricant**. Install the stainless steel spring seat washer, then

the bearing, then the second washer. If the thrust bearing kit is not used, coat the stainless steel spring seat washer with **Permatex® Anti-Seize Lubricant**.

- Place the lubricated side of the washer down on the spring seat. Slide the spring over the shock body and down onto the spring seat. Slip the spring cap in place, making sure that it is set in the spring squarely.
- Adjust the spring seat up until the spring is slightly compressed. This ensures that the spring cap, spring and spring seat washer remain in place and aligned.
- Install the upper coil-over brackets on the upper poly bushing of the shock with the ½ in. X 2-1/2 in. bolt and Nylock nut. Tighten the bolt and nut to 50 ft. lbs.

### **Installation**

- Mount the lower brackets onto the vehicle in place of the factory brackets. Install the 9/16 in. washer and Nylock nut. The bracket will mount perpendicular to the axle tube.
- A second anchoring bolt is supplied for bracing. This bolt will be installed in the hole in the QA1 bracket just above the primary mounting bolt. Mark this hole with a marker/punch to reference the spot to be drilled.
- Remove the lower shock mount bracket and drill a 3/8 in. hole in the spot marked in step 2.
- After the hole has been drilled, re-install the lower shock mount bracket and torque the mounting studs to 50 ft. lbs.
- Install the supplied 3/8 X 1.5 in. bolt in the top hole, it may be necessary to enlarge the upper hole slightly to install the bolt. Install the 3/8 in. washer and nut and tighten to 30 ft. lbs.
- Check the underside of upper mount location on the vehicle for debris where the bracket will sit. This area must be free of any undercoating, dirt or other debris to ensure the bracket will sit flat against the sheet metal.

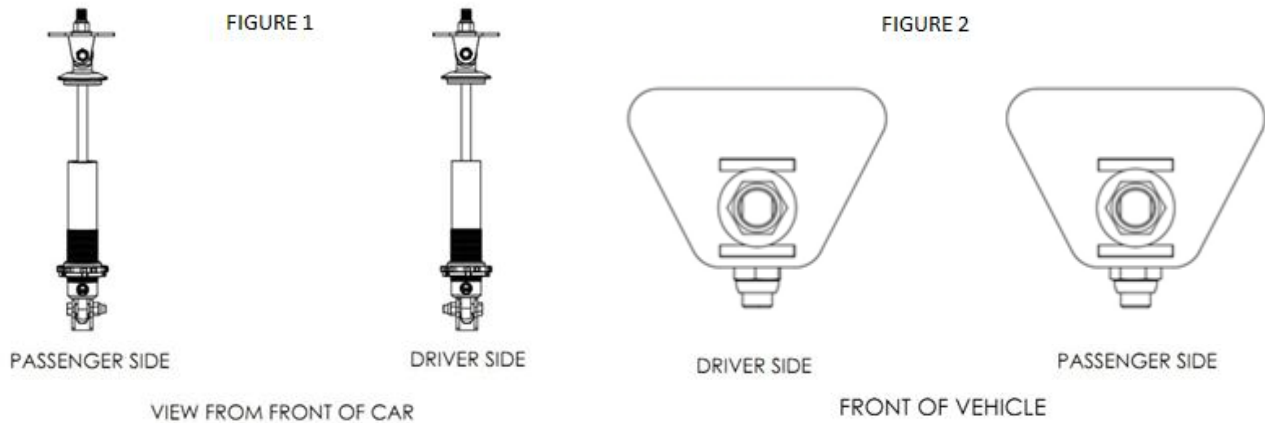

**Note:** Observe the installed orientation of the hardware (figure 1) in relation to the shock. The spring is not shown.

- Install the coil-overs into the vehicle guiding the upper bracket stud through the mount hole with the brackets turned in the correct orientation per figure 2. With the adjuster knobs facing forward install the lower bearing mount into the lower bracket and align holes, it may be necessary to spread the bracket slightly to fit the lower bearing into the mount. Install the ½ in. X 2-1/4 in. bolt and ½ in. Nylock nut into the lower mount hole and tighten to 50 ft. lbs.
- Lower the weight of the vehicle on its tires, it may be necessary to help guide the upper mount stud through the hole as the vehicle is lowered. DO NOT PLACE FINGERS BETWEEN THE BODY AND UPPER MOUNT, USE THE SHOCK SPRING AS A HANDLE TO GUIDE THE SHOCK. Install 5/8 in. washer and 5/8 in. Nylock nut to the top mount stud and tighten to 60 ft. lbs.
- Place the vehicle on the ground and check the vehicle ride height. Adjust the spring seat adjuster nut up or down the threaded shock body to gain your desired ride height. After ride height is set check to ensure you have proper shock

travel. A good rule of thumb is that 60% of the stroke should be available for compression. If the ride height is not correct, damage to the shock may result and will not be covered under warranty.

10. Check for a minimum clearance of 3/8 in. between lock nut, spring seat and the axle per Figure 2 with the vehicle weight supported by the tires. It may be necessary to trim a small amount off the factory axle bracket in order to obtain correct ride height and proper clearance between the spring seat and the axle. Check around shock and spring assembly and verify proper clearance for brake lines, cables and exhaust.

**To further upgrade your suspension, use other QA1 suspension products such as coil-overs, shocks, struts, springs, K-members, torque arms, panhard bars, sub-frame connectors, strut tower braces, rod ends, sway bars, tubular control arms, spherical bearings, and more.**