



INSTALLATION INSTRUCTIONS

QA1 1967-1979 Mopar A-Body Rear 6 link [Conversion System](#)

QA1 p/n R401-170, R401-200, R401-220, R201-170, R201-200, R201-220, R101-170, R101-200, R101-220

READ ALL INSTRUCTIONS CAREFULLY AND THOROUGHLY PRIOR TO STARTING INSTALLATION. PRODUCTS THAT HAVE BEEN INSTALLED ARE NOT ELIGIBLE FOR RETURN. USE THE PROPER JACKING LOCATIONS. DEATH OR SERIOUS INJURY CAN RESULT IF INSTRUCTIONS ARE NOT CORRECTLY FOLLOWED. A GOOD CHASSIS MANUAL, AVAILABLE AT YOUR LOCAL PARTS STORE, MAY ALSO AID IN YOUR INSTALLATION.

• DISCLAIMER / WARRANTY •

QA1 WARRANTS THAT THE PRODUCTS WILL BE FREE FROM DEFECTS IN MATERIAL AND WORKMANSHIP FOR ONE YEAR FROM DATE OF SALE TO THE ORIGINAL PURCHASER. QA1 MAKES NO OTHER WARRANTY OF ANY KIND, EXPRESSED OR IMPLIED. QA1 SHALL HAVE NO OBLIGATION UNDER THE FOREGOING WARRANTY WHERE THE DEFECT IS THE RESULT OF IMPROPER OR ABNORMAL USE, YOUR NEGLIGENCE, VEHICLE ACCIDENT, IMPROPER OR INCORRECT INSTALLATION OR MAINTENANCE, NOR WHEN THE PRODUCT HAS BEEN REPAIRED OR ALTERED IN ANY WAY. QA1'S LIABILITY IN THE CASE OF DEFECTIVE PRODUCTS SUBJECT TO THE FOREGOING WARRANTY SHALL BE LIMITED TO THE REPAIR OR REPLACEMENT, AT QA1'S OPTION, OF THE DEFECTIVE PRODUCTS.

THE USER UNDERSTANDS AND RECOGNIZES THAT RACING PARTS, SPECIALIZED STREET ROD EQUIPMENT, AND ALL PARTS AND SERVICES SOLD BY QA1 ARE EXPOSED TO MANY AND VARIED CONDITIONS DUE TO THE MANNER IN WHICH THEY ARE INSTALLED AND USED. QA1 SHALL BEAR NO LIABILITY FOR ANY LOSS, DAMAGE OR INJURY, EITHER TO A PERSON OR TO PROPERTY, RESULTING FROM THE INSTALLATION, DIRECT OR INDIRECT USE OF ANY QA1 PRODUCTS OR INABILITY BY THE BUYER TO DETERMINE PROPER USE OR APPLICATION OF QA1 PRODUCTS. WITH THE EXCEPTION OF THE LIMITED LIABILITY WARRANTY SET FORTH ABOVE, QA1 SHALL NOT BE LIABLE FOR ANY CLAIMS, DEMANDS, INJURIES, DAMAGES, ACTIONS, OR CAUSES OF ACTION WHATSOEVER TO BUYER ARISING OUT OF OR CONNECTED WITH THE USE OF ANY QA1 PRODUCTS. MOTORSPORTS ARE DANGEROUS; AS SUCH, NO WARRANTY OR REPRESENTATION IS MADE AS TO THE PRODUCT'S ABILITY TO PROTECT THE USER FROM INJURY OR DEATH. THE USER ASSUMES THAT RISK!

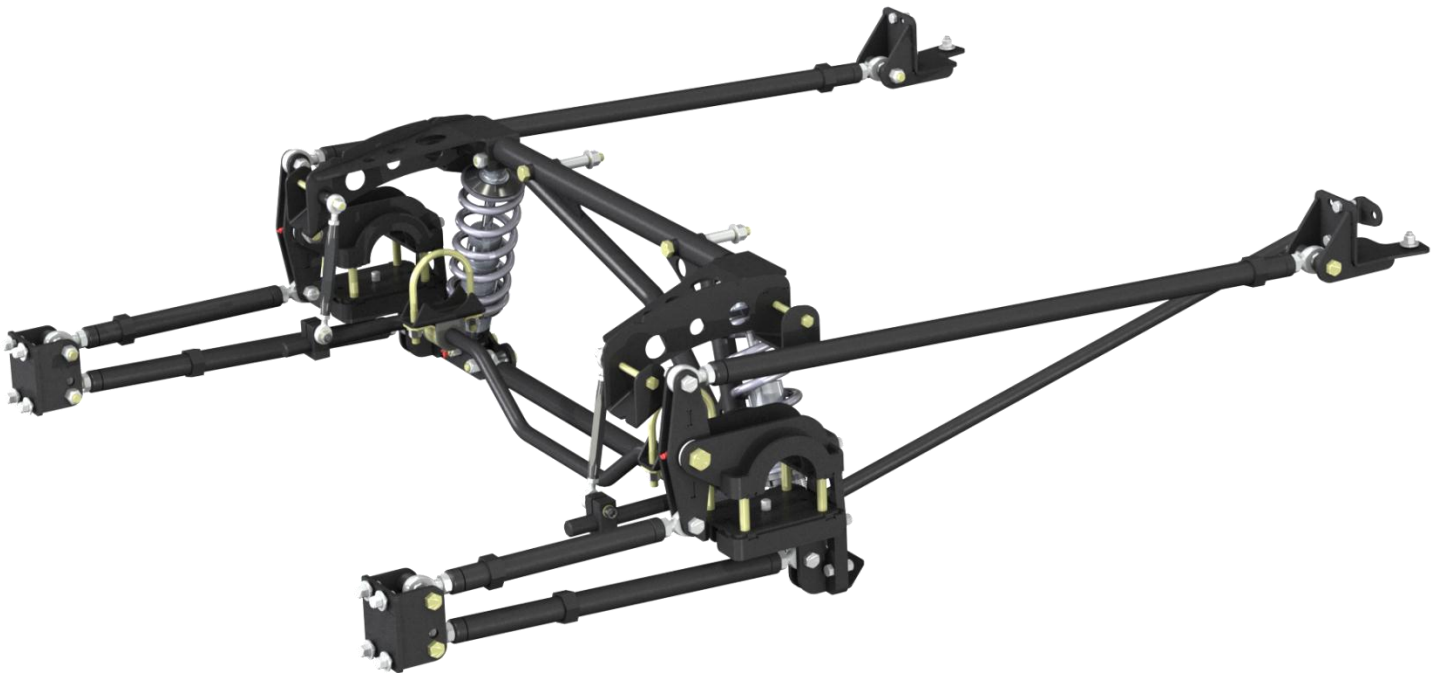

DO NOT VOID YOUR WARRANTY!

Permatex® Anti-Seize Lubricant should be used on coil-over threads to prevent galling. Failure to lubricate the coil-over threads with Anti-Seize prior to making ride height adjustments will cause damage to your shock absorber and will void any warranty. All ride height adjustments must be made with the vehicle weight completely unloaded from the suspension.

TOOLS AND SUPPLIES REQUIRED

- Floor Jack
- Jack Stands
- Tire Chocks
- Permatex® Anti-Seize Lubricant
- Tape Measure
- Drill & 3/8" bit
- Torque Wrench
- Common Hand Tools

SYSTEM CONTAINS

- Two (2) QA1 Coil-Over Shocks
- Two (2) Coil-Over Springs
- Mounting Brackets
- Suspension links
- All Necessary Hardware
- Spanner Wrench (QA1 P/N T114W)

Pre-installation Notes:

1. This system is designed to be used with the Chrysler 8 3/4" rear axle with 3 inch diameter axle tubes. The brackets may not fit correctly with other axle housings due to differences in axle tube diameter.
2. Spray all fasteners with penetrating oil before beginning disassembly of the rear suspension.
3. The factory steel fuel line will need to be repositioned for installation of this system. If the factory steel line is rusted, a replacement fuel line may be needed.
4. The flanges on the seam of the fuel tank may need to be bent upwards for clearance in a few locations. See step 13.
5. This system may require modification of the exhaust system as there is not clearance for exhaust around the rear suspension. Exhaust "dumps" or side exit exhaust in front of the rear wheels is recommended.

Coil-Over Shock Assembly:

1. Using a snap ring pliers, install a snap ring into one of the grooves in the shock eyes followed by the spherical bearing and the other snap ring. If pressing the bearing in, only press on the race of the bearing.
2. Screw the aluminum jam nut (shoulder up) and the spring seat adjuster nut (shoulder up) down to the last thread - NO FURTHER. Now is a good time to lubricate the threads of the shock body with **Permatex® Anti-Seize Lubricant**. See **Figure 1**.
3. QA1 highly recommends using the QA1 thrust bearing kit (part #7888-109) for ease of adjustment. If the thrust bearing kit is used, coat both washers with **Permatex® Anti-Seize Lubricant**. Install the stainless steel spring seat washer, then the bearing, followed by the second washer. If the thrust bearing kit is not used, coat one side of the stainless steel spring seat washer with **Permatex® Anti-Seize Lubricant**.
4. Place the lubricated side of the washer down on the spring seat. Slide the spring over the shock body and down onto the spring seat. Slip the spring cap in place, making sure that it is set in the spring squarely.
5. Adjust the spring seat up until the spring is slightly compressed. This ensures that the spring cap, spring and spring seat washer remain in place and aligned.



Figure 1

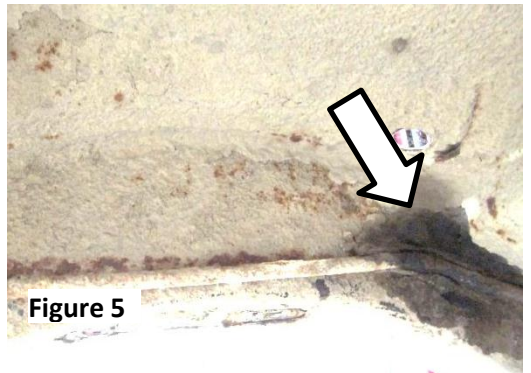
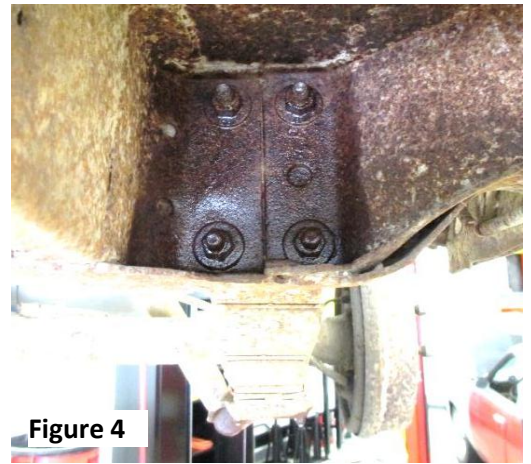
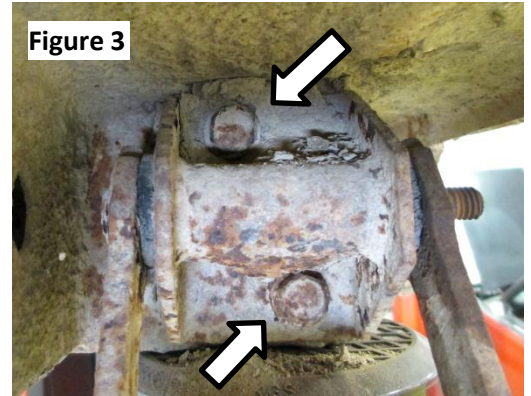

Figure 2

Disassembly:

1. With the car sitting at ride height on a level surface, measure the vehicle ride height at the center of the rear wheel well and record this measurement. (**Figure 2**) This will be useful when adjusting ride height after installation.
2. Measure and record the wheel base measurement on each side of the car and record these measurements.

3. Raise and support the vehicle securely on jack stands or on a hoist by the frame rails. A floor jack and jack stands will be needed to support the rear axle during disassembly and installation of the rear suspension. A hoist is highly recommended.
4. Remove the rear wheels. Note: Some Chrysler products use left hand threaded lug nuts on the left side of the vehicle and right hand threaded lug nuts on the right side of the vehicle.
5. Remove the driveshaft from the vehicle to prevent damage and provide easier access to the rear suspension.
6. With jack stands under the rear axle, remove the lower shock mounts and U-bolts. Placing a third jack stand under the pinion will prevent the axle from rotating forward when the U-bolts are removed. Note: If the 8 3/4" axle is going to be reused the U-bolts will need to be removed. If the axle is going to be replaced, the axle and leaf springs can be removed as one assembly. This will also require the brake hose and emergency brake cables to be disconnected.
7. Remove the two bolts for the rear spring hangers from the frame mount. See **Figure 3**.
8. Remove the four nuts from the front spring hangers on each side of the vehicle and remove the springs from the vehicle. See **Figure 4**.
9. Remove the upper shock mounting bolts. It may be necessary to hold the bolts under the car with locking pliers while the nuts are removed in the trunk.
10. Removal of the factory bump stops is recommended for easier installation of the panhard bar mount. The bump stops should be reinstalled after the system is installed.
11. Remove the bolt retaining the fuel line to the frame (**Figure 5**) and gently bend the fuel line out away from the frame rail so any undercoating and debris can be cleaned from the frame rail. It may be necessary to disconnect the fuel line from the fuel tank.
12. The front and rear leaf spring mounting locations need to be cleaned of undercoating, debris and rust before the supplied brackets can be installed for the 6 Link System. See **Figure 6 and 7**.



13. Clean the inside, outside and bottom of the frame rails of undercoating and repair any rusted areas before continuing. The upper shock mounting locations also need to be cleaned of undercoating. See the arrows in **Figure 8**. The panhard bar support can be held in place to show the specific locations.

14. The flange on the front of the fuel tank must be folded up to prevent interference between the fuel tank and the coil-over springs and the diagonal tube of the panhard bar support. See the circled areas in **Figure 8**.

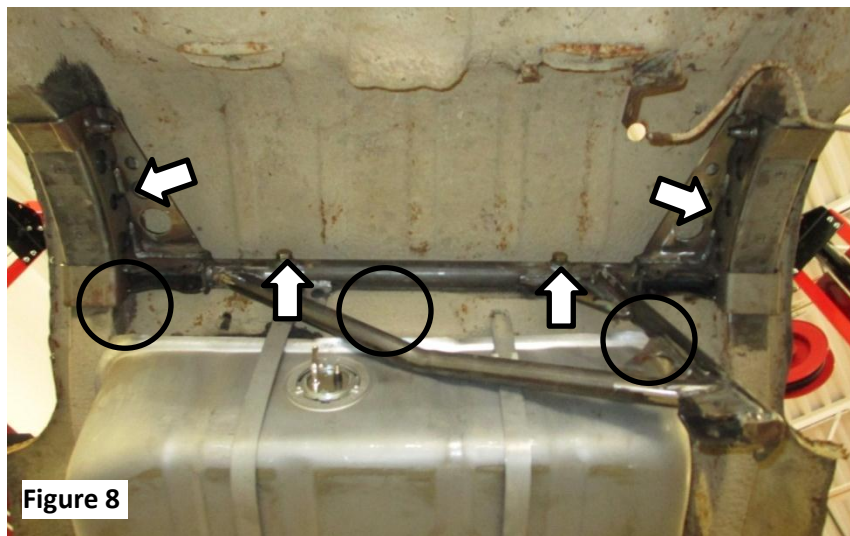

Figure 8

Installation:

1. Install the rear chassis mounts (p/n 9637-259 and p/n 9637-256) on the cleaned rear leaf spring mount using two (2) 3/8" x 1" bolts (p/n 9012-229) in the threaded holes. The brackets are right and left specific and should follow the contour of the mount. A third 3/8" x 1" bolt (p/n 9012-229) should be installed with a 3/8" washer (P/N 9005-111) under the head of the bolt and 3/8" nut (p/n 9014-253). See **Figure 9**.



Figure 9



Figure 10



Figure 11

2. Install the front chassis mounting brackets (p/n 9637-249) in the front leaf spring mounting location. The brackets should have the two holes closest to each other towards the ground. See **Figure 10**. Use four (4) 3/8" x 1 1/4" bolts (p/n 9012-229), washers (p/n 9005-111) and 3/8" nuts (p/n 9014-253).

3. The rear coil-over cross member (p/n 9637-233) can now be installed on the frame rails. Begin by installing sleeve p/n 9033-420 into the factory shock bolt mounting holes in the cross member from under the car. The taper on the outside of the sleeves should be towards the front of the car. **Figure 11**

4. With the sleeves inserted, position the on the frame rails and install the two (2) 1/2" x 4 3/4" bolts (p/n 9012-260) from under the car. Install the washers (p/n 9005-228) and nuts (p/n 9014-279) from inside the trunk.

5. Once the coil-over cross member is in place and tight to the frame rails, the four (4) 3/8" holes can be drilled in the frame rails using the bracket as a drill guide. Drilling the holes from each side of the rail is recommended to ensure correct alignment. The inner rear holes will need to be marked and the brace removed in order to drill the holes. Placing masking tape on the frame rails will help protect the paint.

6. With all of the holes drilled, reinstall the coil-over cross member and insert the two (2) 3/8" x 3 3/4" bolts (p/n 9012-258) in the rear holes and the two (2) 3/8" x 5 1/2" bolts (p/n 9012-257) in the front holes. **Figure 12**



7. Assemble the sway bar end links using p/n JNR6S and p/n JNL6S jam nuts on p/n XMR6 and p/n XML6 rod ends. Thread the rod ends into the adjusting sleeves (p/n 9033-417).

8. Install the sway bar end link assemblies on the 3/8" x 5 1/2" bolts in the front mounting holes of the coil-over cross member with 3/8" washer (p/n 9005-245) and 3/8" nut (p/n 9014-253) and tighten. The nuts can also be installed and tightened on the rear bolts for the coil-over cross member. See **Figure 13**.



9. Install the rear mount (p/n 9637-252) for the panhard bar support using the left side inner rear bumper support mounting bolt as shown in **Figure 14**. Assemble the panhard bar support link (p/n 9033-416) with p/n CR5-6 clevis and p/n JNR6S jam nut and p/n CL5-6 clevis and p/n JNL6S jam nut. Install the panhard bar support link with two (2) 5/16" x 1" bolts (p/n 9014-422) and lock nuts (p/n 9014-424). **Note:** The flange on the fuel tank weld seem may need to be bent up for clearance of the support.

10. Select the alignment nut (p/n 9014-475 or 9014-474) that fits in the leaf spring center pin hole on the axle spring perch and bolt the nut to the lower axle clamp (p/n 9637-219) using the 5/16" x 3/4" button head bolt (p/n 9012-245). **Figure 15**.

11. Install the shock mounting brackets (p/n 9637-225, 9637-227 left and p/n 9637-226, 9637-230 right) on the lower axle clamp with four (4) 3/8" x 1 1/4" bolts (p/n 9012-179) and nuts (p/n 9014-253). Bolting the shock mounts to the axle clamps before tightening the axle clamp bolts will help align the clamps on the spring perch and axle tube. The shock mounting brackets are right and left hand specific. The brackets shown in **Figure 16** are the left side.



12. Loosely mount the upper axle clamp (p/n 9637-213) and lower axle clamps on the axle tube using the remaining two (2) 3/8" x 1 1/4" bolts (p/n 9012-179) and nuts (p/n 9014-253). Install four (4) 1/2" x 3 1/2" bolts (p/n 9012-202) and nuts (p/n 9014-279). The tabs on the upper brackets will face towards the front of the vehicle. See **Figure 17**.

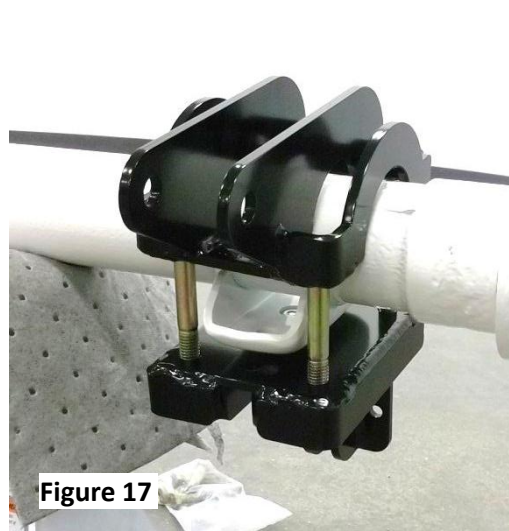

13. Tighten the four (4) bolts on each axle mount to the torque specifications listed on page 8.
14. Install the pivot assembly (p/n 9637-262) onto the upper axle clamp using 5/8" x 3 1/4" bolt (p/n 9012-259) and nut (p/n 9014-131). The pivot assembly is symmetric and can be mounted either way as long as the grease fittings face towards the front of the vehicle. See **Figure 18**.
15. Grease the inside of the sway bar bushings (p/n 9032-173) and install the sway bar bushings, brackets and sway bar clamps (p/n 9037-151) onto the sway bar (p/n 7039-181). The bar clamps may need to be spread open slightly with a screw driver to slide onto the bar. See **Figure 19**.
16. Measure 5 1/2" in on the axle tube from the axle clamp and place a mark on each side of the axle. This will be the center of the sway bar mounts. Install the sway bar mount saddles (p/n 9037-369) and sway bar on the axle tube using the supplied U-bolts (p/n 9012-204), 7/16" washers (p/n 9005-249) and 7/16" nuts (p/n 9014-442). Double check that the sway bar is centered before tightening. See **Figure 20**.



17. Assemble the front and rear links using the following rod end and jam nut part numbers: one XMR8-10, one XML10, one JNR10S and one JNL10S for each link. The panhard bar will use the following rod end and jam nut part numbers: one XMR10, one XML10, one JNR10S and one JNL10S. Thread the jam nuts all the way onto the rod ends and thread the rod ends fully into the links. This will help insure the link has equal threads on each end of the link.

18. Bolt the longest links (35.3", p/n 9033-412) to the top bolt hole on the pivot assembly with the links extending to the rear of the vehicle using the ½" x 1 ¾" bolts (p/n 9012-218) and ½" nuts (p/n 9014-279).

19. Bolt the shortest links (11.9" p/n 9033-413) to the bottom bolt hole on the pivot assembly with the links extending to the front of the vehicle using the ½" x 1 ¾" bolts (p/n 9012-218) and ½" nuts (p/n 9014-279).

20. Bolt the remaining two links (18.5" p/n 9033-414) to the lower axle clamp bracket with the links extending to the front of the vehicle using the ½" x 1 ¾" bolts (p/n 9012-218) and ½" nuts (p/n 9014-279).

21. Install the high misalignment spacers (p/n 9004-167) into the front rod ends (**Figure 21**) in the front links and bolt the front links to the front mounting brackets using the ½" x 3 ¾" bolts (p/n 9012-242) and nuts (p/n 9014-279).

22. Install the high misalignment spacers (p/n 9004-167) into the rear rod ends in the rear links and bolt the links the rear brackets using ½" x 3 ¾" bolt (p/n 9012-242) and nut (p/n 9014-279).

23. Install the shocks with the knobs facing towards the center of the vehicle. Use one (1) ½" x 2" bolt (p/n 9012-263) on top and one (1) spacer (p/n 9004-171) with ½" x 2 ¾" (p/n 9012-261) bolt on the bottom with nuts (p/n 9014-279). The spacers will be towards the rear of the vehicle. See **Figure 22**.

24. Install the panhard bar with a wide spacer (p/n 9004-168) on the right side (shock mount side) with the spacers towards the rear of the vehicle. Insert the ½" x 2 ¾" bolt (p/n 9012-261) with nut (p/n 9014-279). See **Figure 23**

25. Install the left side of the panhard bar with spacer p/n 9004-170 towards the rear of the vehicle with a ½" x 2 ¾" bolt (p/n 9012-262) and nut (p/n 9014-279).

26. Connect the sway bar end links to the sway bar clamps using the 3/8" x 2 ½" socket head bolts (p/n 9012-196). Washer p/n 9005-245 will be used on each side of the sway bar clamp and one between the bolt head and rod end. Use 3/8" nut p/n 9014-101. See **Figure 24**.

27. Reinstall the factory bump stops with the original hardware.

28. The fuel lines and driveshaft can now be reinstalled.

29. Reinstall the rear wheels.

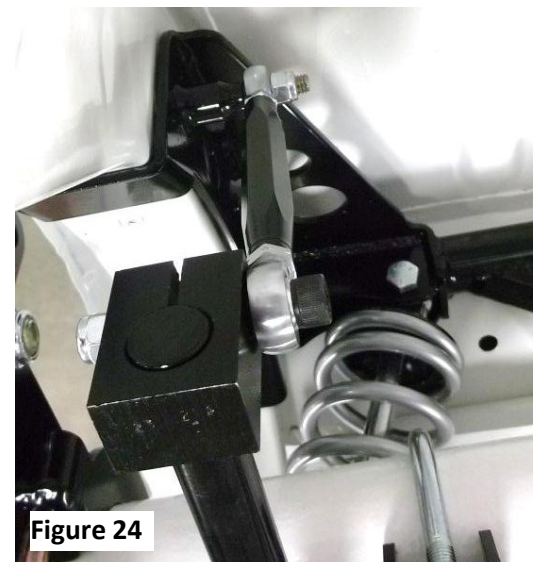
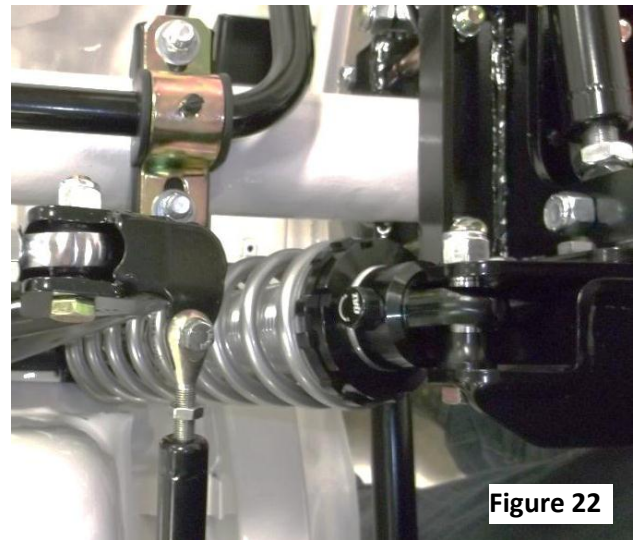

Adjusting the 6 Link System

1. Set the rear ride height by adjusting the spring seat adjusters on the coil over shocks with the QA1 spanner wrenches (p/n T114W) until the eyelet to eyelet length is between 13 ½" and 14 ½". Measuring from the center of the wheel opening to the ground on each side of the car will help with final ride height adjustments. (see **Figure 2**)
2. Set the wheel base by adjusting the lower links on each side of the car. Refer to the wheel base measurements that were taken in step two of the disassembly instructions.
3. Center the axle under the car by adjusting the panhard bar until the measurement from the frame rail to the tire is the same on both sides of the car.
4. Adjust the pinion angle by lengthening the upper links and the rear links until the pinion angle is set. Recommended pinion angle is -2° to -3°.
5. Once all adjustments are made to the rear suspension ensure all of the bolts and jam nuts are tightend to spec.

NOTE: A four wheel alignment recommended after any changes to the vehicles suspension.

Torque Specifications	
1/4" bolts	10 lb. ft.
5/16" bolts	19 lb. ft.
3/8" bolts	33 lb. ft.
1/2" bolts	78 lb. ft.
5/8" bolts	154 lb. ft.

ITEM NUMBER	PART NUMBER	DESCRIPTION	QTY.
1	9637-213	Weldment, Upper Axle Clamp Asm.	2
2	9637-219	Weldment, Lower Axle Clamp Asm.	2
3	9637-225	Plate, LH Shock Mount Base	1
4	9637-226	Plate, RH Shock Mount Base	1
5	9637-227	Weldment, LH Shock Mount	1
6	9637-230	Weldment, RH Shock Mount	1
7	7039-181	Sway Bar, Rear, Mopar A-Body	1
8	9037-369	Axle Saddle Bracket	2
9	9037-151	Sway Bar Block 7/8"	2
10	9012-204	U-Bolt, 7/16-20 X 3.0"	2
11	9032-173	Bushing Kit, Sway Bar Frame Mount	1
12	9033-414	Link Rod, Lower	2
13	9033-415	Link Rod, Panhard Bar	1
14	9033-412	Link Rod, Rear	2
15	9033-413	Link Rod, Upper	2
16	9637-262	Rocker Assembly	2
17	XMR8-10	Rod End, 1/2-5/8 RH	6
18	XML10	Rod End, 5/8 LH	7
19	XMR10	Rod End, 5/8 RH	1
20	9637-256	Weldment, Rear Chassis Mount	1
21	9637-259	Weldment, Rear Chassis Mount	1
22	9637-233	Weldment, Rear Coilover Crossmember	1
23	9637-249	Weldment, Front Chassis Mount	2
24	9033-417	Sleeve, Link 5/8" X 5.13"	2
25	XMR6	Rod End, 3/8 RH	2
26	XML6	Rod End, 3/8 LH	2
27	9005-245	Washer, Flat 3/8" AN960-616	8
28	CR5-6	Clevis, .3125 X 3/8-24, RH	1
29	CL5-6	Clevis, .3125 X 3/8-24, LH	1
30	9033-416	Link, Panhard Support	1
31	9637-252	Bracket, Support Rod Mount	1
32	JNR10S	Nut, Jam 5/8-18 RH	7
33	JNL10S	Nut, Jam 5/8-18 LH	7
34	JNL6S	Nut, Jam 3/8-24 LH	3
35	JNR6S	Nut, Jam 3/8-24 RH	3

ITEM NUMBER	PART NUMBER	DESCRIPTION	QTY.
36	9004-167	Spacer, Stepped, .84 Width	12
37	9004-168	Spacer, Stepped, .75 Width	1
38	9004-170	Spacer, Stepped, .25 Width	1
39	9004-171	Spacer, Stepped, .5 Width	2
40	9012-257	Bolt, Hex 3/8-16 x 5.5 Gr. 8	2
41	9012-258	Bolt, 3/8-16 x 3.75 Gr. 8	2
42	9014-253	Nut, Nylock 3/8-16	24
43	9014-101	Nut, 3/8-16 Nylock Jam	4
44	9012-196	Bolt, SHCS, 3/8-16 x 2.5	2
45	9012-245	Bolt, Button Head 5/16-18 X .75"	2
46	9014-475	Nut, 5/16-18, 1/2" Round Head	2
47	9012-259	Bolt, 5/8-11 x 3.25, Grade 8	2
48	9014-131	Nut, Nylock 5/8-11	2
49	9033-420	Sleeve, Upper Crossmember Bolt	2
50	9005-228	Washer, Flat 1/2"	2
51	9012-260	Bolt, 1/2-13 x 4.75, Grade 8	2
52	9014-279	Nut, Nylock 1/2-13	28
53	9012-242	Bolt, 1/2-13 x 3.75 Grade 8	6
54	9012-261	Bolt, 1/2-13 x 2.75, Grade 8	3
55	9012-262	Bolt, 1/2-13 x 2.25, Grade 8	1
56	9012-218	Bolt, 1/2-13 X 1.75" Gr. 5	6
57	9012-202	Bolt, 1/2-13 x 3.5 Grade 8	8
58	9012-263	Bolt, 1/2-13 x 2.0, Grade 8	2
59	9014-442	Nut, Nylock, 7/16-20	4
60	9005-249	Washer, Flat 7/16" Thick	4
61	9012-179	Bolt, 3/8-16 x 1.25	12
62	9012-229	Bolt, 3/8-16 x 1 Gr. 5 ZC	14
63	9005-111	Washer, Flat, 3/8" USS	10
64	9014-474	Nut, 5/16-18, 5/8" Round Head	2
65	9014-422	Bolt, 5/16-18 x 1.0 Gr. 5	2
66	9014-424	Nut, Nylock 5/16-18	2
	9093-120	DECAL, CONTINGENCY-8"	2
	T114W	WRENCH KIT, D&S COIL-OVER SPANNERS	1
		QA1 ADJUSTABLE COIL-OVER SHOCKS	2
		SPRING, CR-SI HIGH TRAVEL 2 1/2" ID	2

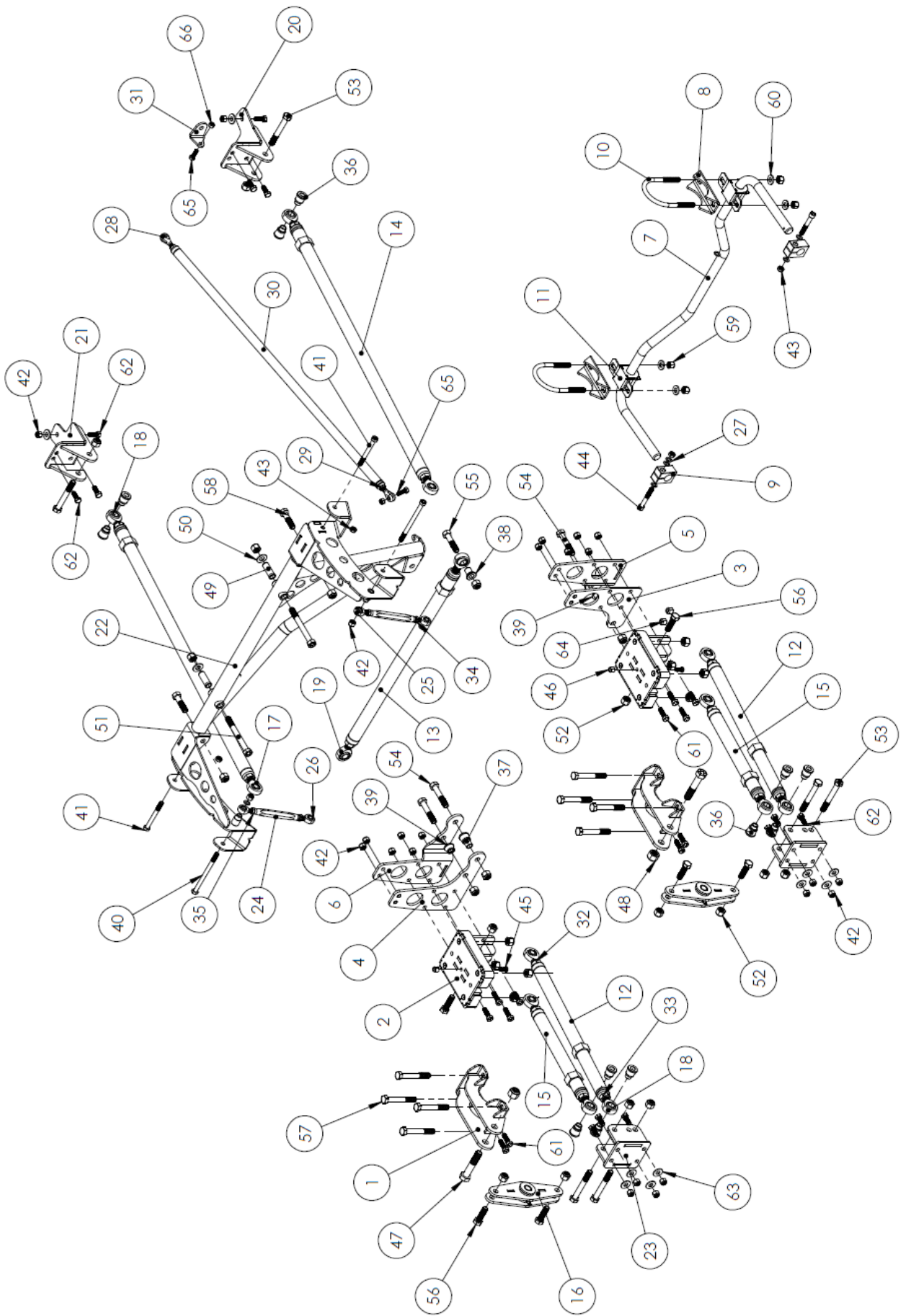

To further upgrade your suspension, use other QA1 suspension products such as coil-overs, shocks, struts, springs, K-members, torque arms, panhard rods, sub-frame connectors, strut tower braces, rod ends, sway bars, tubular control arms, spherical bearings, carbon fiber driveshafts and more.