

PUTCO®

MOLLE PANELS

- MODULAR LIGHTWEIGHT LOAD CARRYING EQUIPMENT -

INSTRUCTION GUIDE

CHEVROLET

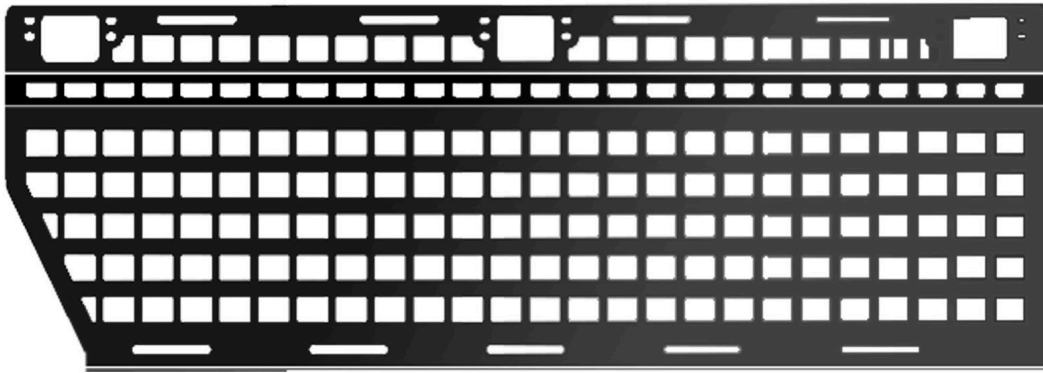

FRONT PANEL



**PLEASE READ ALL INSTRUCTIONS BEFORE INSTALLATION
AND CHECK TO SEE THAT ALL PARTS ARE INCLUDED**

REQUIRED TOOLS

3/16" HEX KEY



T30 TORX DRIVE



10MM WRENCH



FLATHEAD SCREWDRIVER



CONTENT LIST

DESCRIPTION	QTY
Molle Front Plate	1
Brackets	3
M6 Bolts	12
Tabbed Washer	3
5/16-18 X 2' Button Head Bolt	3
Threaded Nut Plate	3
Rubber feet	4
Jam nuts	4



INSTALLATION INSTRUCTIONS

- 1** Begin by locating and removing the necessary plastic oval covers from the slots in the bed using a small flat-head screwdriver.
- 2** Next, loosely assemble a 5/16 bolt, tabbed washer, and nut plate to each bracket as shown.

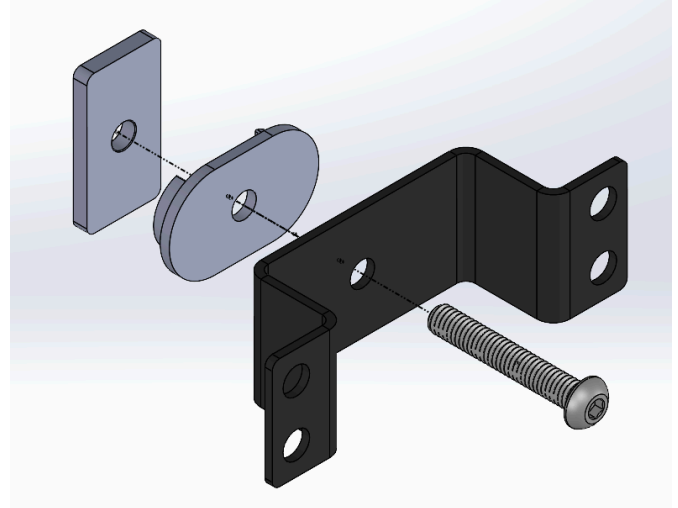

- 3** Grab one of the assembled brackets and insert the nut plate into one of the required bed slots. The nut plate will have to be inserted at an angle in order to fit. During this process, use caution so you do not loosen the nut plate and drop it behind the slot! Next, orient the nut plate so that it is perpendicular and centered behind the slot, then push the tabbed washer against the bed side so that the tabs fit into the slot. If aligned correctly, the tabs should prevent the nut plate from spinning. While keeping the tabbed washer in the slot pull back on the bolt and begin to tighten. Do not fully tighten, as the position of the bracket may need to be adjusted. Repeat this process for the rest of the required slots in the bed.

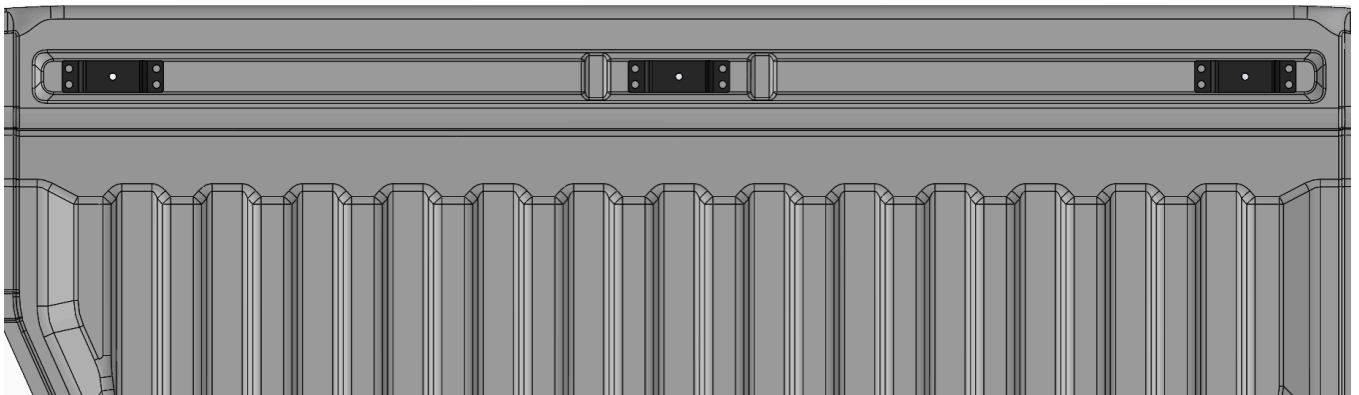

- 4** Next, loosely assemble to front plate. Begin by loosely screwing a jam nut onto each of the rubber feet, then loosely screw the rubber feet into the riv-nuts in the bottom bend of the front plate.
- 5** Fasten the front plate onto the brackets using M6 bolts. The brackets may have to be adjusted to make the holes line up.



- 6** Once the front plate is secured to the brackets, adjust the rubber feet so that they sit tight to the bed of the truck. This helps prevent vibration while driving. Once the feet are in the correct position, tighten the jam nuts to secure them in place. The fully installed front plate should look like the figure below.

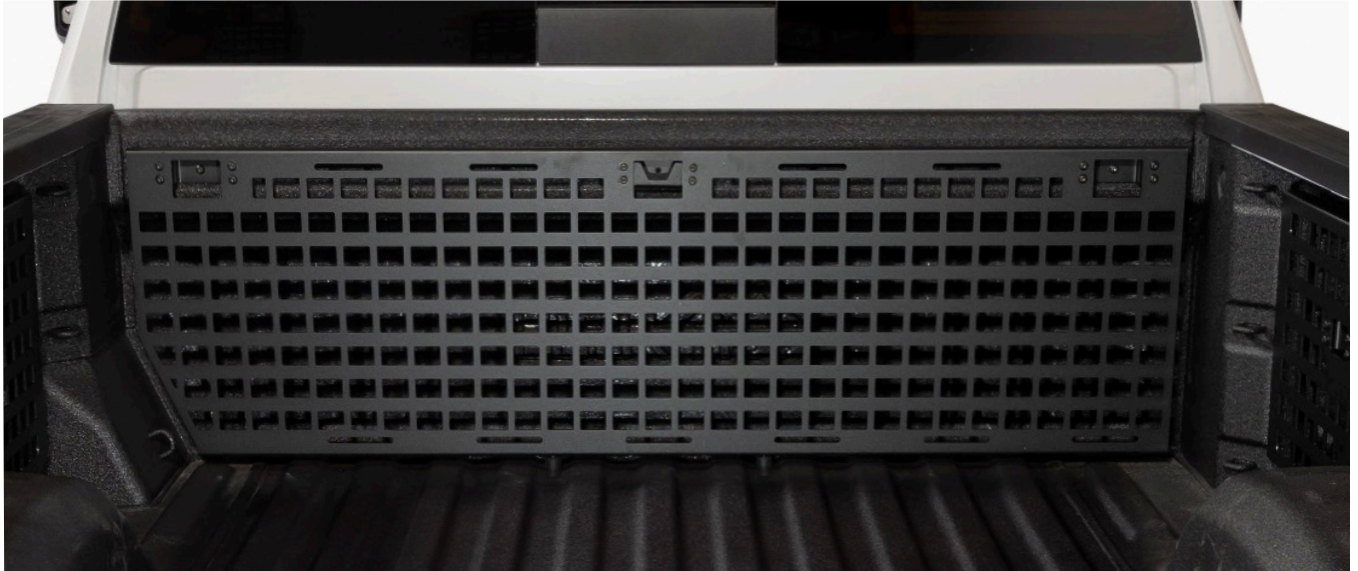

- 7** After the front plate is in place, go back and make sure that all fasteners are tight, including the ones in the center of the bracket. All the bolts should be snug, but do not overtighten!

Your new MOLLE Panel is now successfully installed on your vehicle!