

## **BOSS Grille Installation Instructions:**

*Please read all instructions before beginning installation and be sure to check to see that all parts and hardware are included.*

<b>Parts List</b>		
<b>Description</b>	<b>Parts</b>	<b>Quantity</b>
BOSS Grille	Supplied in Kit	1
¼" x 20 Bolt	Supplied in Kit	6
¼" x 20 Nylock Nut	Supplied in Kit	6
¼" Washer	Supplied in Kit	12
Spring Clips	Supplied in Kit	4
Screw with Washer	Supplied in Kit	4
SS Shroud Cover	Supplied in Kit	2

<b>Tools Required</b>			
10mm, 9/32", 7/16" Socket and Ratchet	Pliers	Needle Nose Pliers	Small Flat Blade Screwdriver
Drill	5/16" Drill Bit	Dremel or Side Cutter	Marker

**NOTE: IT IS RECOMMENDED THE INSTALLER/TECHNICIAN READ THE INSTRUCTIONS THOROUGHLY PRIOR TO INSTALLATION OF THIS PRODUCT.**

1. Open hood.
2. Remove eight push pins from the hood shroud and set aside for re-installation.
3. Remove four 10mm bolts from the top of the grille and set aside for re-installation.
4. Remove two fender screws (see figure 2b) from driver and passenger side wheel well and set aside for re-installation.

- Carefully unclip six retainer clips that are behind the grille near the radiator.
- Pull out on the plastic bumper cover sides near the front fenders and headlights to disengage the retaining tabs from the bumper (see figure 2a).



**CAUTION:** Take the proper precautions to protect the face of the bumper cover and grille from cosmetic damage.

- With help of an assistant, reposition the bumper cover and grille away from the vehicle. Place the bumper cover and grille on a clean workbench.
- Carefully push out the six retaining tabs located at the bottom of the grille by pressing the tabs down and pushing them out of the grille.

**CAUTION:** Take the proper precautions to protect the face of the bumper cover and grille from cosmetic damage.

- Remove the grille from the plastic bumper cover (see figure 2c).

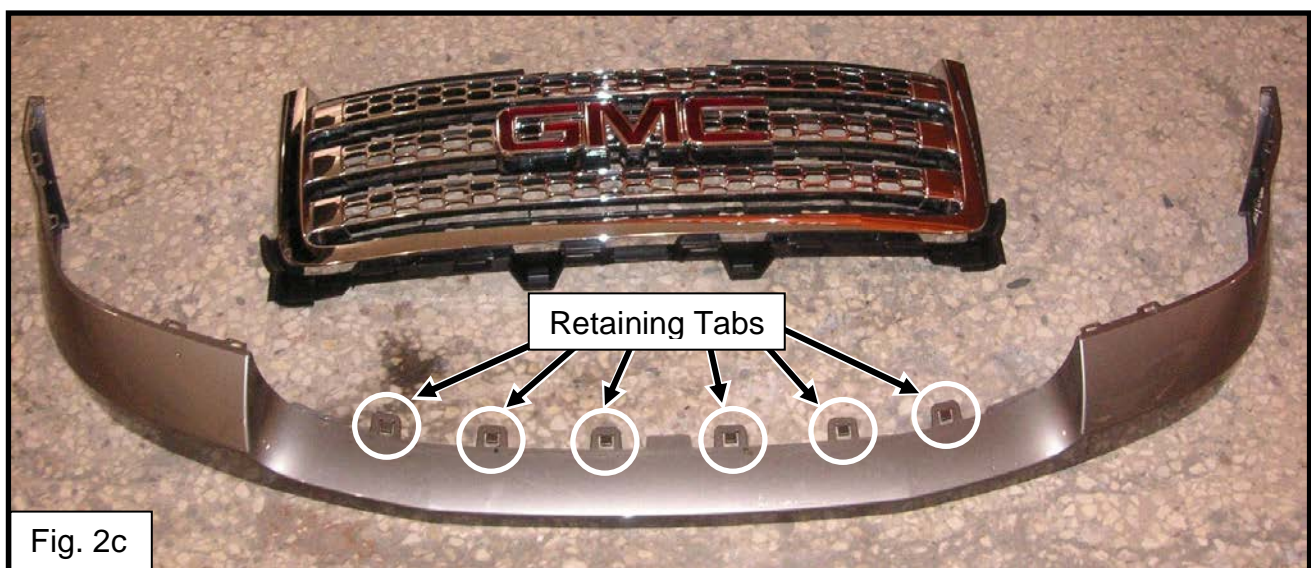

10. Set the grille on a sturdy non-abrasive surface.
11. Review figure 3a and 3b before cutting your factory grille. You will need to remove the center section of the factory grille that is shaded gray in figure 3a.

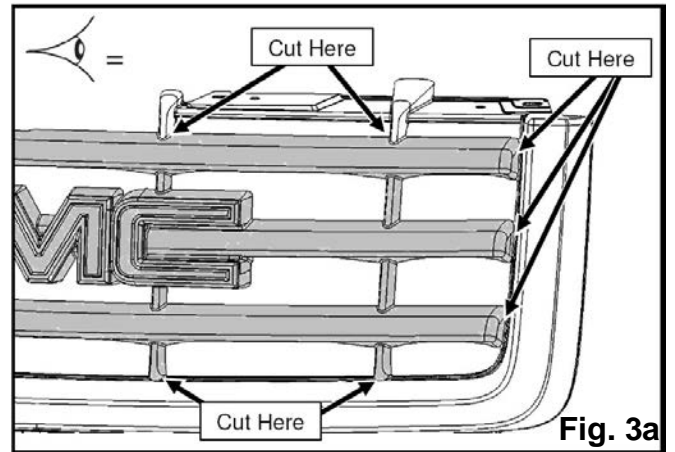

12. Carefully cut out the center section of the factory grille. Use the dashed lines in figure 3b as a guide for cutting. When you have removed the center grille section it should look like figure 3c. Make sure all cuts are flush. **(Note: Discard the center section of the factory grille.)**

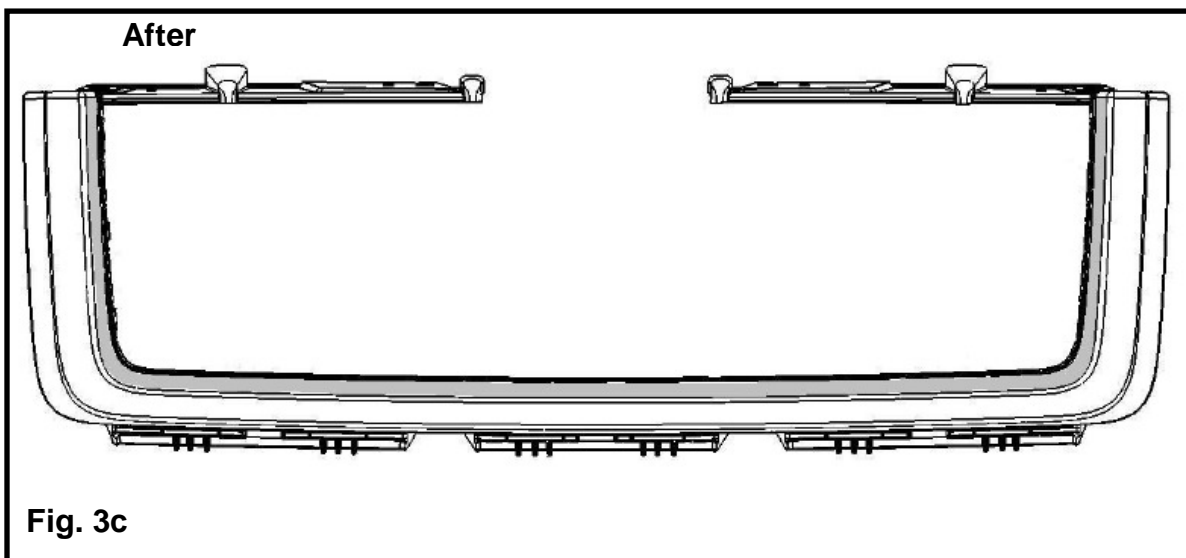
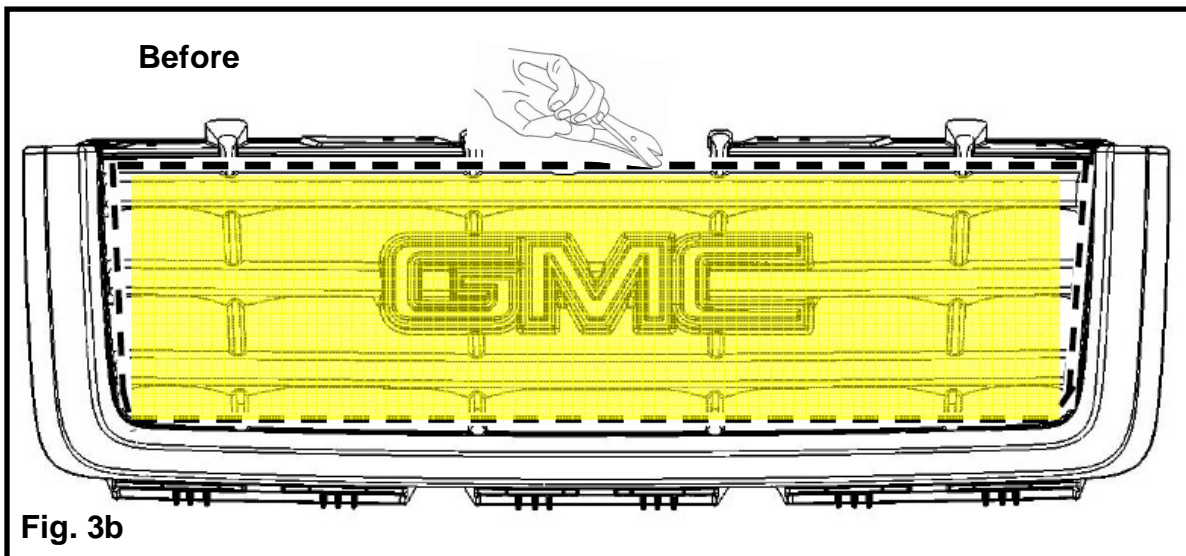



13. Position and align the **BOSS Grille** inside the factory surround. Mark the mounting locations using the brackets on the back side of the grille with a marker.  
**(Note: Ensure that the grille is centered and aligned before drilling.)**
14. Remove **BOSS Grille** from the factory surround and drill six holes using a 5/16" drill bit. Use the marks made in step 13 as a guide for drilling.
15. Insert the **BOSS Grille** into the factory surround. Align the mounting tabs with the drilled holes.
16. Secure the grille to the factory surround using the hardware provided.

17. Temporarily attach grille/surround to the vehicle using the four 10mm bolts and retainer clips. Verify that the grille is centered and aligned (see figure 4a).



18. Remove grille/surround from the vehicle and make adjustments if needed.
19. Attach *spring clips* to the top four mounting brackets and attach the two *SS Shroud Covers* using the *screws* provided.
20. Tighten all hardware so the grille is secured to the factory surround.
21. Re-assemble the bumper cover to the grille by aligning the six plastic tabs and connecting the two together. **(See Figure 2c)**
22. Attach the grille and bumper cover to the front end by aligning the three plastic guides that attach to the bumper and pressing inwards near the headlights and fenders.
23. Verify that the bumper cover and retainer clips are fully engaged and that the grille is secure.
24. Re-attach the four 10mm bolts that were removed in Step-3 and tighten down.
25. Re-attach the fender screws to both driver and passenger side.
26. Re-attach the hood shroud cover that was removed in Step-2.
27. Close hood and confirm that all components and hardware are tightened up and secure.