

2014+ Chevy Silverado/GMC Sierra LD Push Up Tie Down Rear Installation Instructions

KIT CONTENTS:	
Description	Qty.
Push Up Tie Down	1
1/4"-20 X 3 1/2" SS Hex Head Bolt	4
Rubber Gasket	2
1/4"-20 SS Threaded Plate	4
Mounting Bracket	2
Stake Pocket Adapter Plate Drivers Side	1
Stake Pocket Adapter Plate Pass Side	1
3/8"-16 SS Hex Bolt	2
3/8" Flat Washer	2

Tools Needed:

- 5/32 Hex Key
- 9/16" Wrench
- Dremel

Push Up Tie Down Installation

1. Remove Push Up Tie Down kit from packaging. Verify all parts from above kit contents table are included.
2. The front stake pocket holes are covered with a plastic bed cap. Using a "Dremel" or similar tool, cut out the plastic covering the hole, as indicated by the molded outline in the plastic bed cap.
3. Loosely assemble all the components from the kit as seen in **Figure 2**. The entire assembly will drop in as one unit.

Note: Ensure that the adapter plate corresponds to the direction of the mounting Bracket.
Refer to **Figure 1**.

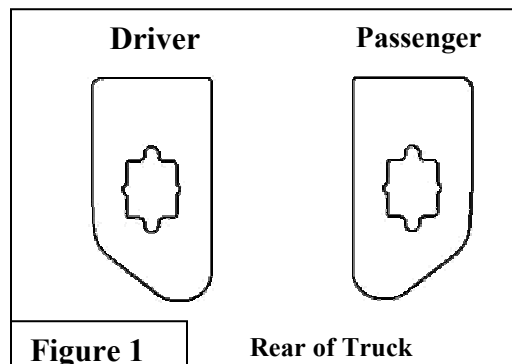

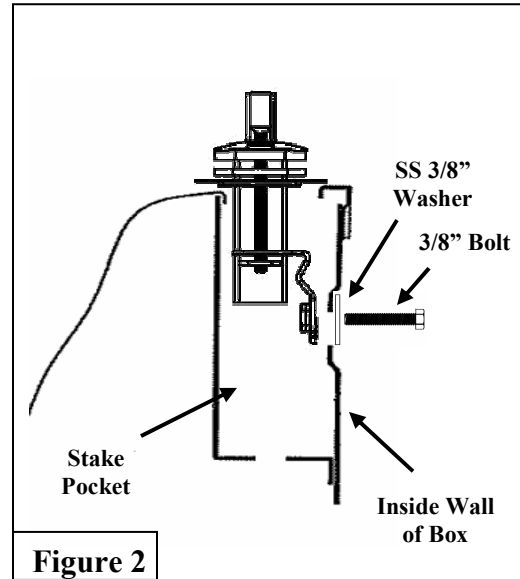
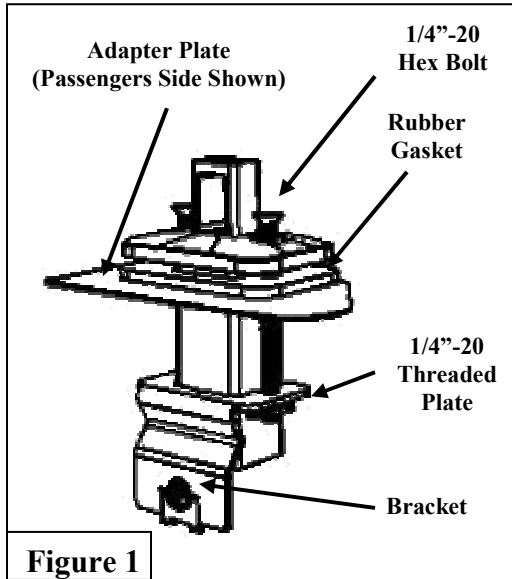

4. Drop the assembly into the rear stake pocket as shown in **Figure 2**. Move the assembly around until the Bracket lines up with the hole in the Inside wall of the box. Thread the Bolt with washer by hand until snug to avoid cross threading.
5. With a 5/32 Hex key evenly tighten the two Hex Bolts on the tie down making sure the adapter plate and tie down is centered in the pocket.
6. Fully tighten all bolts. Check that the tie down is functioning properly.