

2014+ Chevy Silverado/GMC Sierra LD & 2015+ Canyon/Colorado Locker Rail Installation **Instructions**

KIT CONTENTS:	
Description	Qty.
Locker Castings	4
SS Tubes	2
Rubber Expander	2
Cover Plate-Driver Side	1
Cover Plate-Passenger Side	1
Rear Stake Pocket Bracket	2
5/16" x 2 1/2 " Bolt	2
5/16" x 3" Fully Threaded Bolt	2
Plastic Washer (Not Contained in all kits)	4
3/8" Flat Washer	2
3/8"-16 SS Hex Bolt	2
Threaded Plate	4
Black Plastic Gasket	4
Black Plastic Bushing (Not contained in all kits)	4

Tools Needed:

- 9/16" Wrench
- 1/4" Hex Wrench
- Dremel
- Drill (If Drilling)
- 7/16" Drill Bit (If Installing with Tonneau Cover)
- 5/16" Drill Bit (If Installing with Toolbox)
- Torque Wrench (If installing Nylon Castings)

Locker Rail Installation

1. Remove locker kit from packaging. Verify all parts from above kit contents table are included.
2. The front stake pocket holes are covered with a plastic bed cap. Using a "Dremel" or similar tool, cut out the plastic covering the hole, as indicated by the molded outline in the plastic bed cap.
3. Assemble castings and mounting hardware for the front two stake pockets. Put plastic washer on the bolt and insert the bolt through the top of the casting. Insert the gasket, expander, and threaded plate on the bottom and finger tighten and place in front stake pockets as shown in **Figure 1**.
4. Place a bushing on each casting so that the tabs face towards the tube.

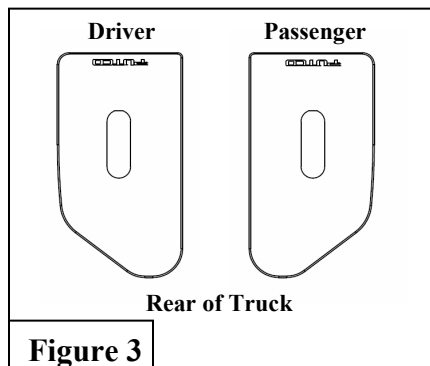
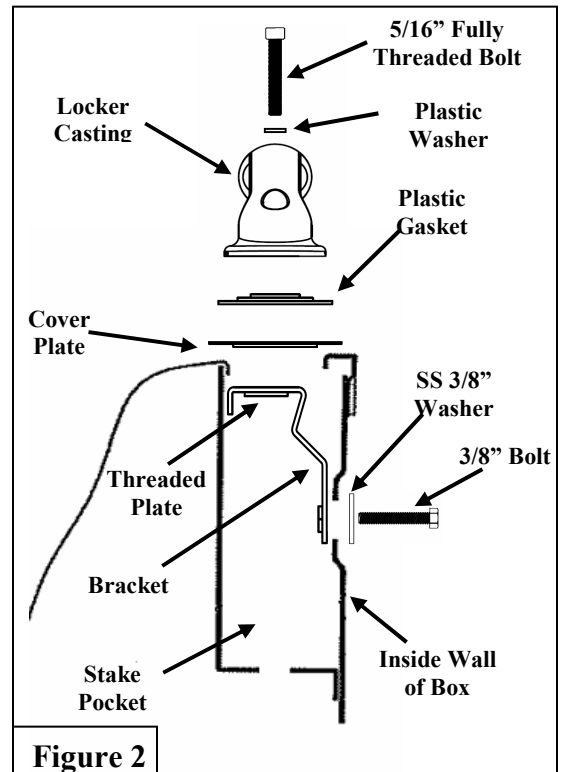
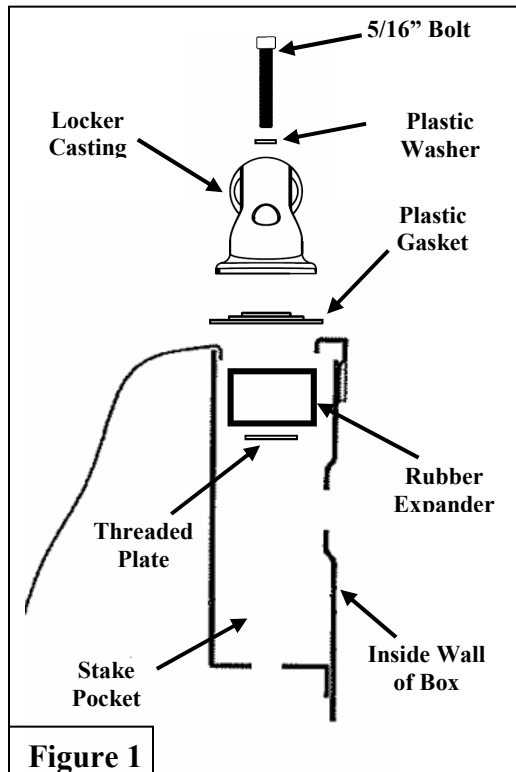

5. Assemble castings and mounting hardware for the rear two stake pockets. Install plastic washer on the bolt and insert the bolt through the top of the casting. Slide gasket, cover plate, bracket w/clip nut and threaded plate on the bottom of the casting and leave loose as shown in **Figure 2**
6. Install bushing on locker castings and insert the casting into the tubes (**If tube is tight on casting use a rubber mallet to install, be careful not to scratch the casting**)
7. Install assembled rail on truck by sliding tube into front locker casting and inserting the rear casting assembly (Put together in step 5) into rear stake pocket and position it as shown in **Figure 2**. Verify that the correct cover plate is installed for the correct side of the truck.(**Figure 3**)

8. Install the 3/8" bolts with washers into the clip nuts on the rear brackets through the inside surface of the truck box. Tighten with 9/16" wrench as shown in **Figure 2**. (If installing with tonneau cover, use **Figure 4** for rear mounting bracket installation. If 3/8" bolt doesn't fit through clamp supplied with cover, the hole in the clamp might need to be enlarged with a 7/16" drill bit.
9. Tighten front and rear locker casting bolts using 1/4" hex drive. (If installing Nylon Locker Castings, torque bolts to 27 ft-lb)

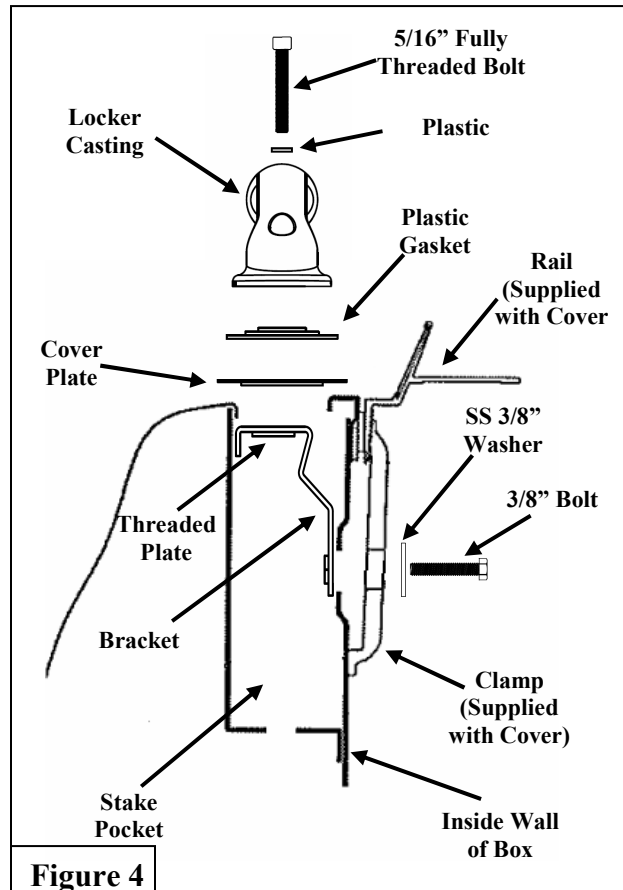

Tool Box Locker Rail Installation without Diamond Donut

See Putco catalog or contact Putco for the "Diamond Donut" option to mount your rails directly to the side of your toolbox.

1. Place a casting, without the bolt, gasket, expander or back plate, into the open end of the tube.
2. Place assembled tube onto truck by inserting the cover plate and bracket of the assembled casting into the rear stake pocket.

3. Center the front casting, left to right, on your truck's bed rail near the toolbox.
4. Mark the center of the hole in the casting on your truck's bed rail.
5. Using your drill and 5/16" drill bit, center the drill bit on the mark you made from Step 4 above and drill straight through the bed rail of your truck.
6. Place the casting assembly back onto the bed of your truck, again by placing the cover plate and bracket into the rear stake pocket refer to step 5 of the normal Locker Rail Instructions.
7. At the front casting, place a 5/16" bolt through the casting, oval gasket and the hole you drilled in Step 5. Place the expander block on the bolt and turn on a threaded plate and tighten with 1/4" hex drive.
8. Repeat the steps in this section for other side.