

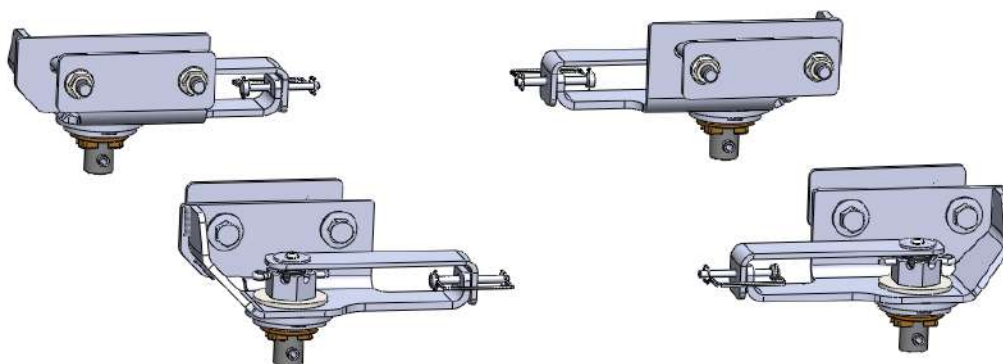

CHEVY / GM #4449 OE Puck Mounting Bracket Kit for SuperGlide #2700 & #2900



Gross Trailer Weight (Maximum) 18,000 lbs.
Vertical Load Weight (Max. Pin Weight) 4,000 lbs.

SYSTEM TOW CAPACITY

Please note, in order to determine the total tow capacity of a system, you must consider the weight ratings of each component in that system. This includes, but may not be limited to, the capacity/rating of the tow vehicle, the fifth wheel hitch, and the hitch's mounting system. Actual tow capacity of the system will be equal to the lowest rated component.

Installation Instructions

SPECIFICATIONS

- Fits 2016-2019 CHEVY/GM trucks with the OE 5th wheel hitch puck system
 - Attaches to Superglide models #2700 and #2900
 - Custom Mounting Bracket Kit (Bracket & Hardware) #4449

TABLE OF CONTENTS



MOUNTING KIT EXPLODED VIEW / MOUNTING KIT PARTS LIST.....3
ATTACHING KIT TO HITCH4
BUILDING THE POST ASSEMBLY.....5
INSTALLING HITCH INTO THE TRUCK BED.....6-7

PARTS LISTING FOR KIT

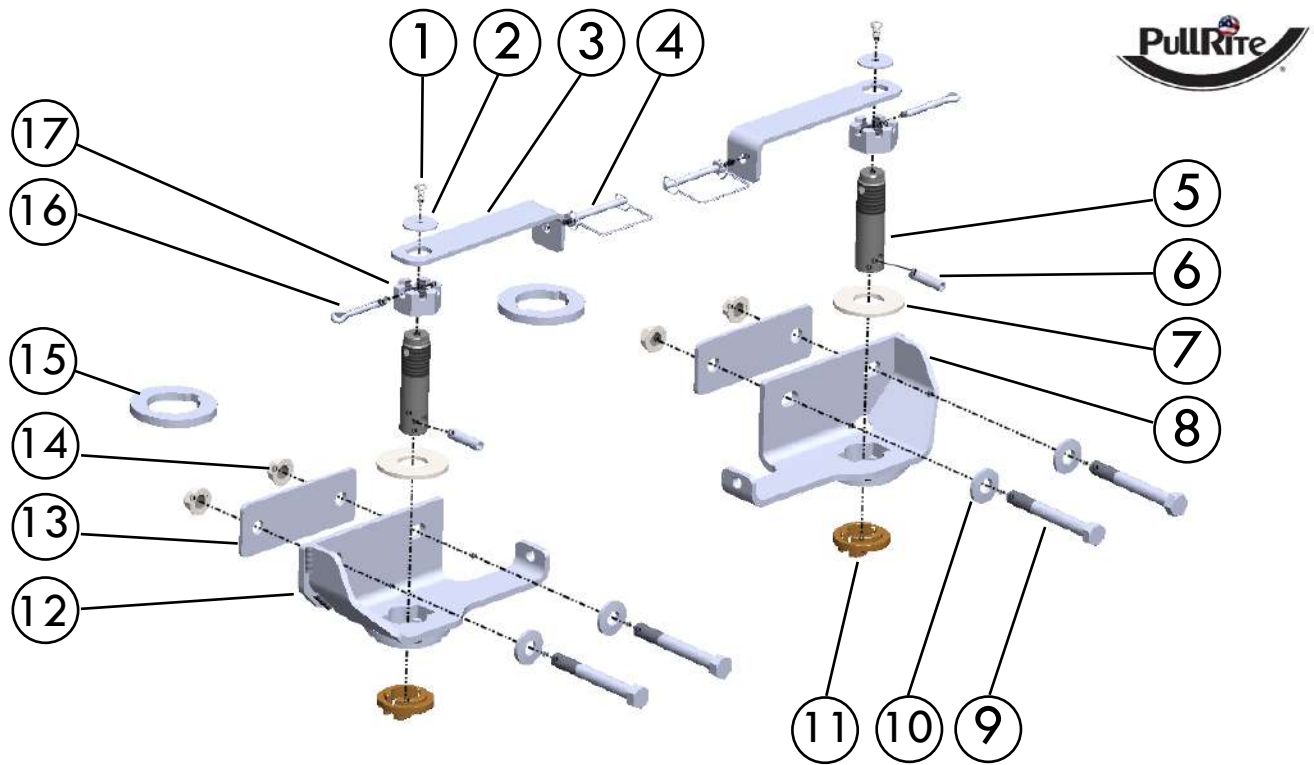

	Description	Part Number	QTY
1	BUTTON HEAD SOCKET CAP SCREW 1/4"-20 X 1/2"	98410241	4
2	OVERSIZED FLAT WASHER 1/4"	98250150	4
3	LOCK HANDLE	44480602	4
4	BAIL PIN	98410529	4
5	OE FOOT POST	44480701	4
6	SLOTTED SPRING PIN 3/8" X 1 3/4"	98410524	4
7	BASE WASHER - USS FLAT WASHER 1"	98250100	4
8	GM OE DRIVER SIDE REAR BRACKET	44490301	1
*	GM OE PASSENGER SIDE REAR BRACKET (OPPOSITE SIDE, NOT SHOWN)	44490401	1
9	HEX BOLT 1/2"-13 X 4"	98010191	8
10	CONICAL SERRATED WASHER 1/2" ID X 1-1/4" OD	98200172	8
11	BRASS PUCK WASHER	13070001	4
12	GM OE DRIVER SIDE FRONT BRACKET	44490101	1
*	GM OE PASSENGER SIDE FRONT BRACKET (OPPOSITE SIDE, NOT SHOWN)	44490201	1
13	BACKER PLATE	44490105	4
14	SERRATED FLANGE NUT ZINC PLATED 1/2"-13	98150201	8
15	PASSENGER SIDE SPACER PLATE	44490501	2
16	COTTER PIN ZINC PLATED 1/4" X 2"	98410567	4
17	CASTLE NUT PLAIN 1"-14	98150121	4

ATTACHING KIT TO HITCH

Be aware when attaching brackets, each one is different and unique to its place on the hitch base. Note the direction of the lock handles and that passenger side bracket post holes are larger.

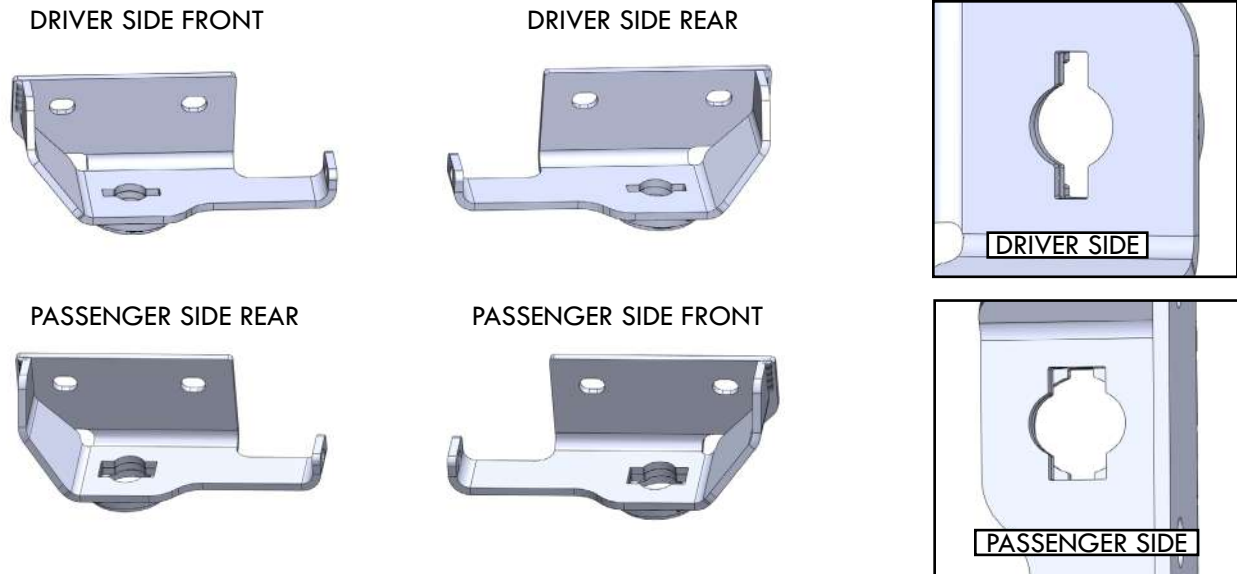

1. Place the brackets on the #2700 or #2900 SuperGlide base with Backer Plates and attach each using (2) 1/2-13 X 4 Hex bolts, (2) 1/2"-13 serrated flange nuts, and (2) Conical serrated washers (place serrated teeth facing the bracket). Place all brackets starting at the 3rd hole from the rear (tailgate) end on the SuperGlide base.
2. Hand tighten all hex bolts at this point. Keep them a little loose for an easier Install.

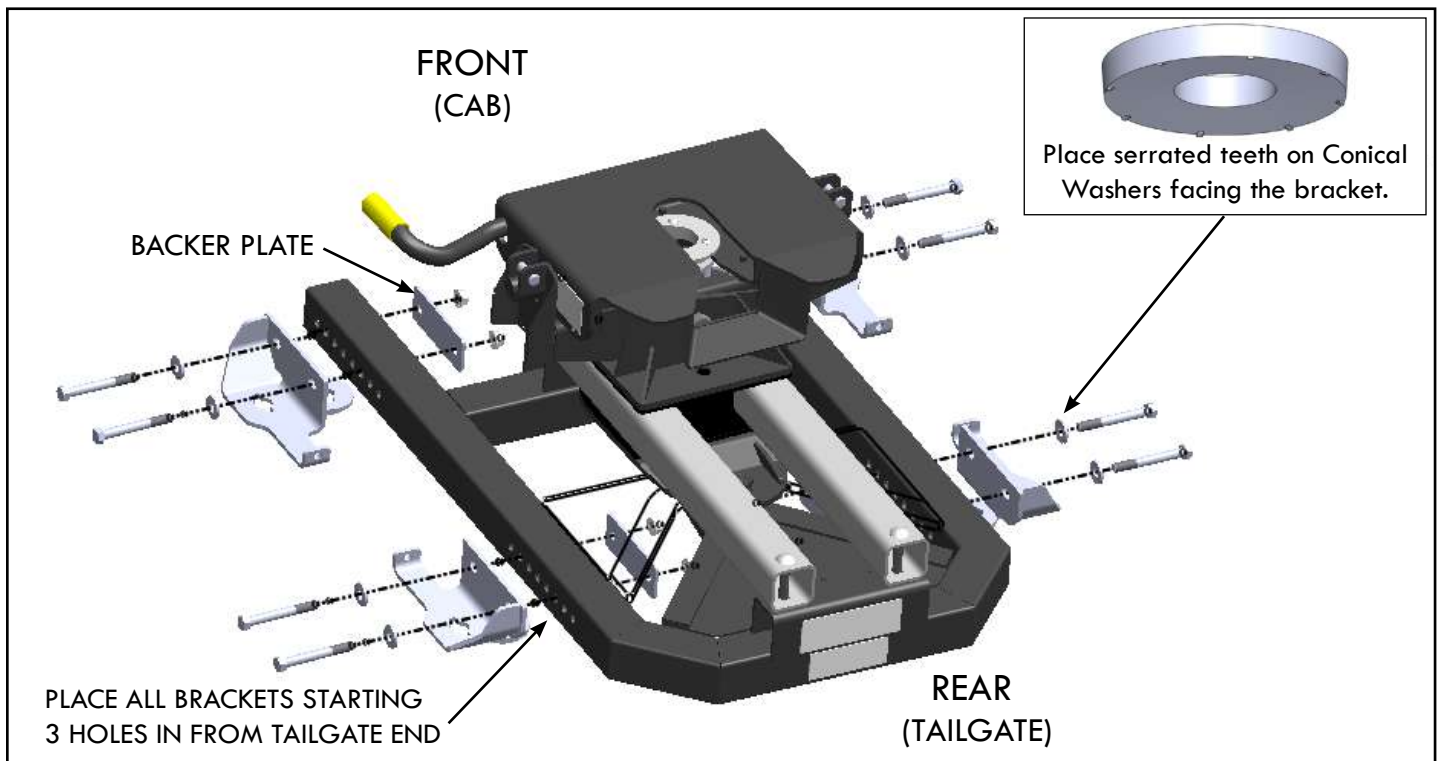

BUILD THE POST ASSEMBLY

Build the (4) post assemblies used for clamping hitch to the bed of the truck.

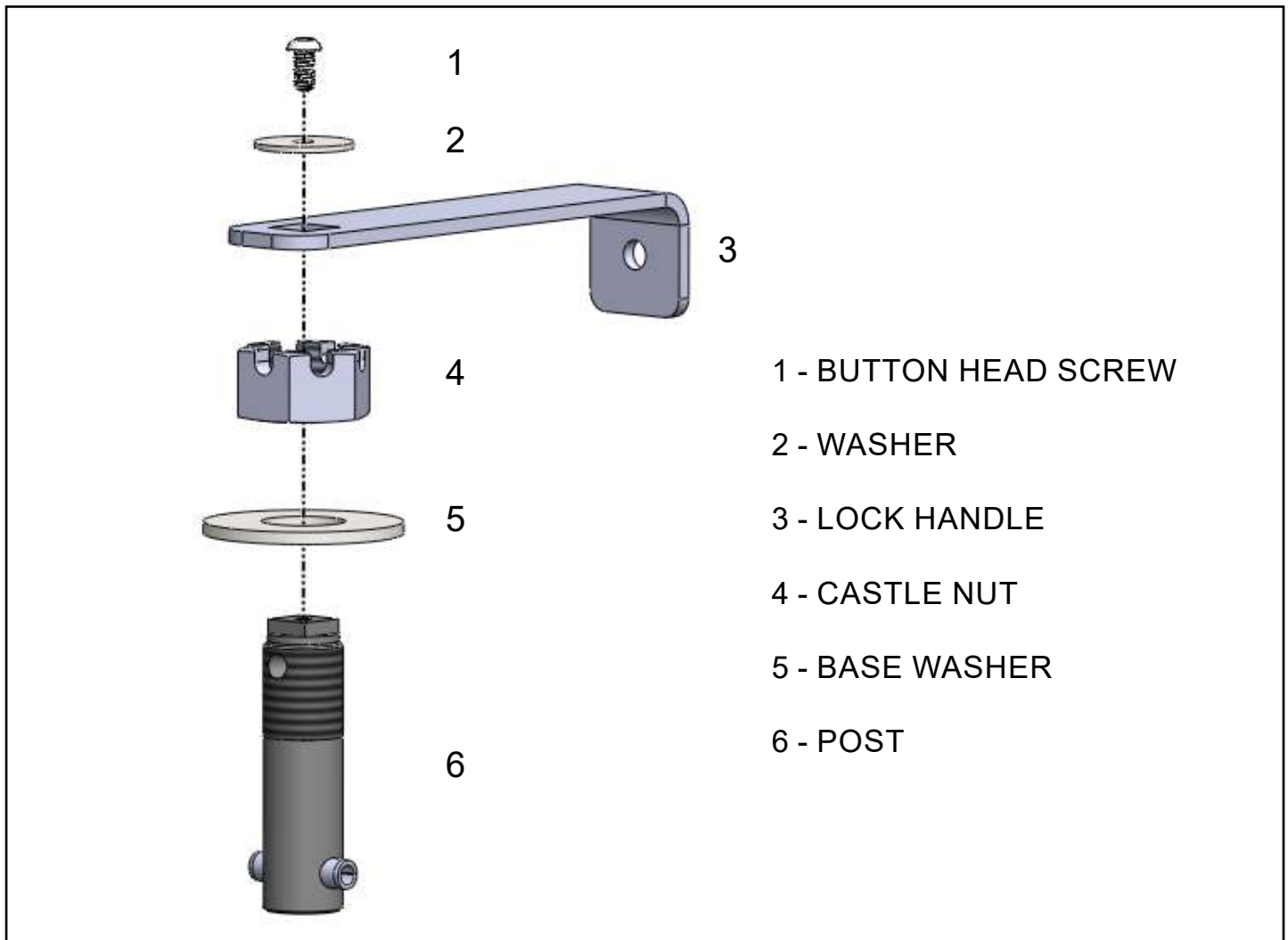

1. Place the Base Washer down on the Post.

2. Thread Castle Nut onto the Post.

3. Take the Lock Handle and place on top of the Post, the handle cut-out fits down over square top on Post. Add the Washer and Button Head Screw and tighten with an 3/16 hex key.

INSTALLING THE HITCH

FIG.1

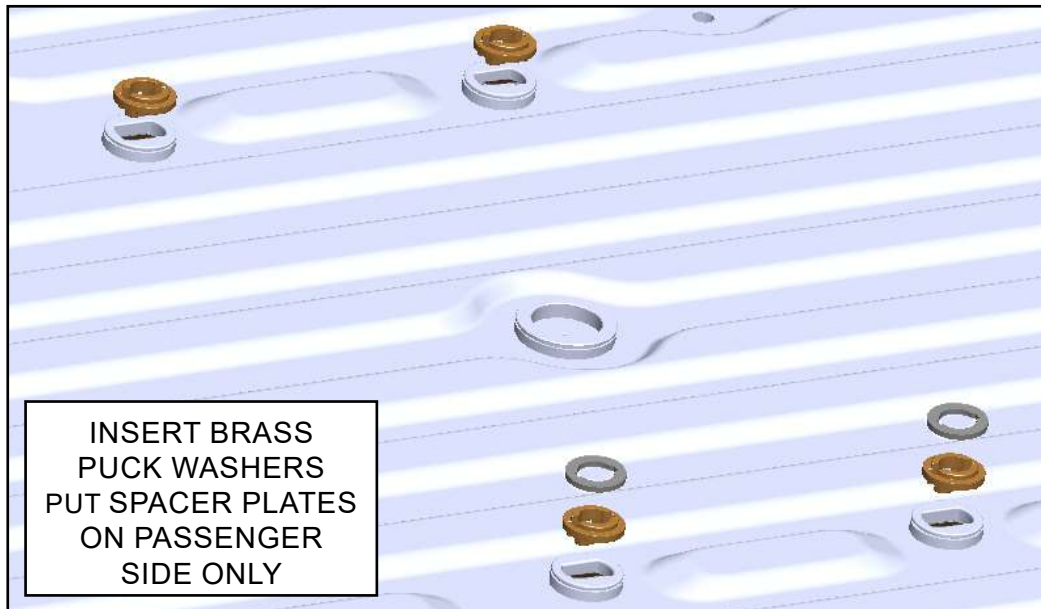

1. Place the (4) Brass Puck Washer in the OE pucks on truck bed (FIG.1). They should easily fit into the puck. In some instances, It may be necessary to lightly file the Brass Puck Washers to get them to fit as puck tolerances may vary. For the Passenger side, make sure to use Spacer Plates between Brass Puck Washer and bracket
2. Place the hitch over the seated Brass Puck Washers.They should all be visible through the post holes.
3. Starting with the driver side, take a Post Assembly and insert into the Brass Puck Washer in an open position as shown (FIG.2). Press and turn 90 degrees inward to the Lock Tab. At this point, tighten the Castle Nut on the Post Assembly just a few turns until it is firm.

FIG.2

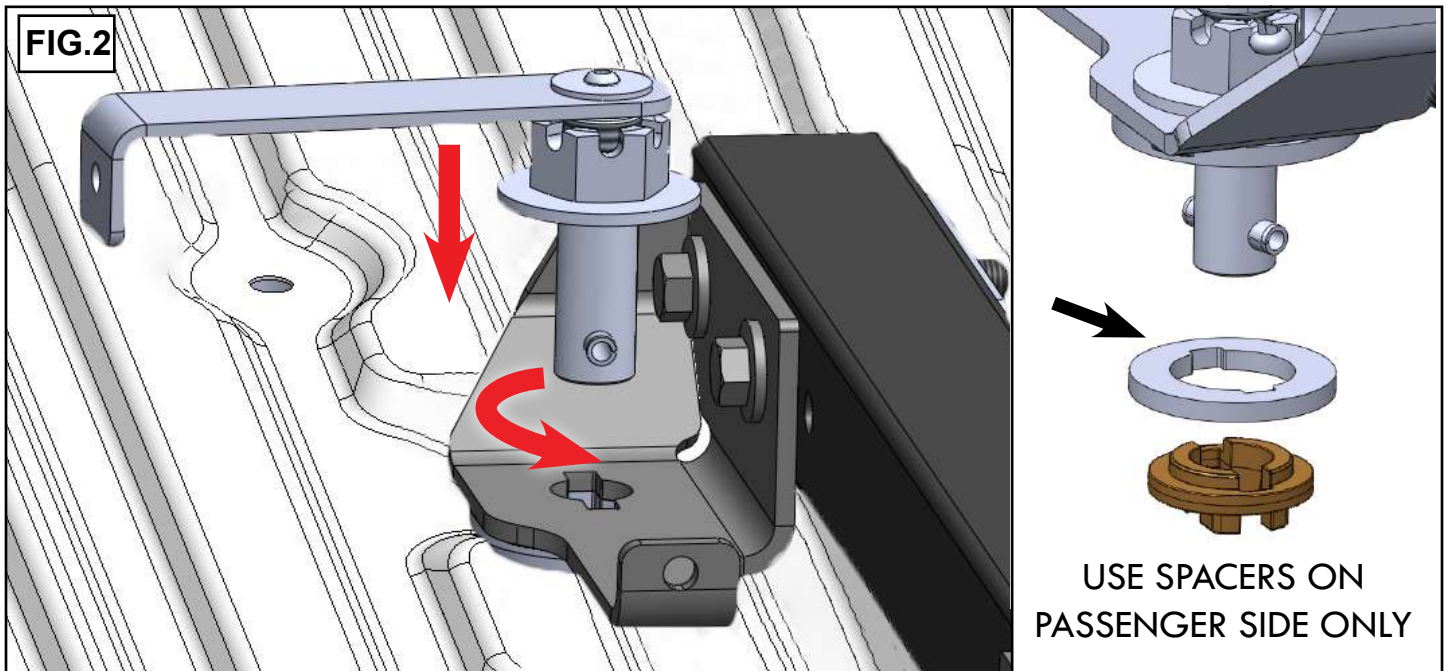

INSTALLING THE HITCH

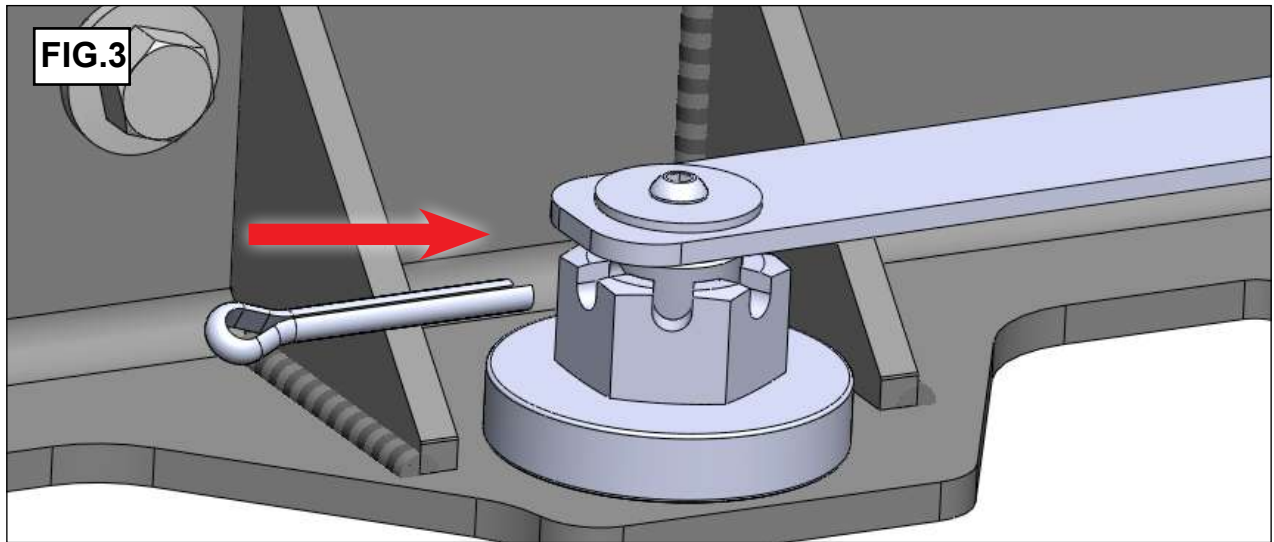

4. Feed the Cotter Pin through the Castle Nut and pre-drilled hole in the side of the Post (FIG.3). Bend ends of cotter pin to prevent it from sliding out. Repeat this step with the other Post Assemblies.
5. Align Lock Handles with hole in the Lock Tab (FIG.5). and place Bail Pins through each hole, snap bail pin to lock.
6. Tighten all 1/2"-13 X 4" Hex Bolts to 75 foot pounds.

