



OWNER'S MANUAL



#2700 (16K) Industry Standard SuperGlide

Gross Trailer Weight (Maximum) 16,000 lbs.
Vertical Load Weight (Max. Pin Weight) 4,000 lbs.



#2900 (18K) Industry Standard SuperGlide

Gross Trailer Weight (Maximum) 18,000 lbs.
Vertical Load Weight (Max. Pin Weight) 4,500 lbs.



#2300 (24K) Industry Standard SuperGlide

Gross Trailer Weight (Maximum) 24,000 lbs.
Vertical Load Weight (Max. Pin Weight) 6,000 lbs.

The following instructions provide valuable information regarding the function and proper use of the SuperGlide Fifth Wheel Towing System.

YOU MUST COMPLETELY READ THE INSTRUCTIONS WITHIN THIS MANUAL, PRIOR TO OPERATING THE HITCH TO PREVENT UNNECESSARY DAMAGE TO THE HITCH, VEHICLE, OR TRAILER.

TABLE OF CONTENTS

SYSTEM WEIGHT RATING vs. COMPONENT WEIGHT RATING.....	1
HOW DOES THE SUPERGLIDE WORK?	2
CAUTION	3
TESTING CLEARANCE	3
BASE RAIL FOOT ASSEMBLY.....	4
INSTALLING THE BASE RAIL FEET	4
LUBRICATION	6
MAINTENANCE	6
HITCH LUBRICATION	6
FIFTH WHEEL PLATE & KING PIN	7
FIFTH WHEEL PLATE OPERATION.....	8
HITCHING	10
SAFETY CHECKS	11
UNHITCHING.....	11
ADJUSTING THE TURNTABLE CAM ARM ASSEMBLY.....	12
CHALLENGE VS. SOLUTION	13
FREQUENTLY ASKED QUESTIONS	14
#2300 PARTS SECTION	16
ILLUSTRATION — #2300 EXPLODED VIEW	16
#2300 PARTS LIST	17
#2900 PARTS SECTION	18
ILLUSTRATION — #2900 EXPLODED VIEW	18
#2900 PARTS LIST	19
#2700 PARTS SECTION	20
ILLUSTRATION — #2700 EXPLODED VIEW	20
#2700 PARTS LIST	21

SYSTEM WEIGHT RATING vs. COMPONENT WEIGHT RATING

A towing system includes each vehicle and component involved in towing. Each item in your towing system has a capacity or weight rating. Your trailer has a Gross Vehicle Weight Rating, or GVWR. Your truck has a tow capacity, payload capacity, and possibly more. In addition, your fifth wheel hitch has a weight rating. This weight rating must be at, or above, the GVWR of your trailer for you to tow safely. In addition, if your truck can tow larger loads (has a larger capacity) than the rating of your hitch, your system is only safe to tow loads at the lower rating, that of the hitch.

Your mounting kit also has a weight rating, just like your fifth wheel hitch. Many times, these ratings are designed to match. But, this is not always the case. Your mounting kit may be higher rated than your fifth wheel hitch, but it also could be lower depending on the components involved. **The lowest rating of any one component in the system becomes the rating of the entire system.** If your mounting kit is rated to 18,000 lbs., and your hitch is rated at 24,000 lbs., the weight rating of the entire system will not be above 18,000 lbs. Other components in the system could lower the actual system rating further.

It is the end user's responsibility to ensure a safe towing experience. To this end, it is your responsibility to ensure that the truck, trailer, hitching components, and all other items involved are rated or have a capacity sufficient for the loads involved.

HOW DOES THE SUPERGLIDE WORK?

The SuperGlide is an automatically sliding Fifth wheel hitch based on a mechanical, cam action. Other sliding hitches on the market today require you to get in and out of the vehicle multiple times before and after a turn, throwing levers to allow it to move back and forth. The cam action of the SuperGlide hitch is truly automatic. When installed in your short bed truck and used in conjunction with our Capture Plate, the SuperGlide “glides” along the Way Tubes with ease, making turns automatically, without you having to ever get out of your vehicle. Here’s how it works:

Equipping your trailer’s king pin box with one of our Capture Plates (required for the hitch to function properly and sold separately), restricts the king pin on your trailer from turning in the Fifth wheel plate on the SuperGlide (#3601 pictured with a #3317 Capture Plate). Once the truck begins to make a turn, the “captured” Fifth wheel plate forces the large roller of the turntable cam arm assembly to rotate and roll along the path of the cam slot to begin the turn. This action pulls the plate and turntable assembly, with trailer in tow, away from the cab of your truck. The more you turn, the more it moves back.

It is important to note that the width of the trailer and the location of the king pin in relation to the “nose”, or leading edge of the trailer, is *critical* in determining if your truck and trailer are compatible to be used with a SuperGlide. Short bed trucks have only so much room from cab-to-axle; if your king pin is located too far under the nose of the trailer, the cam action of the SuperGlide may not move the trailer back fast enough to allow the necessary clearance.

Another important point in the use and maintenance of your SuperGlide is the need to lubricate the moving parts. SuperGlide hitches manufactured after November 2009 are equipped with Plastic Wear Plates and require a light oil application to enhance the movement of the Turntable Cam Arm Assembly on the Way Tubes.

The #2700, #2900 and #2300 SuperGlides are equipped with Plastic Wear Plates on the Turntable/Cam Arm Assembly to eliminate the need for constant lubrication between the metals of the Turntable and the Way Tubes. It is important to protect the Plastic Wear Plates from possible damage by keeping the Way Tubes free from rust and corrosion by applying a coating of light oil on the Tubes and the Turntable Shaft.

BEFORE OPERATING YOUR SUPERGLIDE HITCH, YOU MUST READ THE “LUBRICATION” SECTION. IF YOU HAVE ANY QUESTIONS REGARDING LUBRICATION OR HOW THE SUPERGLIDE FUNCTIONS, PLEASE CONTACT OUR CUSTOMER SERVICE DEPARTMENT.

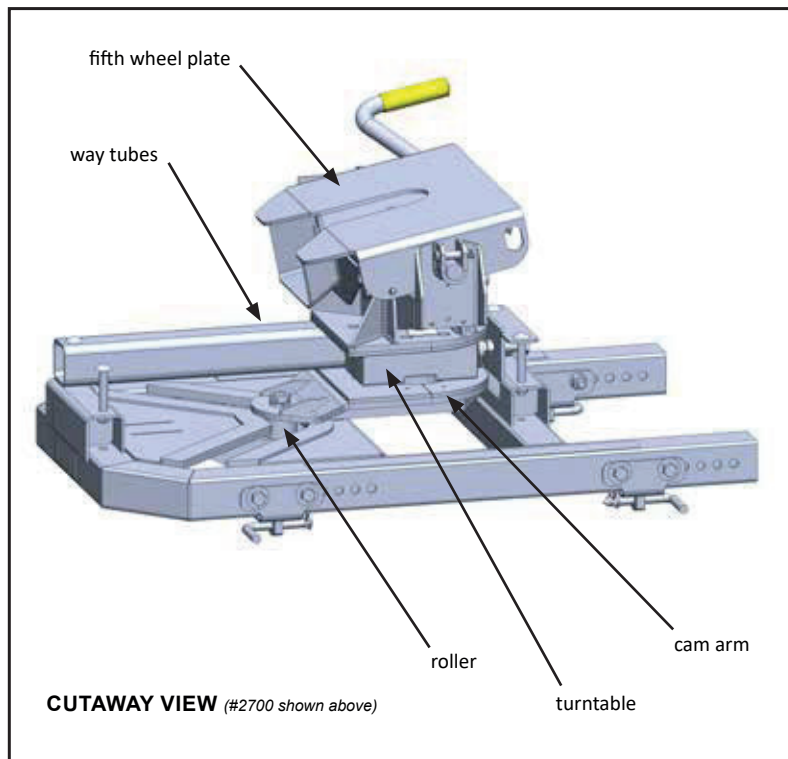
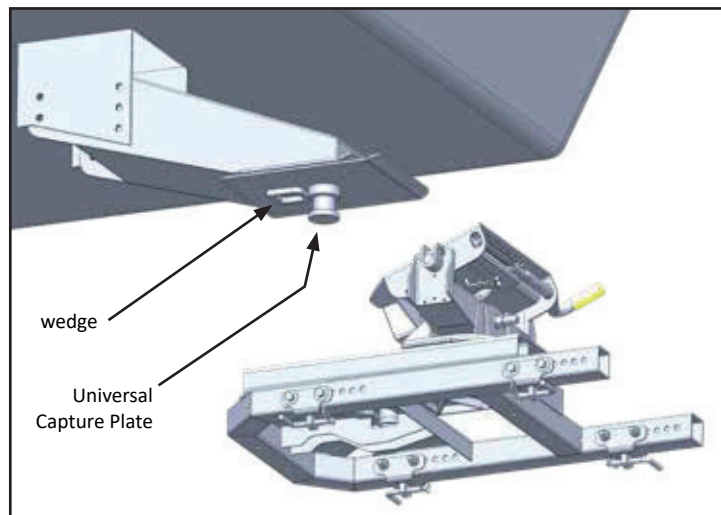

CAUTION

- The width of the trailer and the location of the king pin in relation to the “nose” (Dimension A), or leading edge of the trailer, is *critical* in determining if your truck and trailer are compatible to be used with a SuperGlide. If your king pin is located too far under the nose of the trailer, the cam action of the SuperGlide may not move the trailer back fast enough to allow the necessary clearance. Call PullRite Customer Service with trailer width, make and year of truck, and the distance of the king pin from the leading edge of the trailer (Dimension A).
- Using a trailer that has a long rear slope to the king pin box hangar, “B”, may cause damage to the king pin box or the inside edge of the truck bed. Dimension “B” must be less than one half the width of the inside top edges of the bed during turns for proper clearance.
- The SuperGlide hitch is equipped with a side-to-side pivot feature. There should be a minimum of 6” between the truck bed rails and the under side of the trailer for side tilt clearance. It is the customers responsibility to adjust the trailer king pin box for the appropriate amount of clearance depending on the terrain being traveled (example: some State Parks are sloped and unpaved; some driveways are steeply angled). If after-market bed covers are added, care must be taken to allow for additional clearance.
- The SuperGlide hitch is designed to allow you to make a 90 degree turn. Please use extreme caution when turning this far. In addition to putting stress on the wheels and axles of your trailer, if you make a turn greater than 90 degrees the trailer will contact your truck and you WILL damage various parts of the hitch which will NOT be covered under the Manufacturers Warranty.
- Position your brake-away cable so the slack in the cable will not be allowed to catch on the hitch during turns or lodge in the cam mechanism. Failure to modify the length may cause the cable to catch on protruding parts of the hitch which could activate the trailer brake, causing damage to the truck, trailer or hitch. Resulting damages will not be covered by warranty.
- Position or coil any slack in your 7-way electrical cable out of the way of your moving hitch. It is preferred that the plug and cabling remain isolated rearward of the hitch (nearest the tailgate) to prevent damage. Make slow test turns while observing the 7-way cable until you are satisfied that it will not become caught in the hitch mechanism.
- **FOREIGN DEBRIS:** Anything carried in the bed of your truck during towing will need to be well secured. Remove any foreign debris that might move around in the bed and contact the hitch. ***This will help to ensure that nothing will get caught in or jam the movement of the cam which can cause damage to the hitch.***

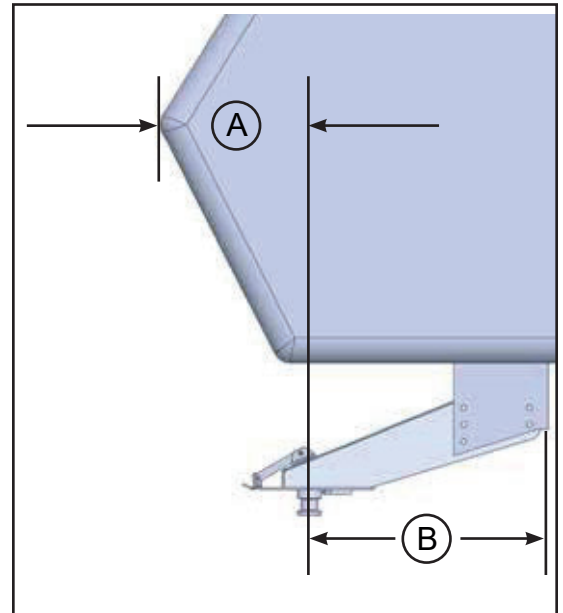

TESTING CLEARANCE

When you are assured your trailer is safely hooked up, pull forward and slowly start to turn. Make sure that someone is outside watching the distance between the cab and the trailer. The distance between the cab and trailer should be greater than two inches at all points of the turn. Specifically watch the distance when the corner of the trailer is closest to the cab and also when nearing a 90 degree turn. The minimum two inches of clearance is needed for normal driving conditions. The practice of testing clearance will let you know how much clearance you actually have should you encounter adverse road conditions.

Example: It is possible for the trailer to hit the cab when turning through a dip where the corner of the trailer is closest to the cab or when nearing a 90 degree turn.

BASE RAIL FOOT ASSEMBLY

The Industry Standard SuperGlides are equipped with base feet that must be attached to the base rails by the installer prior to mounting the adjustable base unit.

There are two groups of holes on each side of the base assembly that will allow you to move the Base Rail Foot Assemblies fore-to-aft, locating the trailer's king pin over the axle.

It is the responsibility of the installer and SuperGlide owner to position the base so the trailer does not come in contact with the cab during a turn.

Make certain that you have a minimum of two or more inches of clearance between the truck cab and trailer as they pass each other. A reasonable range of vertical movement will insure that when the truck and trailer are passing through areas of rough terrain and significant dips in the road, there is room for the trailer to "flex" without contacting the cab.

INSTALLING THE BASE RAIL FEET

1. Determine which hole setting on the base unit will position your king pin over the axle (see illustration below).
2. Secure the Base Rail Foot Assemblies, to the hole settings you have chosen on the base, with the $\frac{1}{2}$ " bolts, $\frac{1}{2}$ " flat washers and $\frac{1}{2}$ " nuts, loosely tighten.
3. Install the SuperGlide on the base rails already installed in the truck bed, making certain the feet are seated completely in the base rail slot.
4. Secure the Base Rail Foot Assemblies with the Hitch Pins and #9 Pin Clips provided in the SuperGlide package.

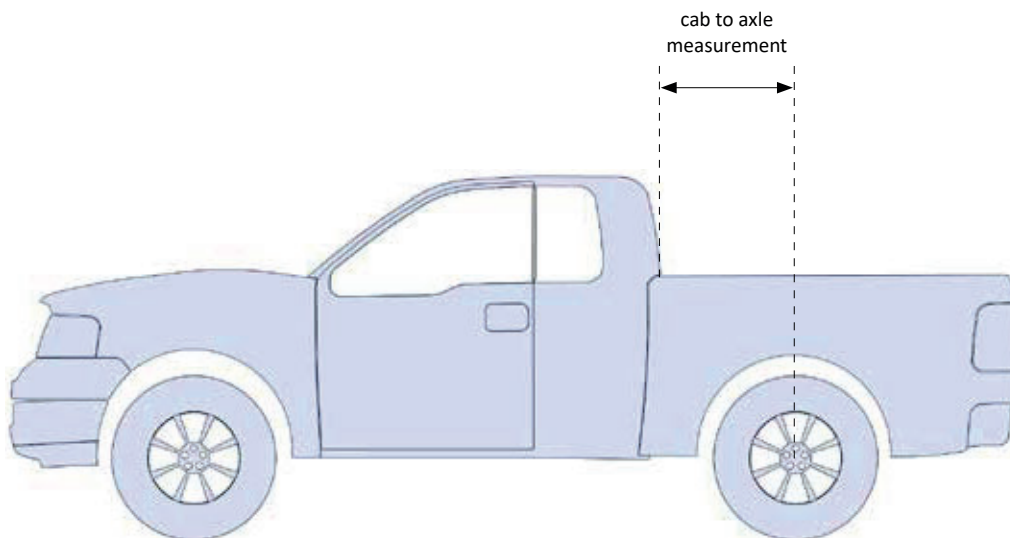

BASE RAIL FOOT ASSEMBLY

5. To minimize any forward and aft movement when towing, secure the feet as far apart, fore-to-aft, as the slot opening on the base rail will allow. If you still experience movement, consider loosening the base rail fasteners and tapping the base rails toward each other to achieve optimal positioning.
6. Torque the bolts to 75 ft. pounds.
7. An aftermarket, ½" Locking Hitch Pin, may be used in place of one or more of the standard Hitch Pin and Clips to prevent theft.

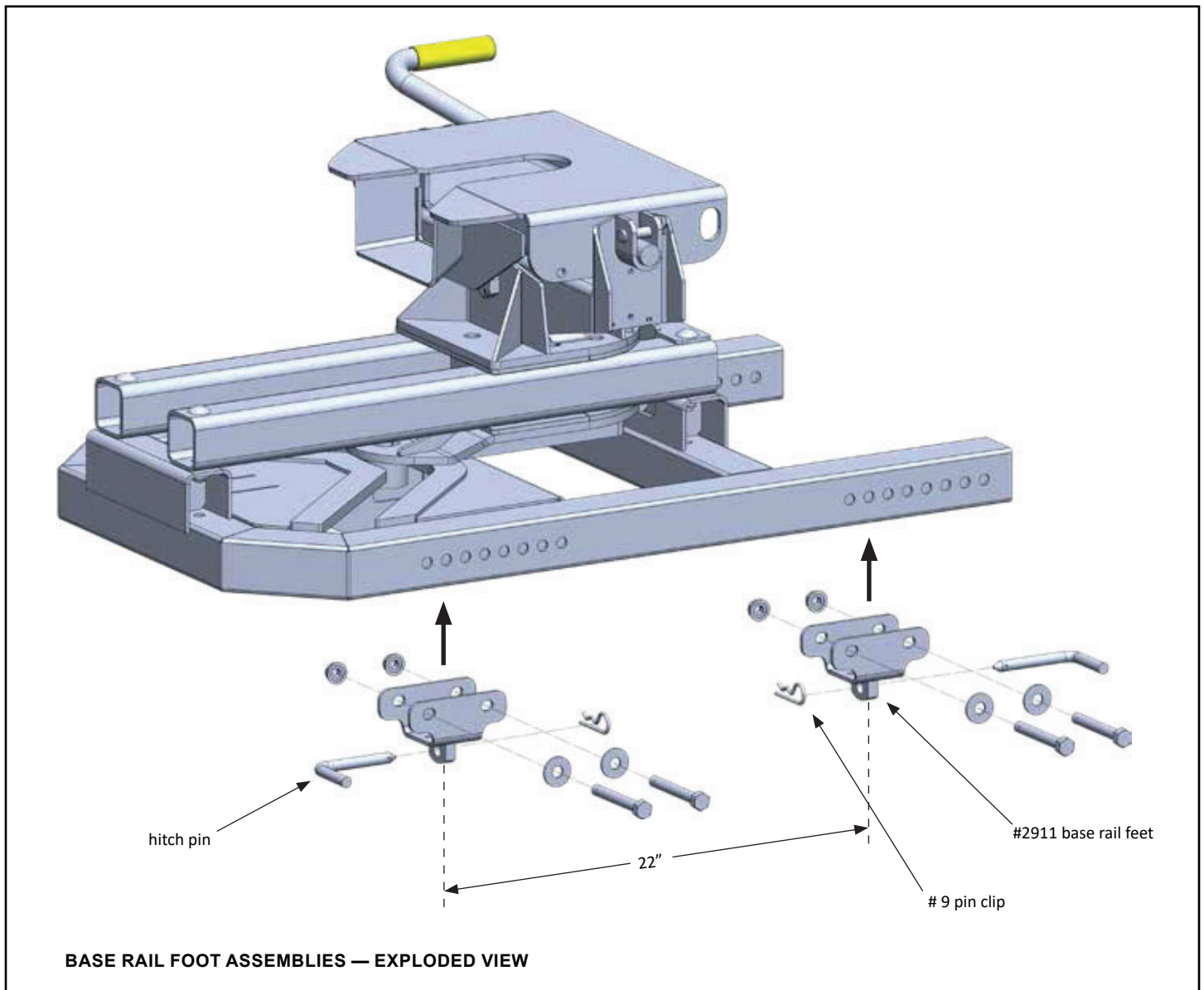

LUBRICATION

DO NOT OPERATE HITCH UNTIL YOU READ THIS SECTION!

The SuperGlide hitch was designed to allow the Turntable Cam Arm Assembly to “glide” along two metal tubes, called the Way Tubes. Since its release in 1998, we have made several advancements in the design, strength, and durability of these components. November 2009 brings a new innovation from PullRite Towing Systems with the use of plastics. The Turntable Cam Arm Assembly is now equipped with Plastic Wear Plates. It is imperative that you read each of the following sections so you can learn how to care for your hitch properly.

MAINTENANCE

Inspect all mounting bracket and hitch hardware, that it is securely fastened. The Fifth Wheel Plate should be removed and inspected, checking all moving parts for wear—clean as directed above. Inspect all mounting bolts periodically for tightness and general condition, and re-torque if necessary. 1/2” bolts to 75 ft. lbs., and 5/8” bolts to 150 ft. lbs.

#2300 and #2700 models utilize a castle nut and pin in the roller assembly. To re-torque, tighten roller bolt to a minimum of 125 ft. lbs., then tighten more until next nut slot aligns with the stud cotter pin hole. Install cotter pin and bend one leg upward.

When storing the SuperGlide hitch, you should be sure that the Fifth Wheel Plate parts and Way Tubes are lubricated with WD-40 to retard the formation of rust. Cover the entire assembly to prevent accumulation of dirt, grime, or rust.

HITCH LUBRICATION

Plastic Wear Plates

The Plastic Wear Plates of the SuperGlide’s Turntable Cam Arm Assembly were designed to glide along the surfaces without the need for heavy lubrication. To protect against rust and to enhance the ease of turning on the Way Tubes, a light oil (WD-40 or a 3-in-1 oil) should be applied to the Way Tubes’ top and inward facing sides and between the front and rear openings in the Plastic Wear Plates positioned around the Turntable/Cam Arm Shaft.

A light lubricant that is applied more frequently (each day of use) is preferred over the use of heavier lubricants. Since any applied lubricant is going to be “wiped” off by the sliding action of the hitch, a light lubricant applied more frequently will perform better (reduce the friction between the plastic and steel surfaces), and will be less messy, as well as attract less dust and dirt. Heavy grease will be “wiped” off just as fast as light lubricant pushing the heavy grease to areas that will not benefit the wear surfaces - only making it appear that the hitch is still well lubricated.

You will find with use, that the Plastic Wear Plate will wear the shiny zinc coating off the Way Tubes in areas, creating “bare” areas of the metal, as well as light scoring marks in areas of repeated use. This is normal, but will be protected as you apply WD-40 to the Way Tubes with each day’s use.

If your hitch is unused for more than a day or it is in storage, rust can form quickly in these areas. If rust does form, simply use steel wool or lightly sand those areas. Never let your tubes become pitted with rust, as it may cause the plastic to tear or catch on rough areas. The Plastic Wear Plate has a long life expectancy, but depending on how often, and what terrains you are traveling, the plastic will eventually, wear down with time. If the 1/4” plastic plate wears down to 3/16”, it should be replaced.

WARNING: Do not use any lubrication other than a light oil on the Way Tubes of your SuperGlide hitch. Using other lubricants, such as those with a silicone base, will create a residue and may hinder the functionality of the Turntable Cam Arm Assembly. Buildup of old oil and dirt can also create a residue over time and needs to be kept clean.

LUBRICATION

DO NOT OPERATE HITCH UNTIL YOU READ THIS SECTION!

1. WAY TUBES: Cover the tops and inside face of each Way Tube
2. TURNTABLE SHAFT: Using a directional straw attached to the spray nozzle, direct oil between the openings in the Plastic Wear Plates at both the front and rear
3. PIVOT BOLT AND ROCKER ARM: Inspect and lubricate the Pivot Bolt monthly with axle grease when heavily used, or annually with light use.
To remove the pivot bolt for lubrication:

- Remove the Fifth Wheel Plate {A} from the Rocker Arm.
- Remove the Hex Nut {C3} and Lock Washer {C4} from the Rocker Arm Pivot Bolt {C1}.
- Place downward force, compressing the Rocker Arm Spring, enabling the Pivot Bolt to be removed.
- Lube the Pivot Bolt generously with a quality axle grease and reinstall. Tighten the Pivot Bolt to the point where there is resistance when you move the Rocker Arm side-to-side.

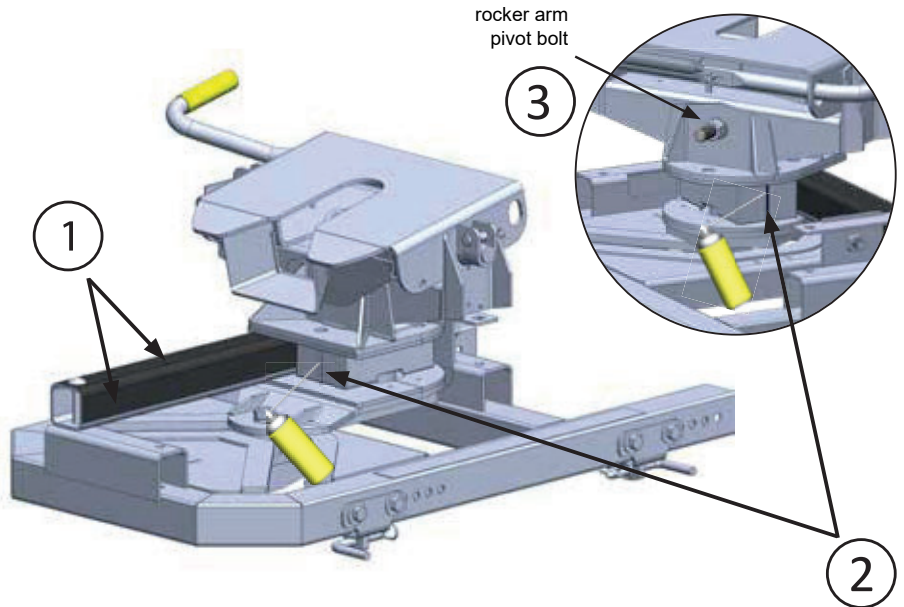

Passenger side Way Tube removed for illustrative purposes

4. HITCH PINS: A light coating of lubricant on the hitch pin and clips will help you install and reinstall them easily.

FIFTH WHEEL PLATE & KING PIN

The plate and its moving parts should be lubricated with a light lubricant such as WD-40 or 3-in-1 oil, before each trip or as needed. Be sure the plate is free of dirt and old oil buildup. Pull the Release Handle repeatedly so that the lubricant will spread among the moving parts that may not have otherwise been covered sufficiently.

Be sure the trailer's king pin is clean and free from rust. A light coating of WD-40 or other similar lubricant should be used on the king pin.

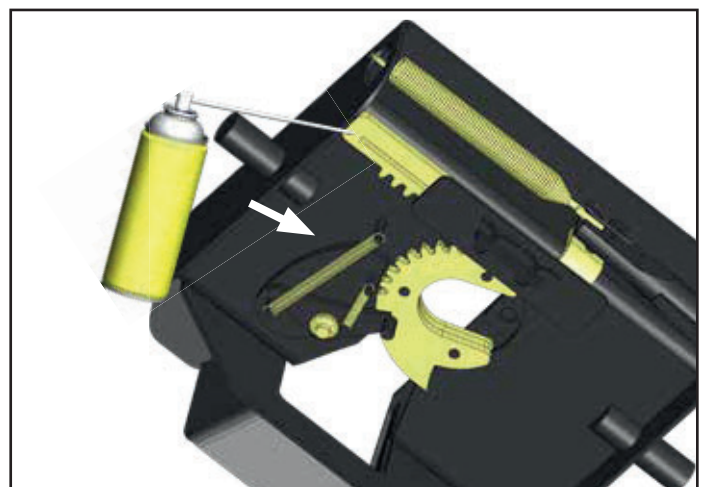

1901 plate

FIFTH WHEEL PLATE OPERATION

A better understanding of the plates locking and un-locking operation can be obtained by viewing the working parts from the underside of the plate (#3601 plate pictured below). The Fifth Wheel Plate {A} can be removed and turned over to view the workings of the mechanism. When operating the Fifth Wheel Plate manually, please be aware that the Lock Jaw Assembly has more movement capability when there is not a king pin present to center the assembly. Refer to the illustrations below for part identification.

1. To open the locking mechanism, lift and pull the Release Handle out until the Lock Catch engages the Lock Jaw Assembly (see illustrations on the opposite page).
2. As the trailer king pin moves into the plate, it will contact the Lock Lever, forcing the Lock Catch to disengage the Lock Jaw Assembly, allowing the Lock Bar Spring to close the Lock Jaw Assembly behind the King Pin. The King Pin must be fully engaged in the plate slot or the Lock Jaw Assembly will not seat properly, and the Handle Catch would not then engage the inner side wall of the plate. To be certain that the Lock Jaw Assembly has closed fully, attempt to pull the Release Handle without first lifting it.

NOTE: Please note that when lifting the handle to clear the side wall of the plate with the handle catch, it will be necessary to pull with some force to begin the Lock Jaw rotation. Merely lifting the Release Handle will not cause the Handle to “pop” open and rotate the Lock Jaw to the open position.

3. To discourage theft or pranksters, place a padlock through the obround hole *above* the Release Handle (see Illustration below; not available for #2900 and #2300 SuperGlide).

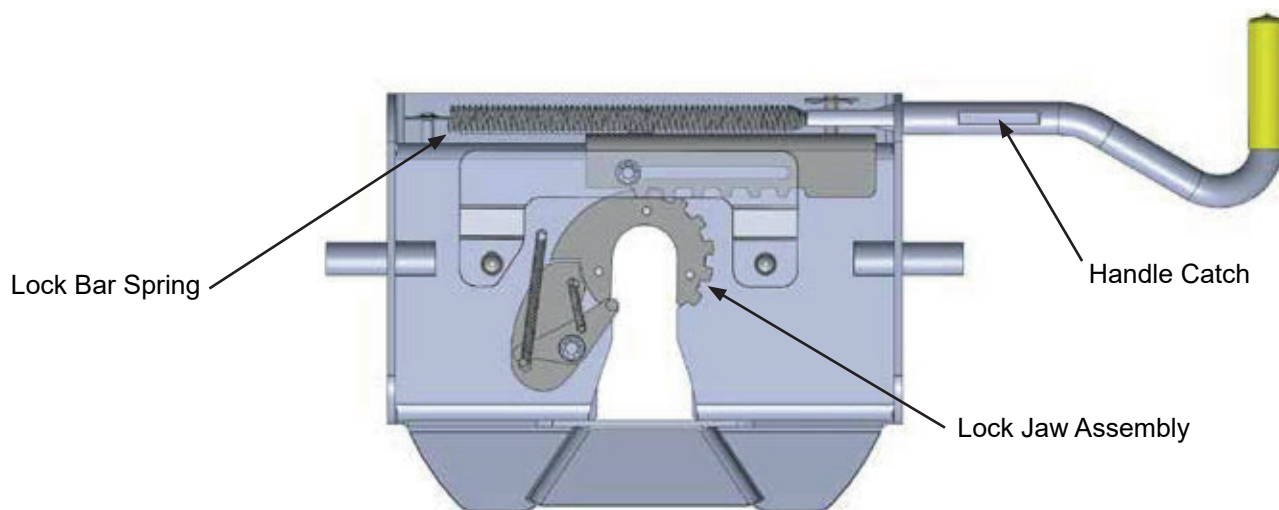

OPEN -- UNLOCKED POSITION

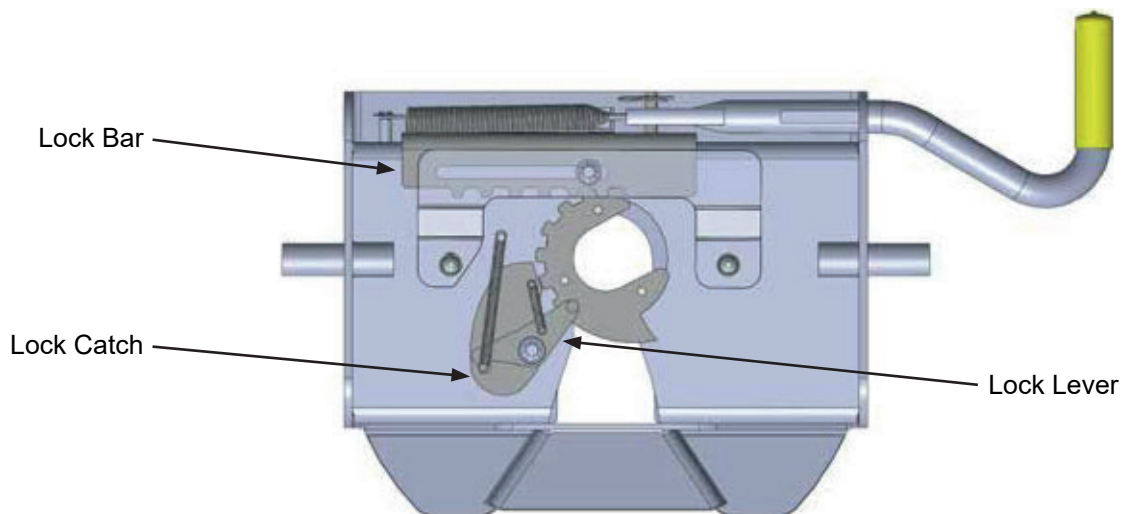

CLOSED -- LOCKED POSITION

FIFTH WHEEL PLATE OPERATION

CAUTION: DO NOT ATTEMPT TO TRIP THE LOCK MECHANISM WITH YOUR HAND. USE A PROBE DEVICE TO SIMULATE THE KING PIN ACTION

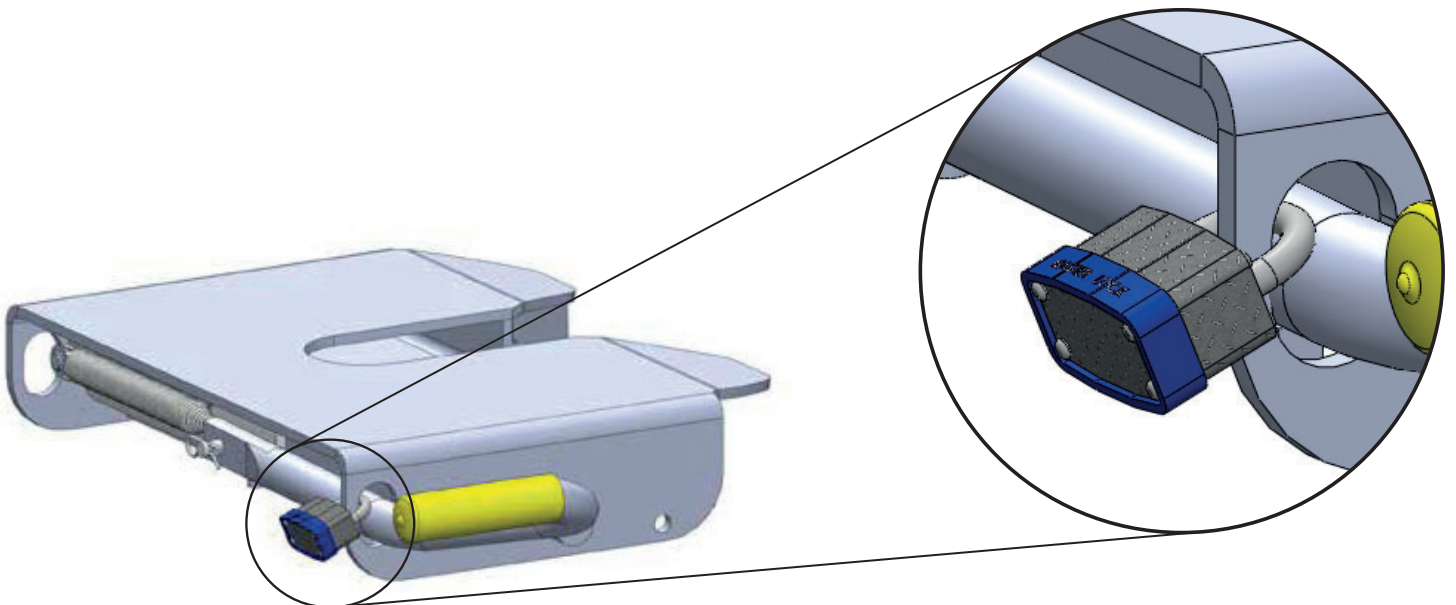
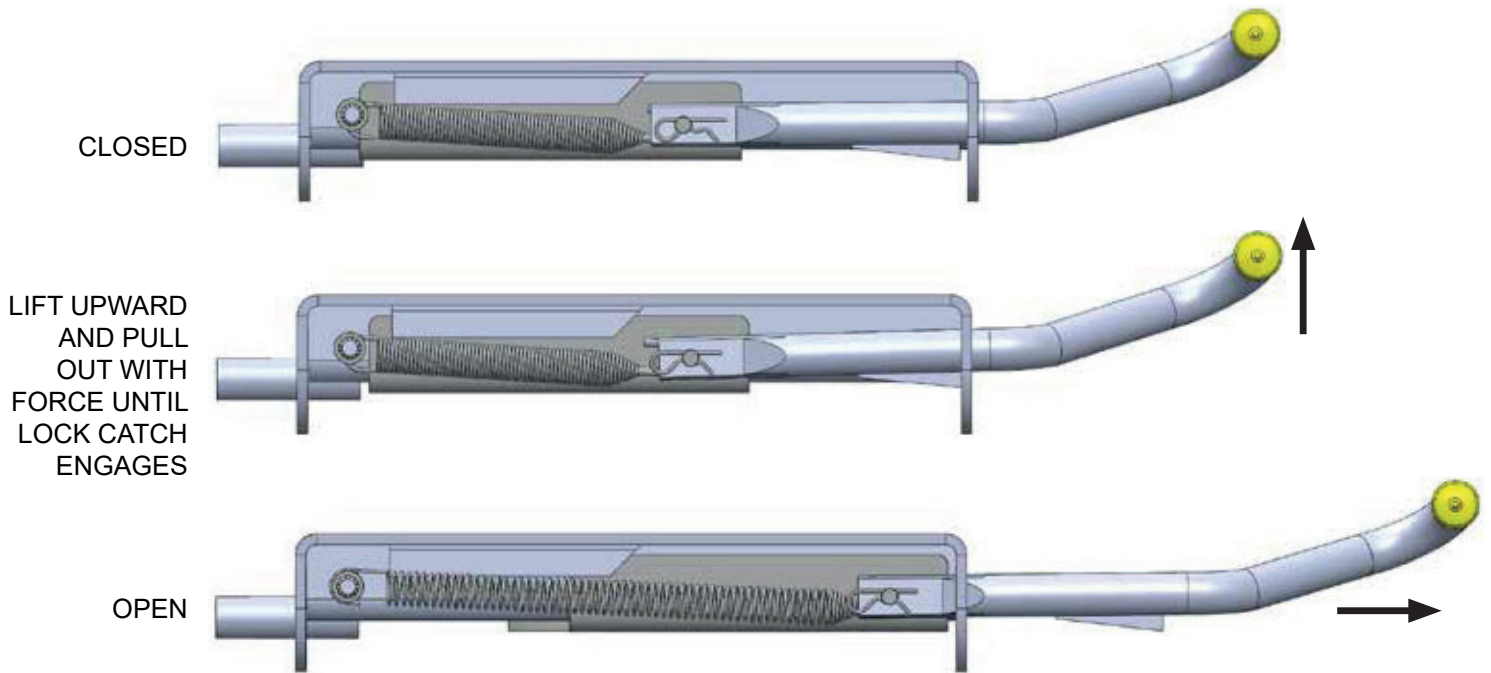

(feature available only on #2700 SuperGlide)

HITCHING

WARNING: Never perform any of the following actions while any part of a person is between the vehicle and trailer.

1. Align your truck with the center of the trailer. The truck should be close to parallel to the centerline of the trailer. Hitching can only be accomplished when the tow vehicle and the trailer are aligned within 10° of each other (see below).
2. Block the trailer wheels so the trailer will not roll back.
3. Lower your tailgate and back up until there is about 6" of clearance between the SuperGlide hitch and the end of the Capture Plate (sold separately and installed on your trailer's king pin plate). Raise or lower the front of the trailer so the bottom of the Capture Plate is aligned slightly above the beginning of the ramp area of the Fifth Wheel Plate. This procedure will cause the front edge of the Capture Plate to "ride up" the ramp and flatten or tilt the hitch plate into a parallel position.

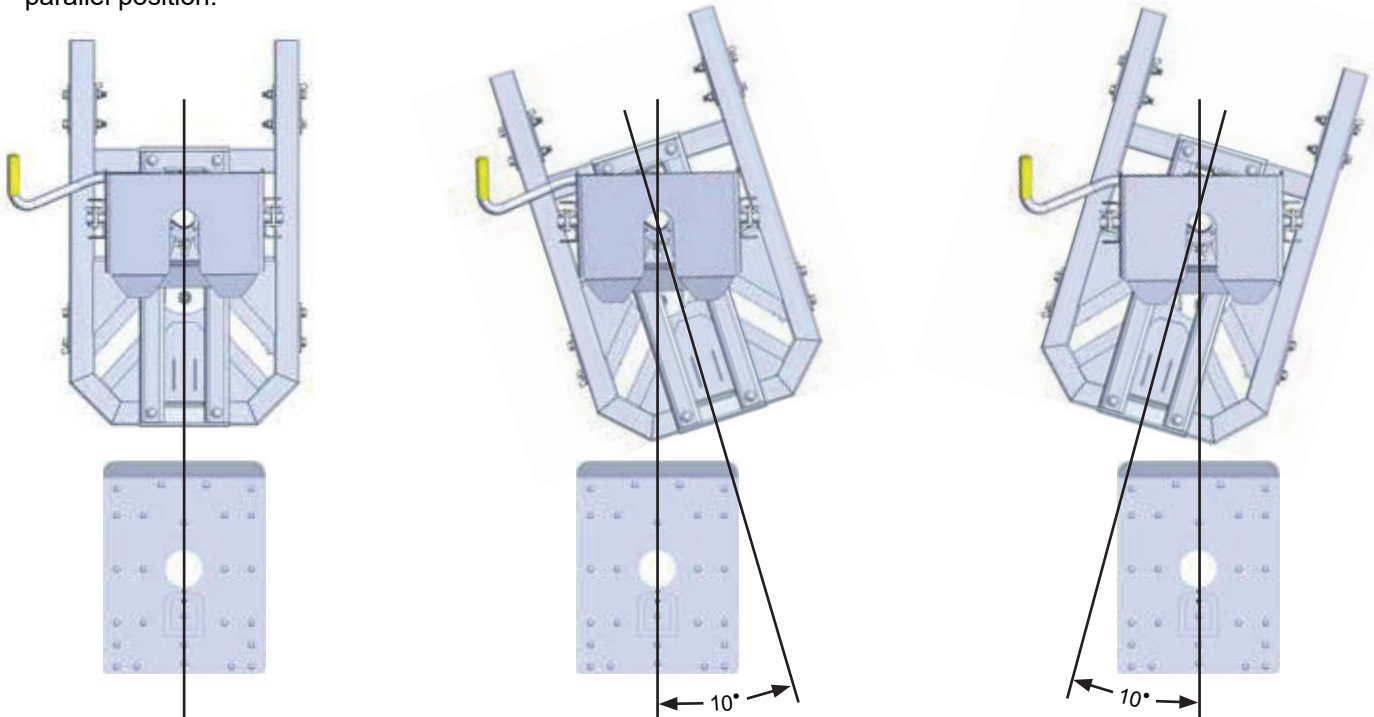

CAUTION: If this procedure is not followed, the king pin may bind in the plate mechanism and not lock-in properly. Following the procedure as outlined in Step 3 will ensure that you will not "high hook" the king pin in the plate. "High hooking" occurs when backing your hitch into a trailer that is set too high, resulting in the lower flange of the king pin to wedge itself against the metal edge of the lower horseshoe piece or against the Lock Jaw Assembly. Damage to the Lock Jaw Assembly may result and not allow smooth operation of the closing mechanism.

4. The Fifth Wheel Latch must be in the open position (see illustration on pg. 10). Lift and pull out on the Release Handle to open the Lock Jaw Assembly.

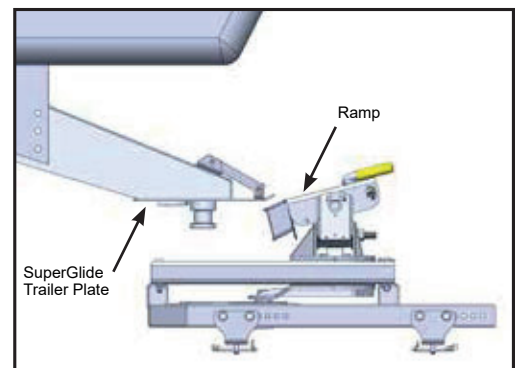

CAUTION: Damage will result should you attempt to hook up with the Lock Jaw Assembly in the closed position.

5. Back up the truck in one fluid motion, so the king pin enters the center of the Fifth Wheel Plate {A} opening.
6. Make sure the Lock Jaw Assembly is completely seated around the king pin.
7. Be sure that the Release Handle has fully returned to the closed position and proceed to "Safety Checks" on pg. 13.

SAFETY CHECKS

1. Shine a light on the Fifth Wheel Plate Lock Jaw Assembly making sure it has closed around the king pin.
2. Pull the Release Handle towards you without lifting it up. If the Lock Jaw Assembly is completely closed the Handle Catch will prevent you from being able to pull the Release Handle open.
3. Raise the trailer jack base plates just above the ground, lock your trailer brakes, then pull the tow vehicle slowly forward putting a strain on the trailer.
4. When you are assured that the trailer is safely hooked up, raise your trailer jacks into their full retracted position.

FAILURE TO PERFORM THESE SAFETY CHECKS MAY RESULT IN DAMAGES TO TRUCK AND TRAILER.

UNHITCHING

WARNING: Never perform any of the following actions while any part of a person is between the vehicle and the trailer.

1. Once you have the trailer located and are ready to unhitch, (unhitching can only be accomplished when the truck and trailer are aligned within 10 degrees of each other--see previous page), block the trailer wheels so it will not roll back or forward. Back into the blocked trailer slightly and set the parking brake while you are still in gear. This action will relieve pressure on the lock mechanism before attempting to release the latch mechanism.
2. Lower the trailer jacks to the point of just touching the ground but do not raise the trailer at this point.
3. Open the Lock Jaw Assembly by first lifting, then pulling the Release Handle towards you (see pgs. 10 & 11).
4. Lower the trailer jacks until the bottom of the king pin box is almost free of the top of the Fifth Wheel Plate {A}. Make certain that the bottom of the king pin is not so high that binding on the hitch Lock Catch would result.
5. After lowering the truck's tail gate, disconnect the trailer electrical cord and break-away switch cable, then pull forward.
6. As the king pin slides from the Fifth Wheel Plate, notice that the locking mechanism remains open once the king pin is removed.

CAUTION: If it should be necessary to reposition your trailer, you must follow the hitching procedures to ensure the hitch is latched before moving the trailer.

CAUTION: You may wish to keep the plate closed until you are ready to re-hitch to avoid injury or accidents to children or adults who attempt to operate the plate mechanism. **DO NOT ATTEMPT TO TRIP THE LOCK MECHANISM WITH YOUR HAND, USE A PROBE TO SIMULATE THE KING PIN.**

ADJUSTING THE TURNTABLE CAM ARM ASSEMBLY

This adjustment will need to be made periodically. If you are experiencing a bump or “clunk” when starting or stopping, or if the hitch is sliding up and down the way tubes when you are not hooked up to the trailer you can perform this adjustment to reduce the noise and keep the hitch in the forward towing position when not trailering.

1. The Turntable Cam Arm Roller {C2} needs to be kept snug against the rear edge of the of the Cam Slot (see below).
2. To adjust, loosen the Jam Nut located on the Threaded Stop Assembly {E1}, under the Fifth Wheel Plate {A} (on the side facing the cab of your truck).
3. Adjusting the Threaded Stop Assembly's hex-shaped plate, will remove excessive play from between the Cam Slot and the Turntable Cam Arm Roller.
4. Turn the hex-shaped plate of the Threaded Stop Assembly by hand, adjusting incrementally, until it is difficult to pull the Turntable/Cam Arm Assembly by hand, into the angled Cam Slot. While holding the hex-shaped plate in place, tighten the Jam Nut with a wrench.

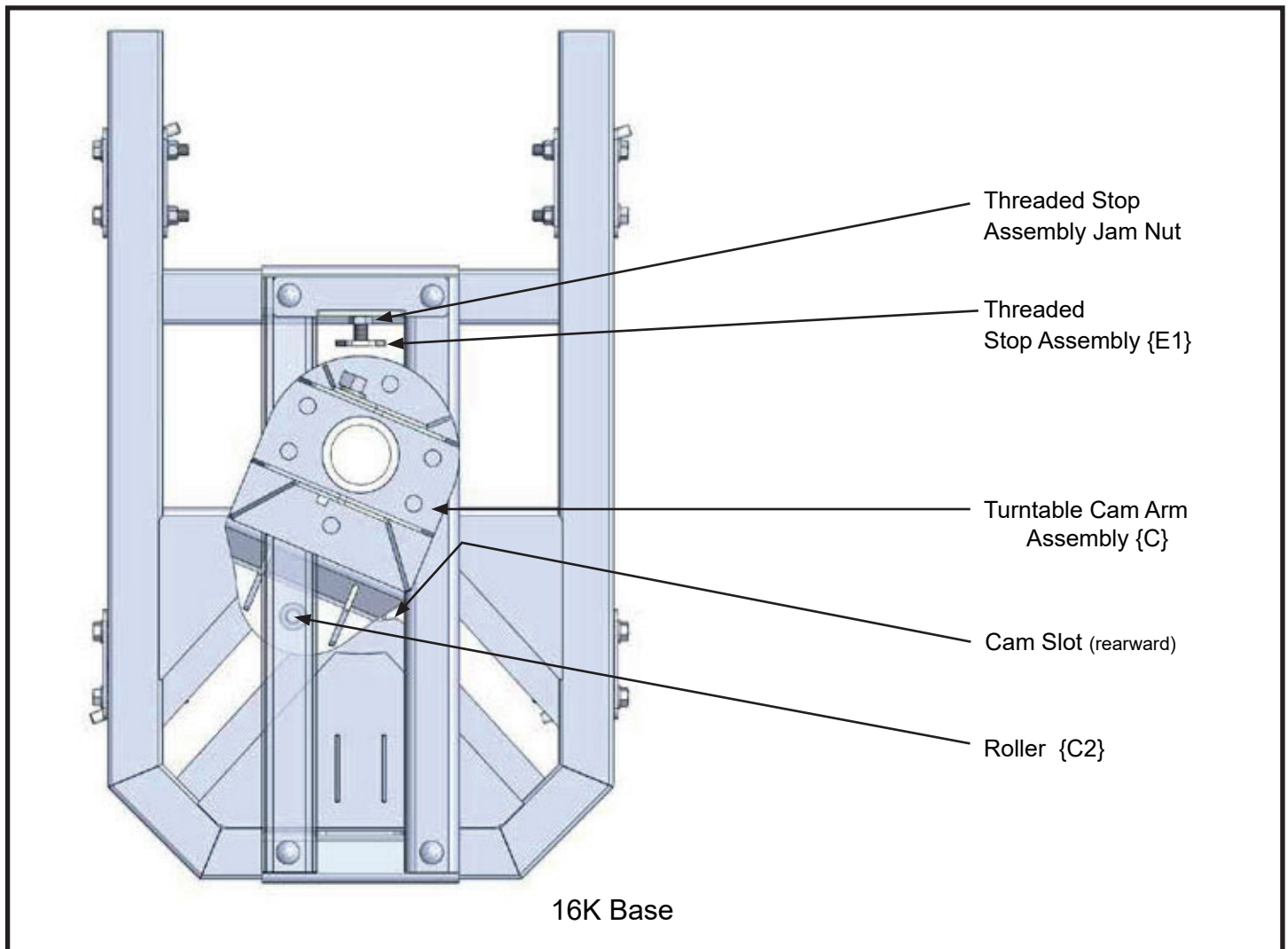

CHALLENGE VS. SOLUTION

CHALLENGE	SOLUTION
Cannot open the Release Handle.	<p>You may have too much rearward pressure against the lock mechanism. Back your truck slightly to relieve pressure and continue the unhitching procedures.</p> <p>If you have positioned the trailer jacks too high, your king pin will be pulled up against the bottom of the jaw, not allowing the jaw to rotate open.</p>
Plate seems dry – Can I use a Teflon pad?	No. The Trailer Plate does not allow for any extra space for a pad. Since the turning action is no longer at the king pin, you will have minimal friction. A light coating of WD-40 or a light oil is sufficient.
Trailer overhang is hitting the truck bed rails when the trailer and truck are at sharp angles.	Most trailer king pin boxes have height adjustment settings available to achieve the necessary clearance between the truck bed rails and the bottom of the trailer. Adjust accordingly.
The latch handle mechanism seems too stiff to operate.	Turn the plate upside-down and spray the locking mechanism with WD-40. Work the handle until it slides freely. If the problem persists, you may need to degrease and re-lube all working parts.
I have attempted to unhitch at an angle greater than 10 degrees, truck to trailer, and the hitch will not release the King Pin.	<p>Back into the King Pin, then using a probe, push the Lock Lever forward until the Lock Catch allows the Lock Jaw Assembly to rotate around the king pin. Retract the trailer jacks and remove the wheel chocks. Maneuver the truck until it is lined up within the 10 degree limit (see pg. 12). Perform unhitching steps 1-6 on page 13.</p> <p>Refer to #7 on page 17 for emergency situations during hooking and unhooking your trailer.</p>
I need to have a professional evaluate my SuperGlide.	Contact PullRite's Customer Service Dept. Your needs will be assessed and resolved by PullRite, or you will be directed to an authorized PullRite Service Center.

FREQUENTLY ASKED QUESTIONS

1. Can I pull other Fifth wheel trailers with my SuperGlide hitch?

Your SuperGlide hitch can only pull trailers equipped with the SuperGlide Capture Plate. If you hook up to a trailer that does not have a Capture Plate installed, there is no control to keep the hitch in the forward towing position and the weight of the trailer will cause the head to turn and slam or “free fall” to the rear of the hitch’s angled cam slot, which may cause damage to the hitch, truck, and the king pin. We do not recommend locking the hitch in any way to keep it in the forward position.

2. Will a standard hitch be able to tow my trailer with the Capture Plate installed?

The Capture Plate will need to be removed from the pin box before a standard fifth wheel hitch can tow your trailer. If the plate is not removed, the king pin will not rotate in the hitch and damage will result to the Capture Plate and conventional hitch. Part # 3336 is a conversion adapter (see pg. i) that will allow a standard fifth wheel hitch to tow your trailer with the Capture Plate installed. The adapter is used in conjunction with your Fifth Wheel Plate, or “head” of the SuperGlide {A}.

3. Is there a cover available for my SuperGlide hitch?

Yes. It is part #2912 and is available from your RV Dealer or by calling Customer Service (not available for #2300 SuperGlide at this time).

4. Can I put a bed liner in my truck after the hitch is installed?

The industry standard base rails can be installed over a spray-in bed liner. All other liners will require an opening to be cut through the liner, to allow the base rails to install against the metal of the bed.

5. How much does my SuperGlide weigh?

#2700 -- 194 lbs.

#2900 -- 224 lbs.

#2300 -- 270 lbs.

6. Can I leave the hitch attached to my trailer and use the trailer jacks to lift the hitch out of the truck?

Yes, you can use the trailer jacks to lift the hitch out of the truck. The hitch should not however be left hanging from the king pin. Once you have the hitch lifted out of the truck you should have a stand available to lower the hitch onto for storage.

FREQUENTLY ASKED QUESTIONS

7. Can I hook up or unhook at a 90 degree angle?

Hooking up can only be accomplished when the truck and trailer are aligned within 10 degrees of each other. See “Hitching” on page 16 for more information on hooking up. Unhooking by pulling the release handle can only be accomplished when the truck and trailer are aligned within 10 degrees of each other. In emergency situations you can pull the clevis pins and clips that attach the Fifth Wheel Plate or “head” assembly to the Rocker Arm, lower your landing gear and raise the trailer up until the Fifth Wheel Plate is free from the Rocker Arm. Pull forward from under the parked trailer. At that point you can pull the Release Handle, remove the head from the king pin and reattach it to your hitch with the clevis pins and clips.

8. Can I use a Teflon disc or lube plate on the king pin plate?

The king pin box and SuperGlide plate or “head” move together and since there is no friction, there is no need for any grease or a lube plate. Use of a Teflon disc or lube plate would cause the king pin to be too short and problems hooking up will occur.

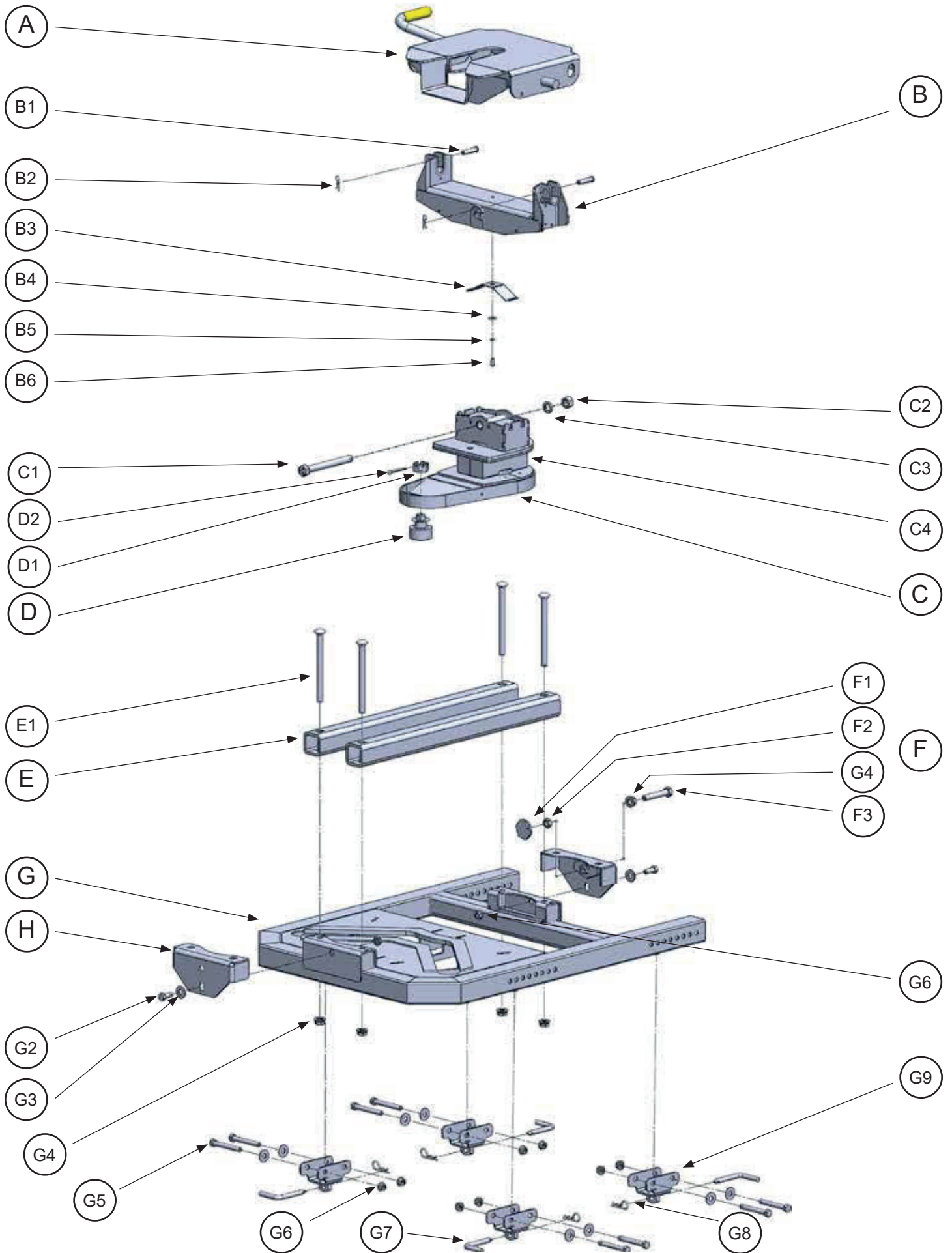

#2300 PARTS LIST

ITEM	DESCRIPTION	PART NO.	QTY.	MATERIAL
A	FIFTH WHEEL PLATE ASSEMBLY	2901	1	
B	ROCKER ARM	2302	1	(See assembly components below in hardware kit)
C	TURNTABLE CAM ARM	2303	1	
C4	CAM ARM SHAFT WEAR PLATES	44120003	2	
D	ROLLER ASSEMBLY	2304	1	
D1	ROLLER SLOTTED NUT	98150121	1	1"-14 SLOTTED NUT,
D2	ROLLER COTTER PIN	98410567	1	1/4" X 2" COTTER PIN
E	TURNTABLE WAY TUBES	23060001	2	
F	CAM ARM STOP ASSEMBLY	2308	1	
F1	THREADED STOP ASSEMBLY	440501	1	
F2	THREADED STOP HEX JAM NUT	98150141	1	5/8"-11 HEX JAM NUT
F3	THREADED STOP BOLT	98010232	1	5/8"-11 X 3.5" HHCS GRD 5
G	HITCH BASE	2307	1	
H	WAY TUBE BRACKET ASSEMBLY	2305	1	
HARDWARE KIT				
B1	ROCKER ARM CLEVIS PIN	98410111	2	#3 COTTER PIN
B2	#3 PIN CLIP	98410127	2	1-2" X 2" CLEVIS PIN
B3	ROCKER ARM SPRING	35100001	1	16 GA SPRING STEEL
B4	ROCKER ARM SPRING FLAT WASHER	98250160	1	5/16" ZINC FLAT WASHER
B5	ROCKER ARM SPRING LOCK WASHER	98200159	1	5/16" ZINC SPLIT LOCK WASHER
B6	ROCKER ARM SPRING BOLT	98010242	1	5/16"-18 X 3/4" HHCS GRD 5
C1	ROCKER ARM PIVOT BOLT	98010147	1	3/4" -10 X 7" GRD 5
C2	PIVOT BOLT HEX NUT	98150131	1	3/4" - 10 ZINC HEX NUT
C3	PIVOT BOLT LOCK WASHER	98200124	1	3/4" ZINC PLATED SPLIT LOCK WASHER
E1	WAY TUBE BOLT	98050130	4	5/8"-11 X 8" CARRIAGE BOLT GRD 5
G2	WAY TUBE HOLDER BOLT	98010177	2	1/2"-13 X 1-1/4" HHCS GRD 5
G3	1/2" FLAT WASHER	98250145	10	1/2" FLAT WASHER
G4	5/8" FLANGE NUT	98150200	5	5/8"-11 SERRATED FLANGE NUT
G5	BASE RAIL FOOT BOLT	98010191	8	1/2"-13 X 4" HHCS GRD 5
G6	1/2" FLANGE NUT	98150201	10	1/2"-13 ZINC SERRATED FLANGE NUT
G7	HITCH PIN	27090001	4	1/2" ROUND
G8	#9 PIN CLIP	98410143	4	#9 COTTER PIN
G9	BASE FOOT ASSEMBLY	291101	4	
BASE RAIL KIT				
<i>BASE RAILS ARE DIFFERENT FOR EACH APPLICATION AND ARE SOLD SEPARATELY.</i>				

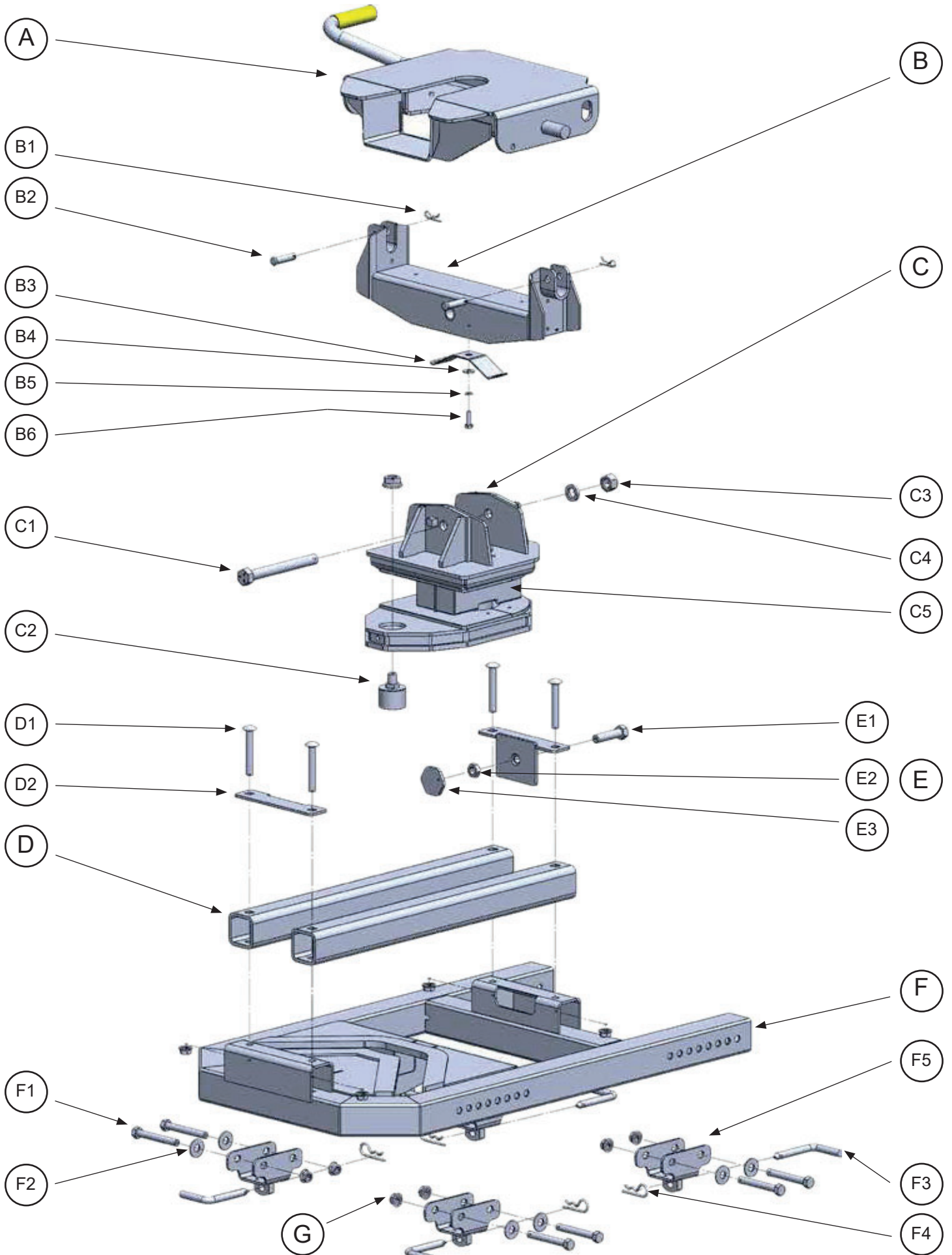

#2900 PARTS LIST

ITEM	DESCRIPTION	PART NO.	QTY.	MATERIAL
A	FIFTH WHEEL PLATE ASSEMBLY	2901	1	
B	ROCKER ARM	3302	1	
C	TURNTABLE CAM ARM	2903	1	
C2	ROLLER	2904	1	ROLLER ASSEMBLY
C5	PLASTIC WEAR PLATE KIT	2910	1	MOLDED PLASTIC WEAR PLATES
D	TURNTABLE WAY TUBES	2906	2	
E	CAM ARM STOP ASSEMBLY	2705	1	
E1	STOP ASSEMBLY BOLT	98010219	1	5/8"-11 X 2-1/2" TAP BOLT GRD 5
E2	STOP ASSEMBLY JAM NUT	98150141	1	5/8"-11 HEX JAM NUT
E3	THREADED STOP ASSEMBLY	4405	1	
F	HITCH BASE	2907	1	
HARDWARE KIT				
B1	#3 PIN CLIP	98410127	2	#3 COTTER PIN
B2	ROCKER ARM CLEVIS PIN	98410111	2	1-2" X 2" CLEVIS PIN
B3	ROCKER ARM SPRING	35100001	1	16 GA SPRING STEEL
B4	ROCKER ARM SPRING FLAT WASHER	98250160	1	5/16" ZINC FLAT WASHER
B5	ROCKER ARM SPRING LOCK WASHER	98200159	1	5/16" ZINC SPLIT LOCK WASHER
B6	ROCKER ARM SPRING BOLT	98010244	1	5/16"-18 X 1" HHCS GRD 5
C1	ROCKER ARM PIVOT BOLT	98010147	1	3/4" -10 X 7" GRD 5
C3	PIVOT BOLT HEX NUT	98150131	1	3/4" - 10 ZINC HEX NUT
C4	PIVOT BOLT LOCK WASHER	98200124	1	3/4" ZINC PLATED SPLIT LOCK WASHER
D1	WAY TUBE BOLT	98050113	4	1/2"-13 X 3-1/2" HHCS GRD. 5 CARRIAGE BOLT
D2	STOP BRACKET BRACE	27050001	1	
F1	BASE BOLT	98010191	8	1/2"-13 X 4" HHCS GRD 5
F2	BASE FLAT WASHER	98250145	8	1/2" ZINC FLAT WASHER
F3	HITCH PIN	27090001	4	1/2" ROUND
F4	#9 PIN CLIP	98410143	4	#9 COTTER PIN
F5	BASE FOOT ASSEMBLY	291101	4	
G	1/2" FLANGE NUT	98150201	12	1/2"-13 ZINC SERRATED FLANGE NUT
BASE RAIL KIT				
<i>BASE RAILS ARE DIFFERENT FOR EACH APPLICATION AND ARE SOLD SEPARATELY.</i>				

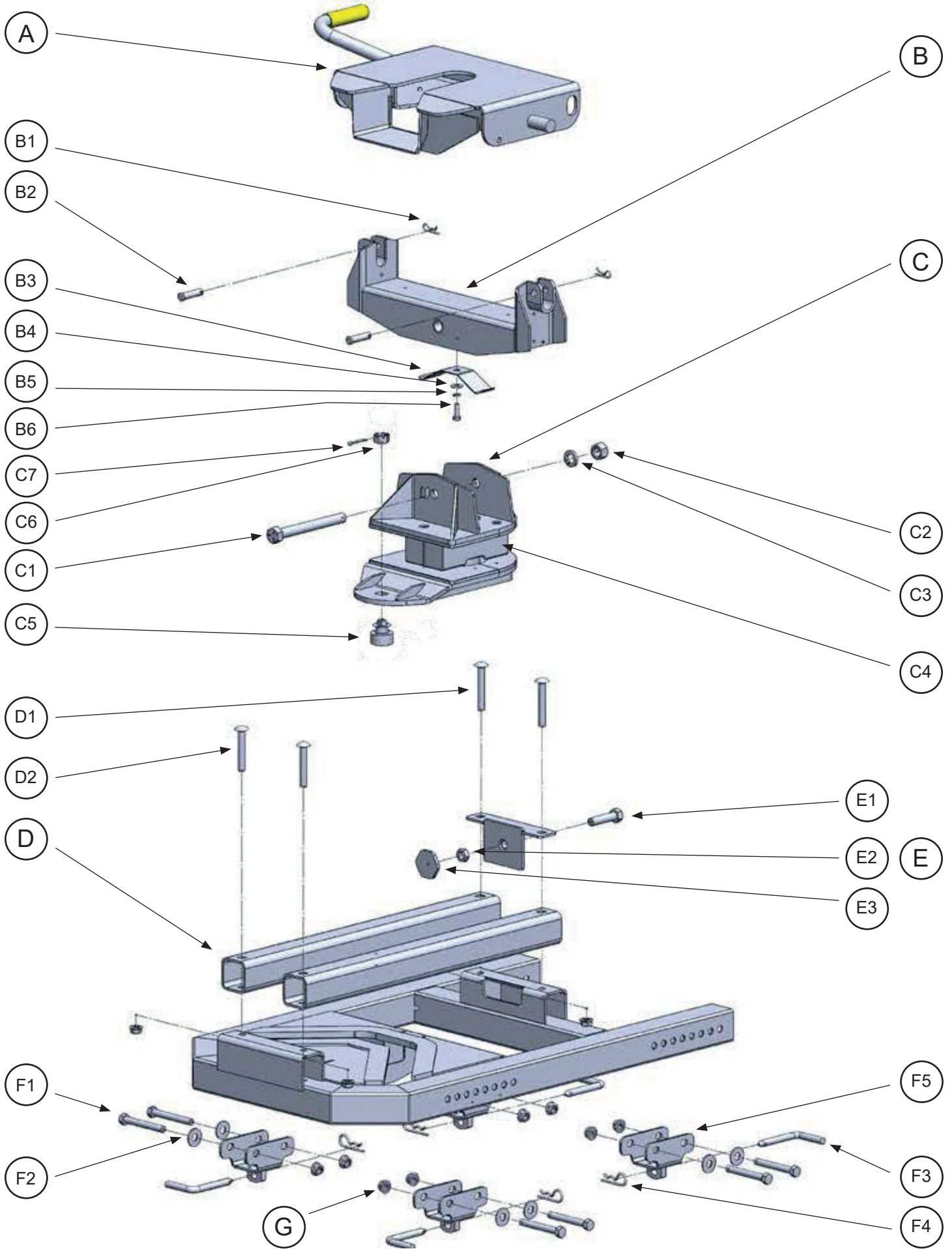

#2700 PARTS LIST

ITEM	DESCRIPTION	PART NO.	QTY.	
A	FIFTH WHEEL PLATE ASSEMBLY	3601	1	
B	ROCKER ARM	3302	1	
C	TURNTABLE CAM ARM	2702	1	
C4	PLASTIC WEAR PLATE KIT	2910	1	MOLDED PLASTIC WEAR PLATES
C5	ROLLER ASSEMBLY	2913	1	
C6	ROLLER SLOTTED NUT	98150121	1	1" - 14 SLOTTED NUT
C7	ROLLER COTTER PIN	98410567	1	1/4" X 2" COTTER PIN ZINC PLATED
D	TURNTABLE WAY TUBES	2706	2	
E	CAM ARM STOP ASSEMBLY	2705	1	
E1	STOP ASSEMBLY BOLT	98010219	1	5/8"-11 X 2-1/2" TAP BOLT GRD 5
E2	STOP ASSEMBLY JAM NUT	98150141	1	5/8"-11 HEX JAM NUT
E3	THREADED STOP ASSEMBLY	4405	1	
F	HITCH BASE	2907	1	
HARDWARE KIT				
B1	#3 PIN CLIP	98410127	2	#3 COTTER PIN
B2	ROCKER ARM CLEVIS PIN	98410111	2	1-2" X 2" CLEVIS PIN
B3	ROCKER ARM SPRING	35100001	1	16 GA SPRING STEEL
B4	ROCKER ARM SPRING FLAT WASHER	98250160	1	5/16" ZINC FLAT WASHER
B5	ROCKER ARM SPRING LOCK WASHER	98200159	1	5/16" ZINC SPLIT LOCK WASHER
B6	ROCKER ARM SPRING BOLT	98010244	1	5/16"-18 X 1" HHCS GRD 5
C1	ROCKER ARM PIVOT BOLT	98010147	1	3/4" -10 X 7" GRD 5
C2	PIVOT BOLT HEX NUT	98150131	1	3/4" - 10 ZINC HEX NUT
C3	PIVOT BOLT LOCK WASHER	98200124	1	3/4" ZINC PLATED SPLIT LOCK WASHER
D1	FRONT WAY TUBE BOLT	98050114	2	1/2"-13 X 3-1/4" HHCS GRD. 5 CARRIAGE BOLT
D2	REAR WAY TUBE BOLT	98050113	2	1/2"-13 X 3-1/2" HHCS GRD. 5 CARRIAGE BOLT
F1	BASE BOLT	98010191	8	1/2"-13 X 4" HHCS GRD 5
F2	BASE FLAT WASHER	98250145	8	1/2" ZINC FLAT WASHER
F3	HITCH PIN	27090001	4	1/2" ROUND
F4	#9 PIN CLIP	98410143	4	#9 COTTER PIN
F5	BASE FOOT ASSEMBLY	291101	4	
G	1/2" FLANGE NUT	98150201	12	1/2"-13 ZINC SERRATED FLANGE NUT
BASE RAIL KIT				
<i>BASE RAILS ARE DIFFERENT FOR EACH APPLICATION AND ARE SOLD SEPARATELY.</i>				



#3336 Conversion Adapter

When your trailer's king pin box has been equipped with any welded Capture Plate or bolted-on Universal Capture Plate, this adapter will allow your trailer to be pulled by a non-SuperGlide hitch **when used in conjunction with the head of your SuperGlide (sold separately #3336)**.

NOTE: Most SuperGlide customers elect to use a custom, removable capture plate, rendering this adapter unnecessary.

1. Remove the SuperGlide Fifth Wheel plate (part# 3601) from the SuperGlide hitch by removing both 1/2" x 2" clevis pins (part #98410111) and pin clips (part #98410127).
2. Slide the SuperGlide Conversion Adapter onto the 5th wheel plate of the "brand X" hitch as seen in Step 1, making certain the Conversion Adapter is securely locked into place.
3. Insert the SuperGlide Fifth Wheel Plate (your SuperGlide hitch head) into the Conversion Adapter "cradles," and secure with the 1/2" x 2" clevis pins and clips.
4. The Conversion Adapter allows the king pin to turn in the conventional style hitch when hooked up to the trailer equipped with a SuperGlide Capture Plate.

NOTE: Hook-up *must* be performed in a straight line.

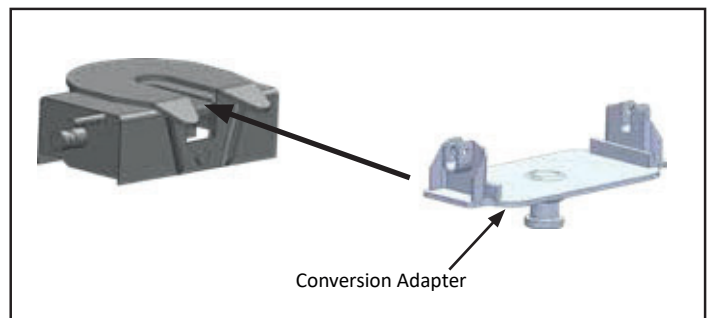

Step 1

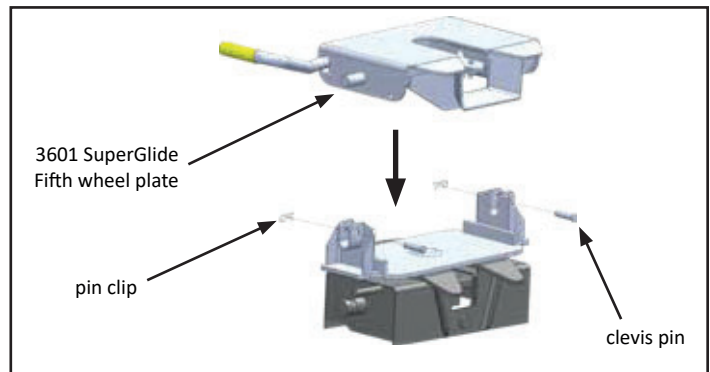

Step 2

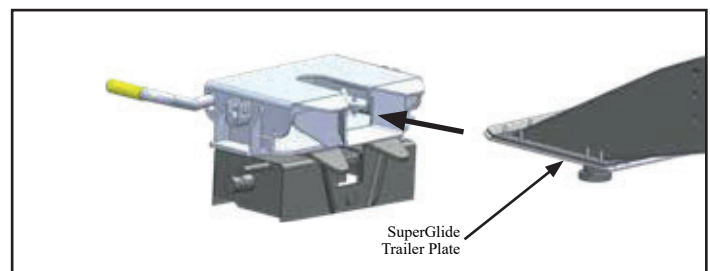

Step 3

