



# Horse Trailer Adapter

## #4424

**WARNING:** You must read the SuperGlide Owner's Manual prior to operating your hitch, paying special attention to proper lubrication (pg. 4) and hitching/unhitching procedures (pg. 8-10). Failure to properly lubricate and follow hook-up procedures to your horse trailer may result in injury to vehicle, person and animal.

**NOTE:** The SG Horse Trailer Adapter is designed for use with a cross pin and will not function properly without it. If your trailer does not have a cross-pin hole, please see the reverse side of this instruction for modification instructions.

1. Check the Parts List quantities below before you begin.
2. Loosen the set screws and remove the cross pin from your existing gooseneck insert.
3. Insert the SG Horse Trailer Adapter so the top of the tube is pointing up and the lip of the King Pin Adapter Plate is facing toward the rear of the truck. The wedge on the underside of the Adapter Plate should be facing away from the truck (see illustration).

**NOTE:** The wedge (B) is bolted on in this application to allow for removal if the trailer needs to be towed by a standard fifth wheel hitch.

4. Adjust the height of the Adapter Plate to match the best height for use with your SuperGlide hitch and horse trailer. Refer to pages 8 & 9 of your SuperGlide Owners Manual for proper height adjustment.
5. Once the proper height is achieved, insert the cross pin and retighten the set screws.

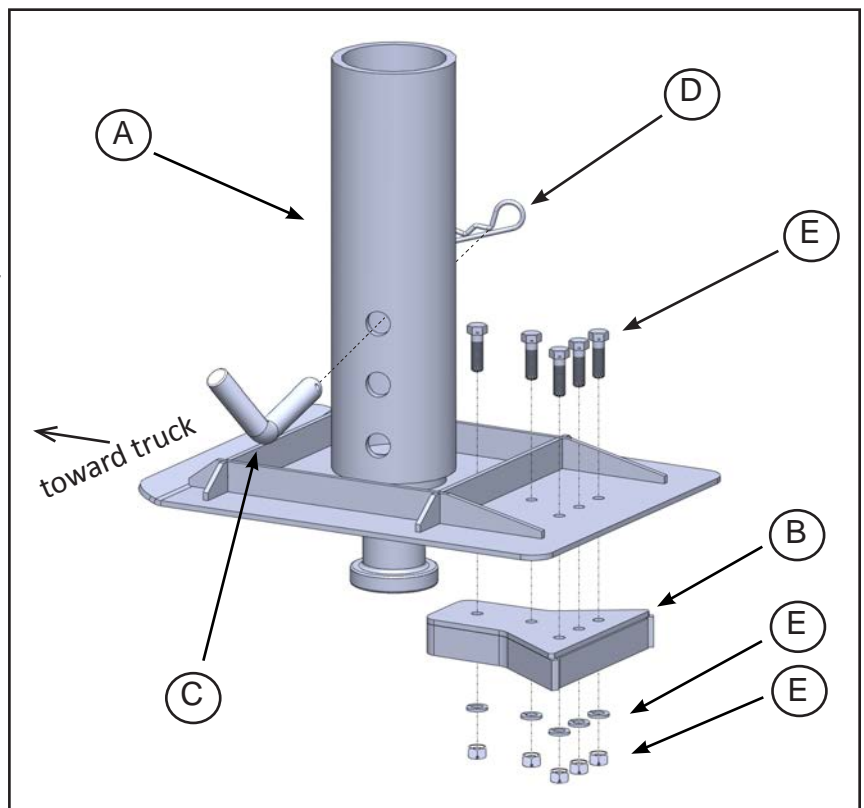

### PARTS LIST

Item	Description	Part No.	Qty.	Material
A	KING PIN ASSEMBLY	442401	1	
B	CAPTURE WEDGE ASSEMBLY	442405	1	
C	#4424 CROSS PIN	44240701	1	3/4" RD.
D	PIN CLIP	98410143	1	#9 PIN CLIP
E	#4424 HARDWARE KIT	442406	1	KIT INCLUDES ABOVE HARDWARE

# Cross-Pin Modification Instructions

1. Insert the SuperGlide Horse Trailer Adapter into the trailer's drop tube, leaving the last two holes visible (see Figure 1) and tighten the existing set screws to hold the adapter in place.
2. Verify that the Adapter is set square to the trailer by measuring on the diagonal from identically opposite points as illustrated in Figure 2 below.
3. Once the adapter is square to the trailer, starting on the driver side, draw a vertical center line through the holes in the adapter, extending the line at least 2" up the drop tube of your trailer. This will help you in finding the correct location to drill for the cross pin. See Figure 1.
4. Using the centerline as a guide, measure 1-1/2" up from bottom of drop tube, mark, and center punch where your drawn lines intersect.
5. Repeat Steps 3 & 4 for the passenger side of the trailer. Remove the SG Horse Trailer Adapter and set aside.
6. Drill holes independently from each side, starting with a small 1/8" drill bit, and working progressively larger to 3/4".
7. Deburr the drilled holes, especially on the inside of the drop tube and reinstall the Adapter as before, and insert the 3/4" cross pin through all four holes so that it comes out cleanly on the other side. Once in place, install the pin clip.
8. Tighten set screws.
9. If the cross pin does not insert cleanly through all four holes, use a 3/4" diameter drill bit at least 5" long, and "line drill" through all four holes until the cross pin can be installed cleanly.

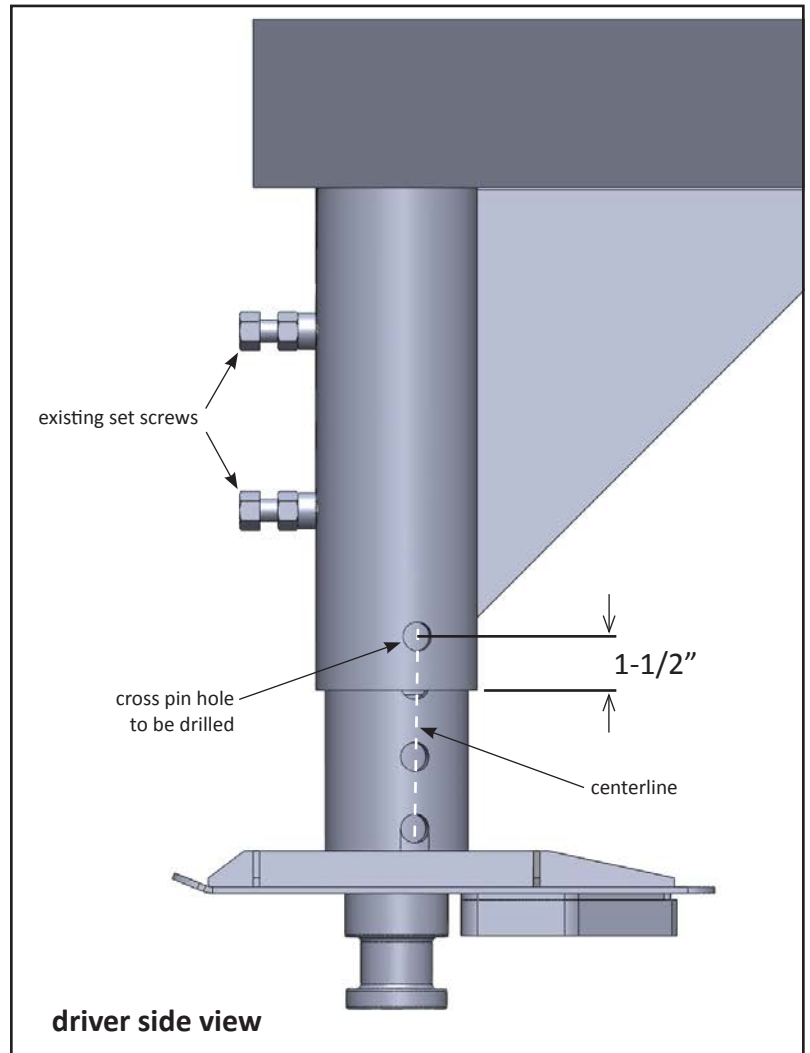

Figure 1

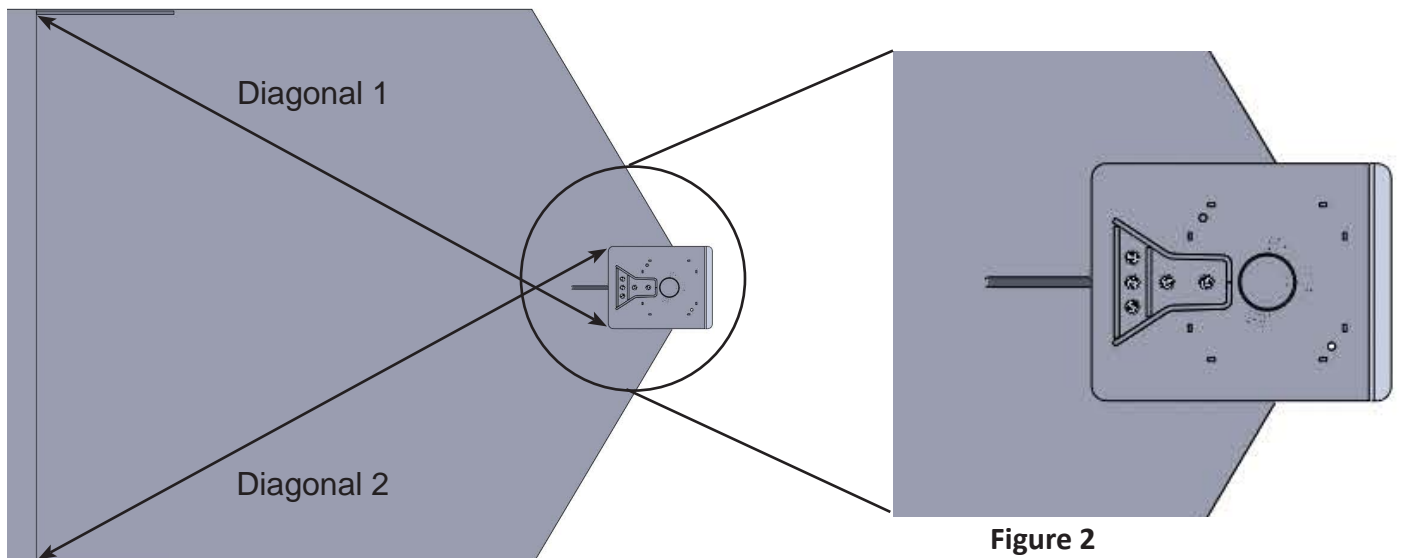

Figure 2