

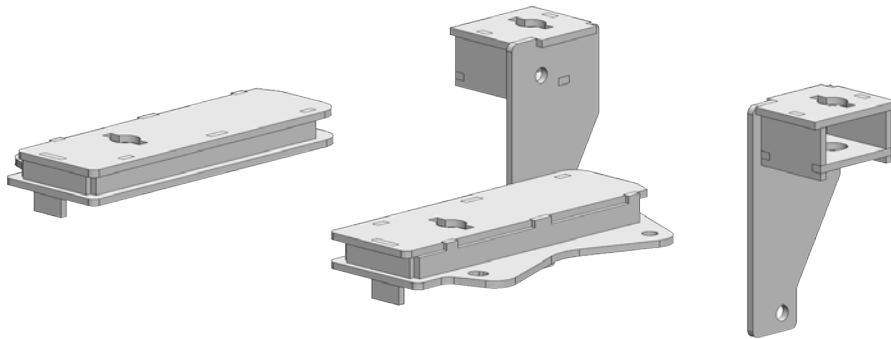

DODGE

12K Custom SuperRail [Mounting Kit](#)

#3122



Gross Trailer Weight (Maximum)..... 12,000 lbs.
Vertical Load Weight (Max. Pin Weight) 3,000 lbs.

Installation Instructions

SPECIFICATIONS

- Fits 2009-2016 Dodge 1500 ton w/ 5' 7" or 6' 6" bed
 - Hitch located center of the axle
 - Added limitations on trailers over 96" wide

IMPORTANT

DO NOT OPERATE HITCH UNTIL YOU READ THIS SECTION!

1. The SuperGlide hitch was designed to allow the Turntable Cam Arm Assembly to “glide” along two metal tubes, called the Way Tubes. Since its release in 1998, we have made several advancements in the design, strength, and durability of these components. The Lubrication section of your Owners Manual spans several product releases and design changes. It is *imperative* that you read each section and determine which SuperGlide hitch you purchased, and how to care for it. There have been three major lubrication changes to the SuperGlide hitch:

- Prior to April 2008, Way Tubes were assembled with either a conventional, quality grade grease or none at all
- In April 2008, we started coating the Way Tubes with a graphite-based spray lubricant called SlipPlate™
- November 2009 brings a new innovation from PullRite Towing Systems with the use of plastics. The Turntable Cam Arm Assembly is now equipped with Plastic Wear Plates; see Owners Manual for details (not available for #3600 models)

Depending on when your hitch was manufactured, the Way Tubes of your new SuperGlide hitch will meet one of the above criteria. Each application listed requires some level of maintenance, so it is important that you read the following instructions carefully for the correct lubrication instructions.

Failure to properly lubricate the Way Tubes, as directed in this section, will eventually cause galling between the metals of the Way Tubes and Cam Arm Assembly, which will result in hitch failure. Destruction of various hitch parts is also likely, as well as truck and/or trailer damage, and will not be covered under the Manufacturer’s Warranty.

2. **THE TRAILER’S KING PIN BOX MUST BE EQUIPPED WITH A CAPTURE PLATE (UNIVERSAL OR QUICK CONNECT) TO ALLOW THE HITCH TO FUNCTION (MUST BE PURCHASED SEPARATELY). NOTE: IF YOU HAVE PURCHASED A QUICK CONNECT CAPTURE PLATE AND DID NOT RECEIVE INSTRUCTIONS, THEY ARE AVAILABLE ONLINE.**
3. Failure to modify the length of the brake away cable that activates the emergency braking of your trailer, may cause the cable to catch on protruding parts of the hitch. Resulting damage will not be covered by the manufacturers warranty.
4. There should be a minimum of 6” between the truck bed rails and the under side of the trailer for side tilt clearance. It is the customers responsibility to adjust the trailer king pin box for the appropriate amount of clearance.
NOTE: Some truck models are being manufactured with higher bed sides, making it necessary to adjust the height of your trailer’s king pin box. If you don’t have enough height adjustment available, PullRite produces a 3” Lift Kit that attaches to the rails of your #3100 (ask for part #3108) or #4100, #3300 and #4400 (ask for part #4408; *rated only for 18K when used with model #4400*) SuperGlide models.
5. Some truck beds have contoured bed sides, making the inside bed measurement narrower. Make certain the trailer’s king pin box does not contact the inside edge of the bed.
6. Trucks with bed liners may need a tall Mounting Post. See “NOTE” under “Drilling the Bed” for further details.
7. It is the installers and customers responsibility to ensure there is proper clearance between the truck and trailer. There should be a minimum of 2” of clearance as the trailer passes the cab.
8. Read these instructions completely and follow them accurately.
9. The SuperGlide was designed for short bed pickup trucks. The hitch may function in a longer bed truck, but no mounting brackets exist to make the transfer. Some #4100 and #4400 mounting kits may transfer with modification.

#3100 SuperGlide Applications

The #3100 SuperGlide was designed for specific short bed pickup trucks. The hitch may function in a longer bed truck, but no mounting brackets exist to easily make the transfer.

MOUNTING HARDWARE PARTS IDENTIFICATION

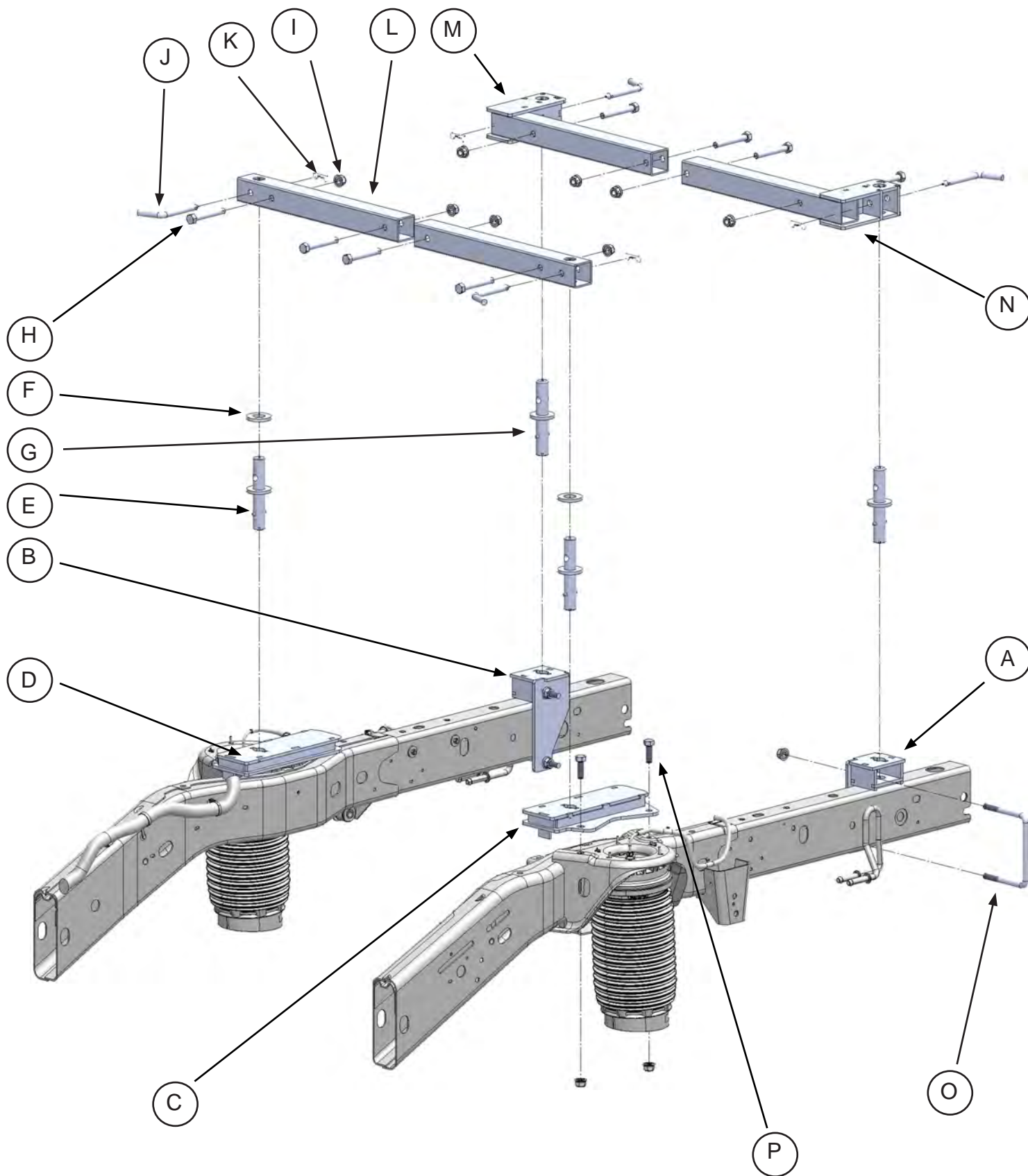

PARTS LIST

#3122 DODGE BRACKET KIT

Item	Description	Part No.	Qty.	Material
A	REAR DRIVER SIDE BRACKET	312204	1	
B	REAR PASSENGER SIDE BRACKET	312203	1	
C	FRONT DRIVERS SIDE POST HOLDER	312001	1	
D	FRONT PASSENGER SIDE POST HOLDER	312002	1	
L	FRONT BASE RAILS	31200601	2	BASE RAILS (18-7/16" LONG)
M	REAR PASSENGER SIDE BASE RAIL	312206	1	
N	REAR DRIVER SIDE BASE RAIL	312205	1	
	HARDWARE KIT	312207	1	(SEE KIT CONTENTS BELOW)

#312207 — MOUNTING BRACKET HARDWARE KIT

Item	Description	Part No.	Qty.	Material
E	FRONT MOUNTING POSTS	311507	2	* TITAN MOUNTING POST ASSEMBLY
F	MOUNTING POST FLANGE	33070102	2	
G	REAR MOUNTING POSTS	330701	2	3300 MOUNTING POST ASSEMBLY
H	BASE RAIL BOLTS	98010187	8	1/2"-13 x 3-1/2" HHCS GRD 5
I	1/2" FLANGE NUT	98150201	16	1/2" - 13 SERRATED FLANGE NUT
J	BASE RAIL PINS	08060001	4	1/2" RD.
K	PIN CLIP	98410127	4	#3 PIN CLIP
O	U-BOLT	98050181	2	1/2" X 5-7/8" X 4-7/8" U-BOLT
P	FRONT MOUNTING POST HOLDER BOLTS	98010167	4	1/2" - 13 x 1-1/2" HHCS GRD 5

LAYOUT TEMPLATE

Description	Part No.	Qty. Used	Material
LAYOUT BED TEMPLATE	31220000	1	ITEM SOLD SEPARATELY

TRUCK PREPARATION

1. Check part quantities using the Parts List.
2. Block vehicle wheels. Some vehicles may require you to raise the rear of the truck in order to make it easier to drill for installing the mounting brackets on the truck frame.
3. You may wish to remove the wheels to give yourself greater working room.
4. Carefully remove the plastic inner wheel well guards on both sides of the vehicle.
5. If equipped, unclip the air supply line from the frame near the air bag area and from the top of the air bag mounting bracket on both sides of the vehicle. Zip tie or tape the wiring harness out of the way during the installation process so no wires are severed.
6. There are two 3/8" holes located on the top of the coil spring or air bag mounting bracket (right). These holes need to be drilled out to 1/2" using a step drill. There is room to fit the drill up from the bottom. Repeat this step for both sides of the vehicle.
7. If you have purchased a template, proceed to the "Template Method" below; otherwise, begin with the "Layout Method."

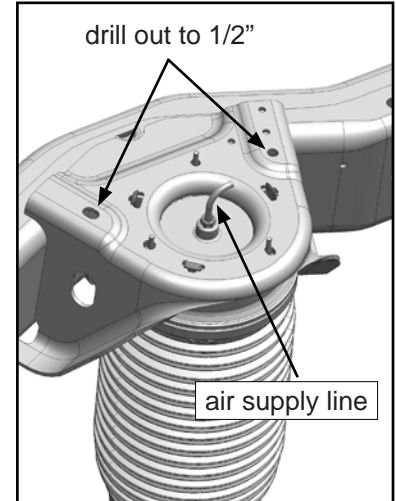

MARKING THE TRUCK BED FOR DRILLING

LAYOUT METHOD

If you purchased an installation template, please proceed to "TEMPLATE METHOD". *Templates are sold separately.*

1. Referencing "Truck Bed Dimension Table" below, measure and mark from the back of the bed forward, the values for "A" and "B". Do this at any point on both sides of the bed.
2. Draw a line across the bed from mark to mark.
3. Find the centerline of the bed.
4. Draw a line down the middle of the bed from front-to-rear.
5. Center the measurement of "C" across the centerline at the front-most line you made in step 2 and mark the measurement on each side (parallel to the centerline).
6. Center the measurement of "D" for the rear most line made in step 2, and again mark the measurement on each side (parallel to the centerline). This will locate the 4 drill holes.

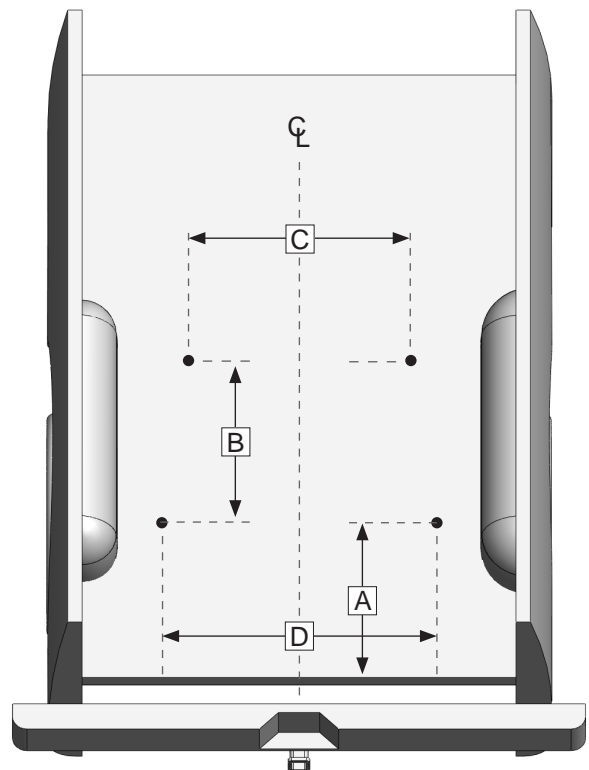

TRUCK BED DIMENSION TABLE					
LAYOUT METHOD				TEMPLATE METHOD	
"A"	"B"	"C"	"D"	"X"	Template part#
9-3/4"	34-1/8"	35-7/8"	38-7/8"	8-3/4"	31220000

TEMPLATE METHOD

1. Lay the template in the truck bed, centering it from side-to-side, and parallel to the end of the truck bed using the dimension "X" listed in "Truck Bed Dimension Table."
2. Mark the 4 *outside* holes, while making sure the template does not move.

INSTALLATION TIP: *The template has a tendency to move when placed on the slick paint of new truck beds, and it may be helpful to place a small piece of NON-SKID matting, such as "SCOOT-GARD"™ or simply use duct tape on each corner to help keep the template from moving.*

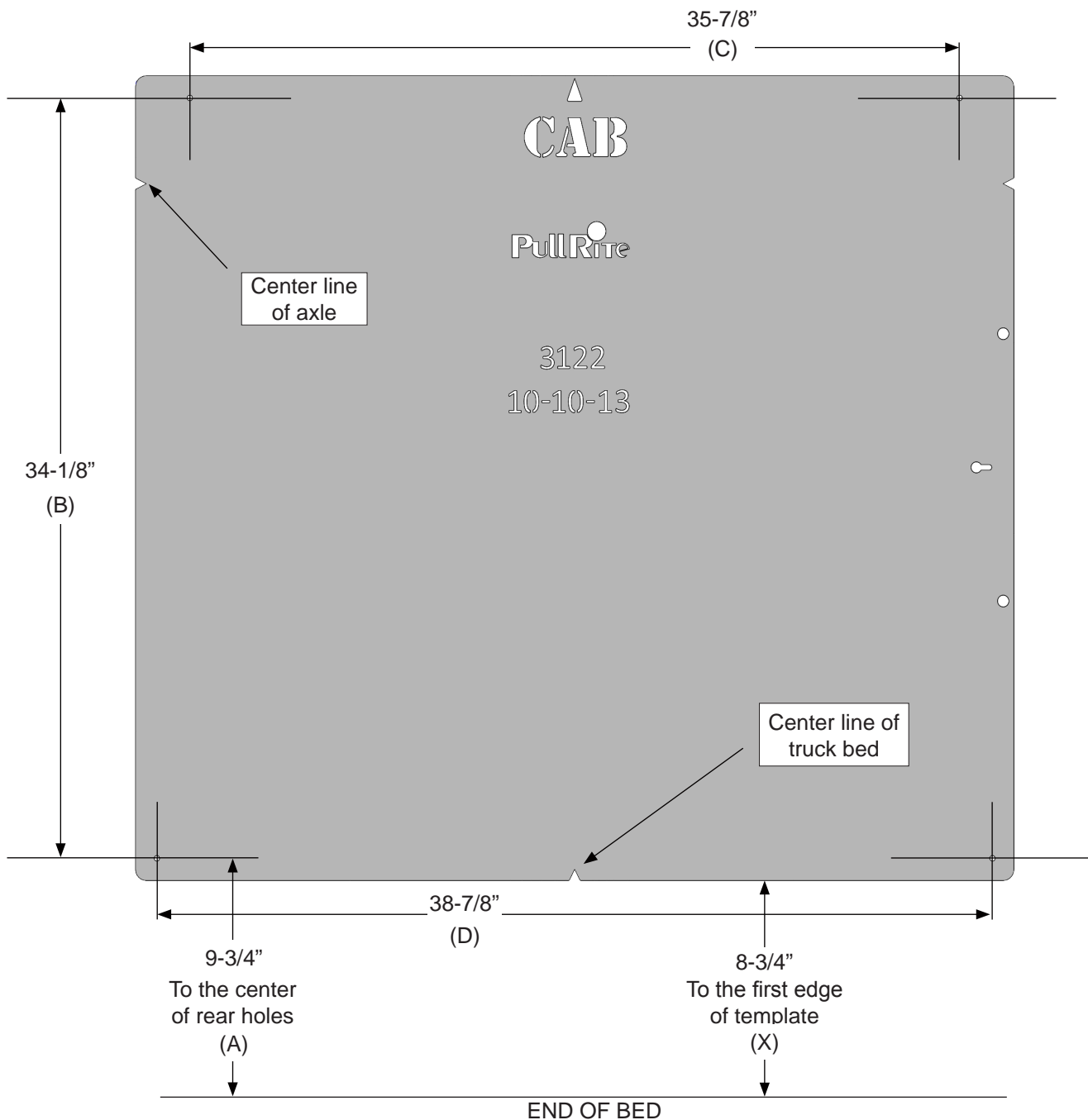

INSTALLATION

PART 1: BRACKET PLACEMENT & BED HOLE LOCATIONS

Since most truck beds are not installed square to the frame or are the same distance from the back of the cab, the installer will need to make sure the bed holes line up properly with the center of each mounting post hole.

The basic steps in this section are as follows:

- Layout the bed holes
- Drill the first pilot hole in the bed
- Check centering using the tape method
- Adjust the bed hole layout if necessary
- Drill the second pilot hole and check centering to ensure bed hole locations are square to the frame; adjust as needed
- Drill remaining pilot holes in the bed; check centering
- Drill truck frame, if necessary

Detailed Installation Instructions

1. Use transparent tape to cover the mounting post hole on the top of each mounting bracket (when the pilot hole is drilled through the bed, the tape will be pierced by the small drill; it should be positioned in the center of the 1" mounting post hole).
2. Install the front driver side mounting bracket {C} to the frame by sliding it between the top of the coil spring or air bag mounting bracket and the frame, aligning the holes in the mounting bracket to the holes you drilled out in "Truck Preparation." Make sure the mounting post hole is positioned toward the front of the truck as seen in the picture below.
3. Fasten the mounting bracket flush to the top of the coil spring or air bag mounting bracket (some mounting brackets may have a slight warp due to the metal characteristics during the welding process) by inserting the 1/2" bolts {P} provided.

WARNING: Prior to drilling any holes, be sure to check the inside of the frame to guard against drilling into the fuel tank, wiring, brake and air lines, fuel module, or any other component.

front driver side view

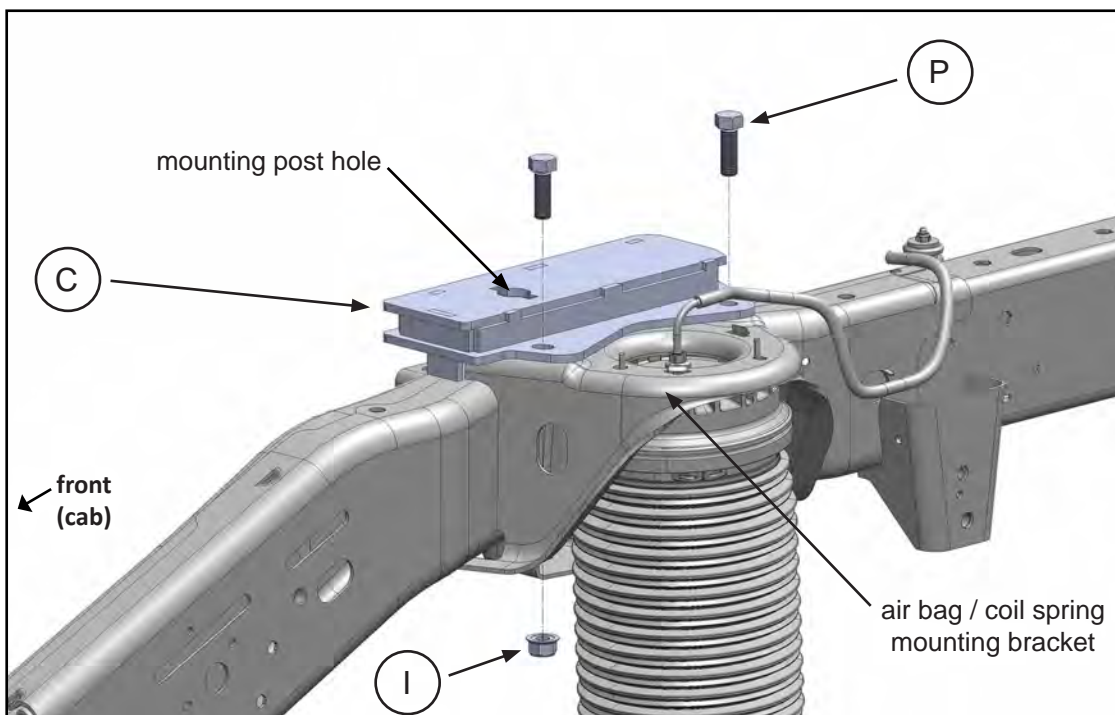

INSTALLATION

4. Drill the first 1/16" pilot hole through the truck bed over the front hole on the driver side where you made the mark during the "Marking Bed for Drilling." The bit should come down through the 1" mounting post hole, piercing the transparent tape, aiding the centering of the bracket front-to-rear and side-to-side.
5. If the pilot hole is off center to the 1" mounting post hole, remember to adjust all the pilot hole locations accordingly.

NOTE: Some truck beds are not installed square on their frame by the manufacturer. To ensure your pilot holes are aligned properly, it is important that you use the measurements provided only as a starting point and make adjustments as needed. Once you have the front driver side pilot hole centered, you will use this hole as a point of reference for all remaining pilot hole adjustments. If you are using the Template Method, simply use the properly drilled hole as a pivot point to square the remaining holes to the frame. If you are using the Layout Method, you may accomplish the same thing by using a framing square and straight edge.

6. Repeat Steps 2-5 for the Front Passenger Side Mounting Bracket {D}, checking carefully for proper centering.
7. The Rear Driver Side Mounting Brackets are positioned rearward of the crossmember as illustrated below. Align the rear driver side mounting bracket {A} to the inside of the frame.
8. Repeat Steps 3-5 for both rear brackets {A} and {B}, making sure both brackets sit flush on top of the frame by using a "C" clamp to secure them.

NOTE: Final bracket placement is dependent on the fixed position of the front brackets. The rear brackets can be moved forward and back to achieve the 34-1/8", "B" measurement indicated on Pages 6 & 7.

WARNING: Before proceeding to "Part 2, "Drilling the Bed...", you must verify that each pilot hole is centered over the 1" mounting post hole on each bracket before the 2" mounting post holes are drilled through the bed.

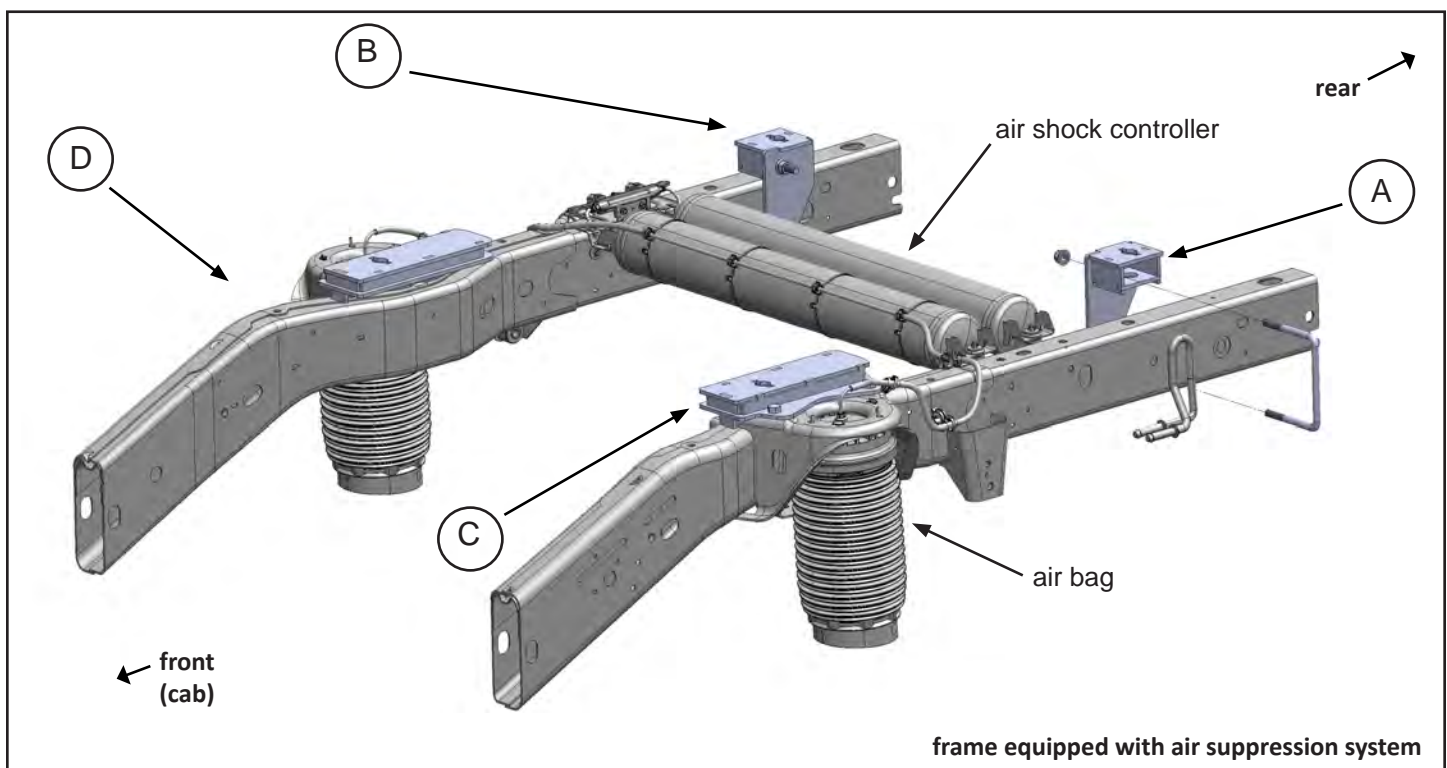

INSTALLATION

PART 2: DRILLING THE BED & BRACKET INSTALLATION

1. Remove the mounting brackets. Using a 2" hole saw centered over the 1/16" pilot hole, cut the bed for the mounting posts.
2. De-bur inside the holes and use a paint stick to touch up the edges.

Front Bracket Installation

1. Install the Front Mounting Brackets {C} & {D}, to the frame by sliding the bracket between the top of the coil spring or air bag mounting bracket and the truck bed, aligning the holes for proper mounting and being aware of air lines that you had moved out of the way during "Truck Preparation."
2. Fasten the mounting brackets securely to the frame using the hardware provided. Finger tighten only.

Rear Bracket Installation

1. The Rear Mounting Brackets use U-bolts {O} to secure them bracket to the frame. Install the U-bolt on the outside of both driver and passenger side of the truck frame, lining them up to the holes on the Mounting Bracket as a guide. Make certain the bracket is sitting flush on top of the frame and against the frame's side wall.

NOTE: The rear brackets have a Left and Right orientation. Make sure you get them installed on the correct side of the vehicle. Refer to previous illustrations for proper parts identification and orientation.

2. Fasten each U-bolt to the Mounting Brackets using the hardware provided. Finger tighten only.

3. Install the mounting posts through the bed into the mounting bracket post holders. Rotate the posts a quarter turn (right). Four posts are required for installation.

NOTE: Vehicles using plastic bed liners may require taller mounting posts to seat properly into the post holders. If taller posts are needed, exchange the front mounting posts {E} with part #330705 (marked with an "X" on the top of the post), and the rear mounting posts {G} with part #311512 (marked with a "TT" on the top of the post).

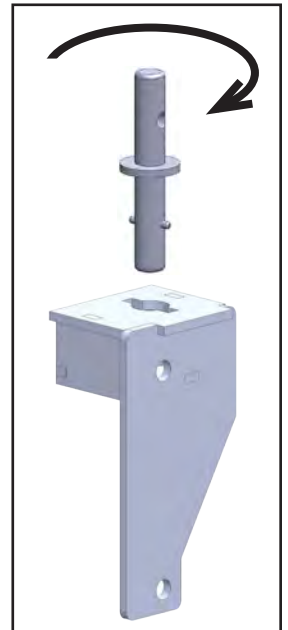

INSTALLATION

PART 3: HITCH ALIGNMENT

1. Remove the SuperGlide hitch from the shipping carton.
2. Install base rails onto the base of the hitch (offset base rails at the rear, standard rails at the front...obround hole facing downward on all rails), using the supplied bolts.
3. Loosely tighten the base rail bolts to the base allowing lateral movement as you place the rail assembly over the mounting posts.
4. Place the hitch and install the hitch pins and clips to secure the hitch assembly to the Mounting Posts.

PART 4: FINAL INSTALLATION PROCEDURES

1. Tighten mounting bracket bolts first, then base rail bolts, according to the Torque Table below.

NOTE: When tightening the rear mounting brackets, torque the bolts only until the backer plates begin to “bend.”

2. Remove the hitch and base rail assembly to verify that the mounting posts can be inserted and turned freely without binding. You may need to loosen the bolts on the mounting brackets below if binding occurs. Adjust as needed and retighten the bolts.
3. Reinstall the mounting posts, installing the mounting post flanges on the *front posts only*, base rails, and the SuperGlide hitch, until the assembly can be removed freely without binding.

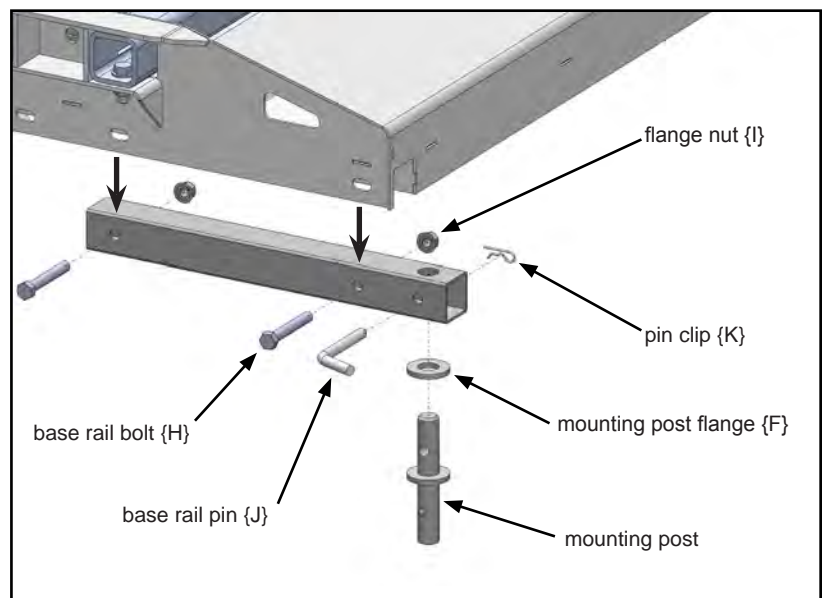

TORQUE TABLE

3/8" bolt	— 31 ft. lbs.
1/2" bolt	— 75 ft. lbs.
5/8" bolt	— 151 ft. lbs.
3/4" bolt	— 266 ft. lbs.