

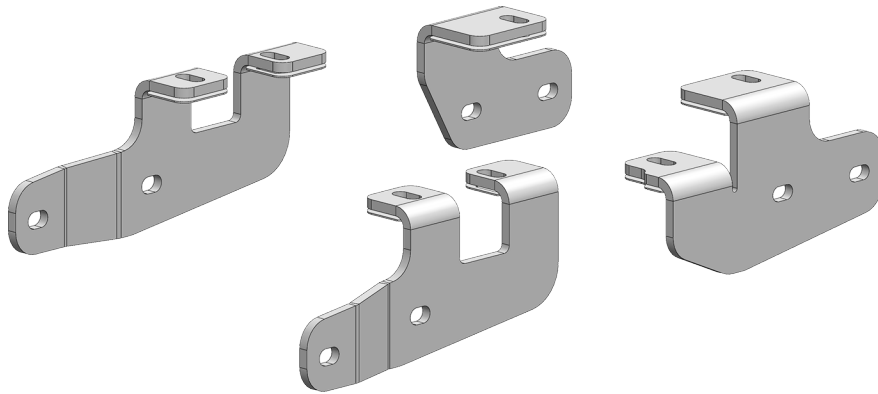

# DODGE

20K Industry Standard Rail Custom [Mounting Kit](#)

## #2746



Gross Trailer Weight (Maximum).....20,000 lbs.  
Vertical Load Weight (Max. Pin Weight) .....5,000 lbs.

### SYSTEM TOW CAPACITY

Please note, in order to determine the **total tow capacity** of a system, you must consider the weight ratings of each component in that system. This includes, but may not be limited to, the capacity/rating of the **tow vehicle**, the **fifth wheel hitch**, and the hitch's **mounting system**. Actual tow capacity of the system will be equal to the lowest rated component.

---

# Installation Instructions

---

## SPECIFICATIONS

- Fits 2014-2016 Dodge 2500
- Hitch is located center of axle
- Custom Mounting Bracket Kit (*Bracket & Hardware*) #2747

## PLATE ASSEMBLY

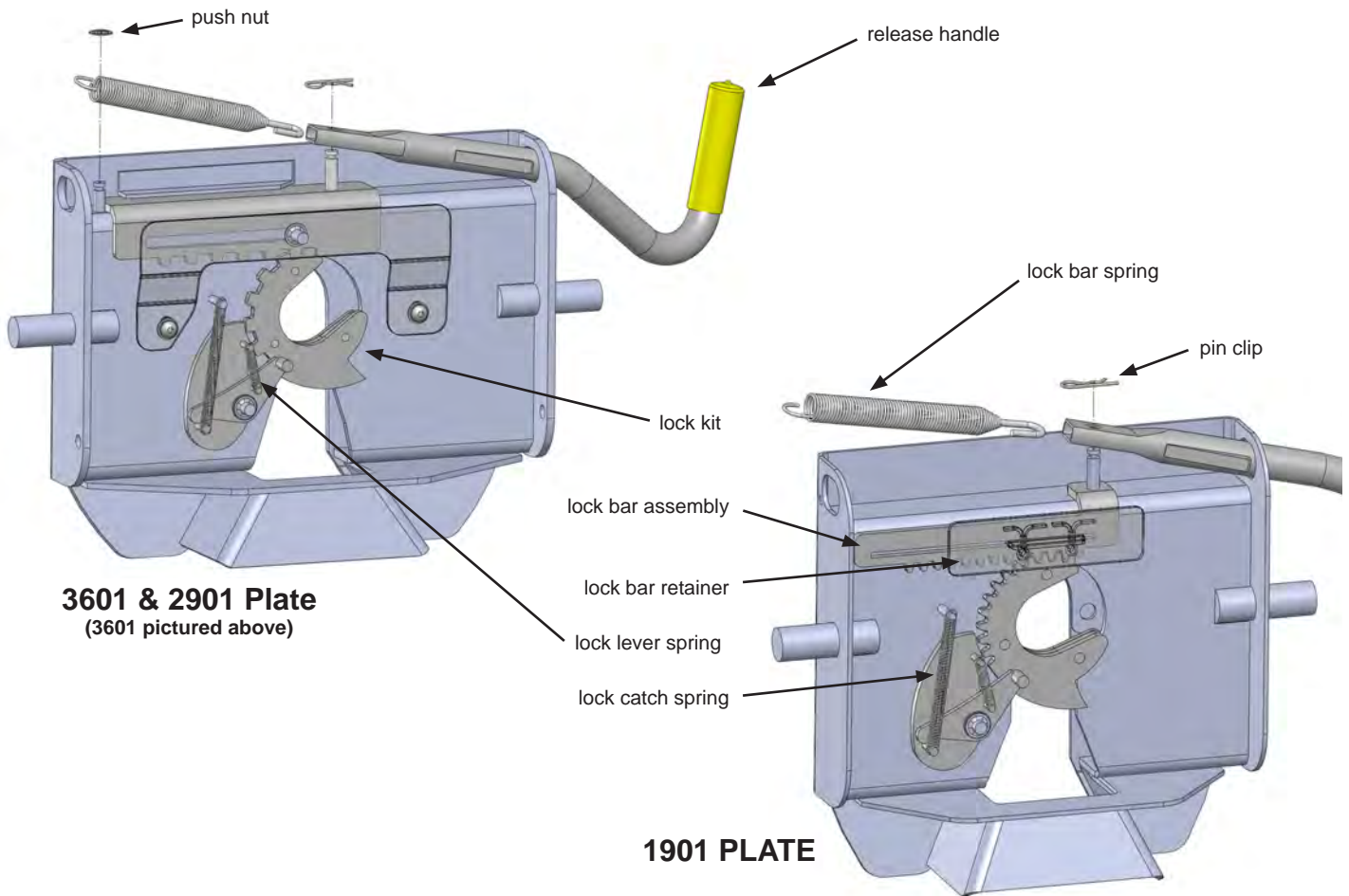

1. Remove the Fifth Wheel Plate from the Rocker Arm and place it upside down on a smooth, clean surface.
2. Insert the Release Handle into the obround hole of the plate as seen above.
3. The Lock Bar Spring must be placed inside the handle prior to placing the handle down over the pin of the Lock Bar Assembly, "catching" the hook inside the handle around the pin.
4. Push the handle and spring assembly down past the groove in the pin of the Lock Bar Assembly, and place one of the Pin Clips in the groove of the pin to fasten.
5. Grip the body of the spring and stretch it far enough over the opposite pin (welded to the plate) and push it down past the groove.
6. Install the Push Nut to secure the Lock Bar Spring onto the welded pin.

**NOTE:** The 1901 plate for the #1900 Super 5<sup>th</sup> does not use a push nut to attach the end of the spring, but rather a slot in the side of the fifth wheel plate located above the obround hole. See illustration to the right.

As a PullRite fifth wheel hitch owner, it is important for you to study and manually operate the Fifth Wheel Plate and Release Handle to better understand the locking action. A better working knowledge of the plate will help prevent accidental dropping of your trailer due to incorrect hitching.

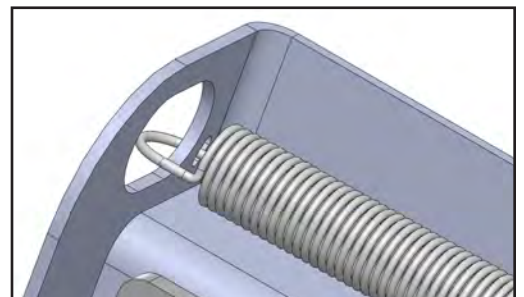

Also, it is imperative that you study and adhere to the Maintenance procedures provided in the Owners Manual.

# MOUNTING KIT EXPLODED VIEW

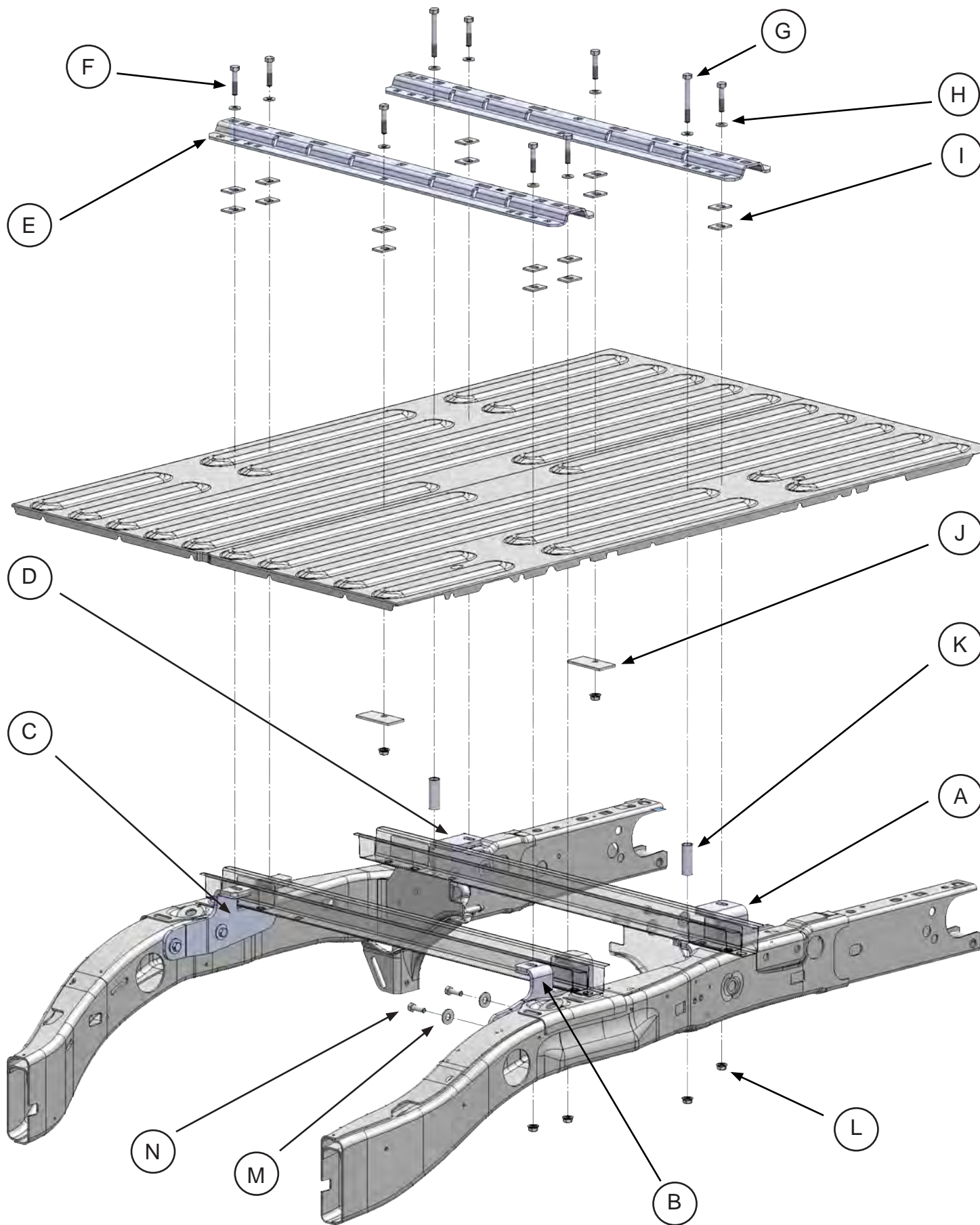

# MOUNTING KIT PARTS LIST

## #2746 DODGE CUSTOM ISR BRACKET KIT

description	part no.	qty	material
MOUNTING BRACKET KIT	2747	1	(See kit contents listed below)
BASE RAIL KIT	2719	1	(See kit contents listed below)

### #2747 — MOUNTING BRACKET KIT

item	description	part no.	qty.	material
A	REAR DRIVER SIDE MOUNTING BRACKET	274703	1	
B	FRONT DRIVER SIDE MOUNTING BRACKET	274701	1	
C	FRONT PASSENGER SIDE MOUNTING BRACKET	274702	1	
D	REAR PASSENGER SIDE MOUNTING BRACKET	274704	1	
	MOUNTING BRACKET HARDWARE KIT	274705	1	(See kit contents listed below)

### #274705 — MOUNTING BRACKET HARDWARE KIT

item	description	part no.	qty.	material
F	2-1/4" BASE RAIL BOLT	98010178	8	1/2"-13 X 2-1/4" HHCS GRD 5
G	4" BASE RAIL BOLT	98010191	2	1/2"-13 X 4" HHCS GRD 5
H	BASE RAIL WASHER	98250147	10	1/2" FLAT WASHER
I	FLAT BASE RAIL SPACER	27410501	16	
J	OFFSET HOLE BACKUP SHIM	05070303	2	
K	BED CHANNEL SPACER TUBE	27290103	2	
L	1/2" FLANGE NUT	98150201	10	1/2"-13 SERRATED FLANGE NUT
M	1/2" FLAT WASHER	98250145	9	1/2" FLAT WASHER
N	1-1/2" TAP BOLT	98010111	8	M12-1-1/2" X 45MM CLASS 10.9 TAP BOLT

### #2719 — BASE RAIL KIT

item	description	part no.	qty.	material
E	BASE RAILS	27190001	2	

### LAYOUT TEMPLATE

description	part no.	qty.	material
LAYOUT BED TEMPLATE	27200000	1	ITEM SOLD SEPARATELY

# TRUCK PREPARATION

1. Block vehicle wheels. Some vehicles may require you to raise the rear of the truck to install the mounting brackets on the truck frame.
2. You may wish to remove the wheels to give yourself greater working room.
3. Remove the spare tire. This will allow easy access to the inside of the truck frame. The fender support at the front of the wheel well may also need to be removed in order to drill front hole locations.
4. Remove the exhaust heat shield.
5. Temporarily detach the wiring and vacuum lines from between the frame and the fuel tank for the Driver Side Front Mounting Bracket installation.

## MARKING THE TRUCK BED FOR DRILLING

### LAYOUT METHOD

If you purchased an installation template, please proceed to "TEMPLATE METHOD". *Templates are sold separately.*

1. Referencing "Truck Bed Dimension Table" below, measure and mark from the back of the bed forward, the values for "A." Do this at any point on both sides of the bed and draw a line across the bed from mark to mark.
2. Find the centerline of the bed.
3. Draw a line down the middle of the bed from front-to-rear.
4. Starting at "A," measure from the end of the bed back to the first bolt hole on the base rail (row 4) and mark the bed.
5. Measure the distance of "C" from the centerline of the bed in both directions. The center of the bolt location will be at the intersection of A & C
6. Continue working toward the cab, marking the center holes of each remaining bolt locations. Note that two of the bolt locations are located at the intersection of "A" and the centerline of the bed on the rear base rail and another at the intersection of "B1" and the centerline of the bed on the front base rail (*optional for applications below 18K*).

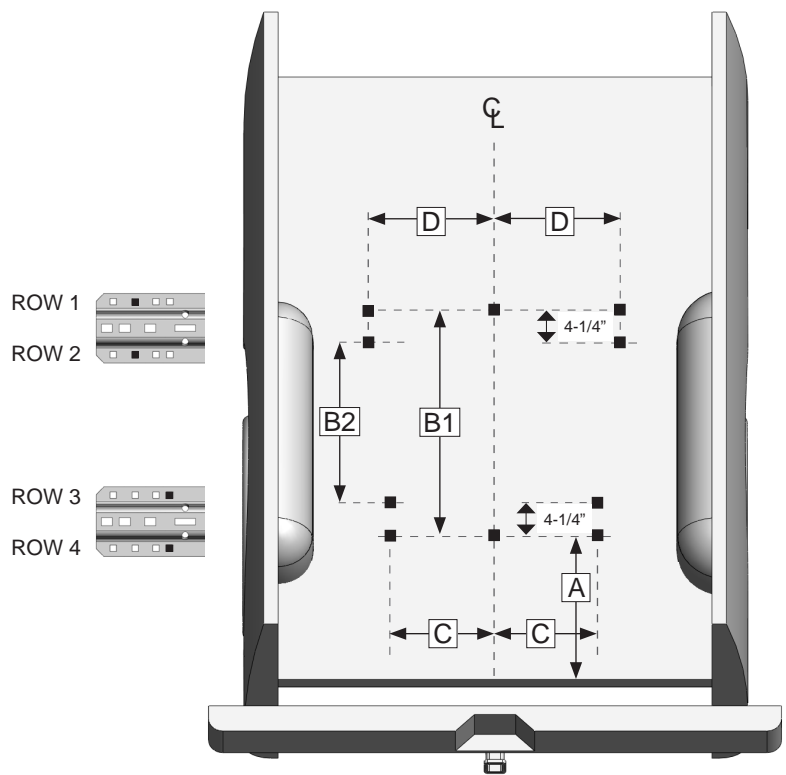

TRUCK BED DIMENSION TABLE							
LAYOUT METHOD					TEMPLATE METHOD		
BED LENGTH	"A"	"B1"	"B2"	"C"	"D"	"X"	Template part#
6 ft.	27-3/16"	26-5/16"	17-11/16"	15-3/4"	18-9/16"	26-1/2"	27200000
8 ft.	28-13/16"	26-5/16"	17-11/16"	15-3/4"	18-9/16"	28-1/8"	27200000

## TEMPLATE METHOD

1. Lay the template in the truck bed, centering it from side-to-side, and parallel to the end of the truck bed using the dimension "X" listed in "Truck Bed Dimension Table."
2. Mark the 10 holes, while making sure the template does not move.

**INSTALLATION TIPS:** The *TEMPLATE* should be orientated as shown in the drawing below. To avoid drilling holes in error from out of tolerance bed-to-frame dimensions, mark the hole locations as lightly as possible if a center or transfer punch is used. Then use a very small diameter drill bit to drill one location on either side of bed. Place the *Mounting Brackets* against the frame to determine the correctness of the bed hole locations relative to the pre-punched holes in the *Mounting Bracket* and existing frame holes. Adjust the template pattern relative to the end of the bed, as necessary, to move the bed holes nearer the center of the mounting bracket holes. Note also, the information etched into the template — the direction of the cab, the template number and the revision date. As one last measure, the template has a tendency to move when placed on the slick paint of new truck beds, and it may be helpful to place a small piece of *NON-SKID* matting, such as "SCOOT-GARD"™ or simply use duct tape on each corner to help keep the template from moving.

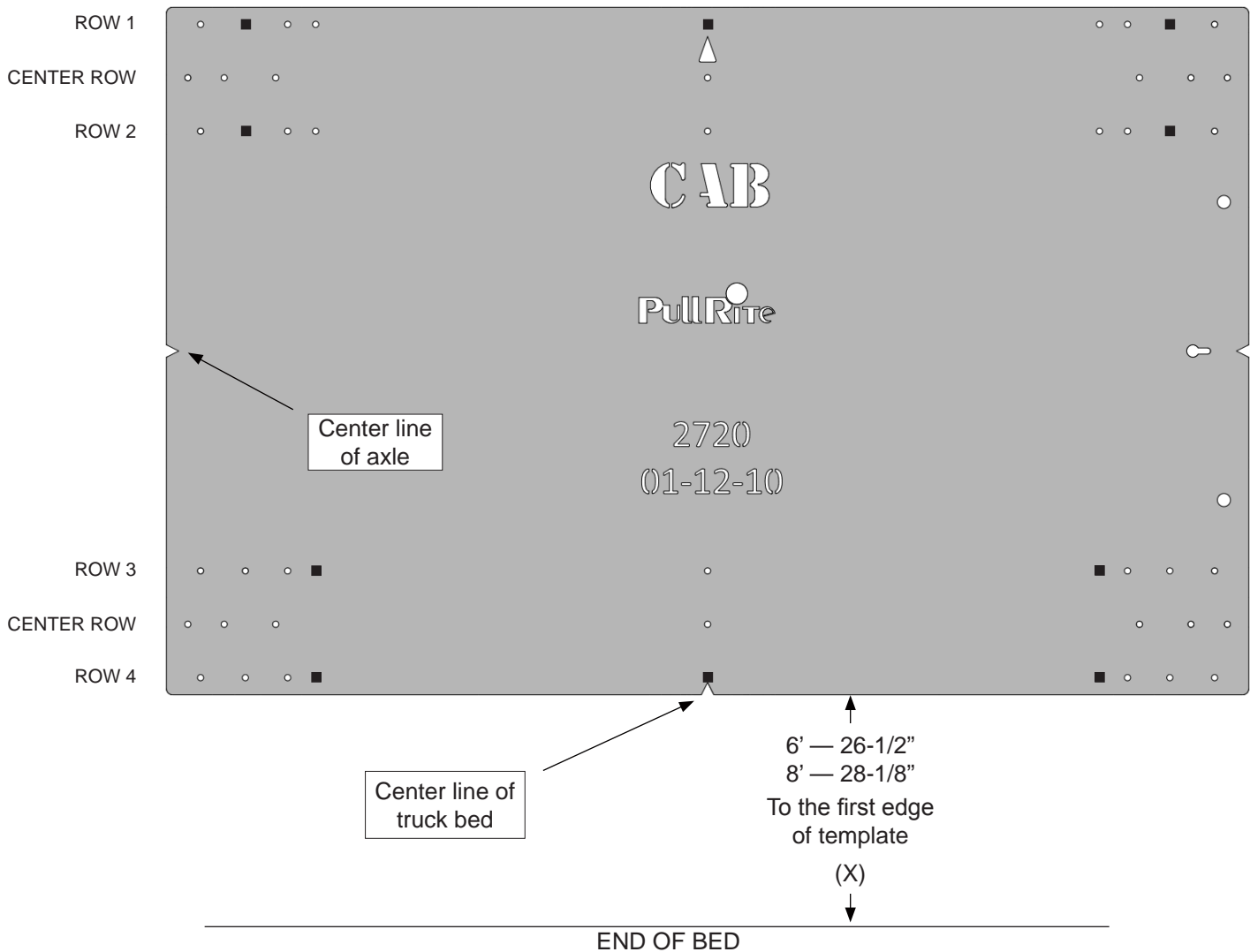



# INSTALLATION

## BRACKET PLACEMENT & BED HOLE LOCATIONS

Since most truck beds are not installed square to the frame or are the same distance from the back of the cab, the installer will need to make sure the bed holes line up properly with the center of each mounting bolt hole.

The basic steps in this section are as follows:

- Layout the bed holes
- Drill the first pilot hole in the bed
- Check centering
- Adjust the bed hole layout if necessary
- Drill the second pilot hole and check centering to ensure bed hole locations are square to the frame; adjust as needed
- Drill remaining pilot holes in the bed; check centering

## Detailed Installation Instructions

### FRONT MOUNTING BRACKET INSTALLATION

1. This is a no-drill bracket installation; the brackets are fastened around the truck's frame and through pre-existing holes in the truck frame. We suggest you read completely through these installation procedures, paying close attention to the fastening methods before proceeding.

**WARNING:** Prior to drilling any holes, be sure to check the inside of the frame to guard against drilling into the fuel tank, wiring, brake lines or fuel module.

2. Temporarily install both Front Mounting Brackets using the 1-1/2" Tap Bolts {N} and 1/2" Flat Washers {M}. This hardware will thread into welded nuts on the *inside* of the truck's enclosed frame in the pre-existing holes (*below*).
3. Drill five 1/16" pilot holes through the bed, and cross sill where applicable, required for locating the position of the front Base Rail {E}, verifying that the drill bit is centered front-to-back in the obround bolt holes on the top of each Mounting Bracket.
4. Once positioning has been achieved, remove the Mounting Brackets and drill the pilot holes out to 9/16" using a step drill (a step drill is a cone shaped bit that has a variety of gradually larger diameter sizes the deeper the drill is used – see below).

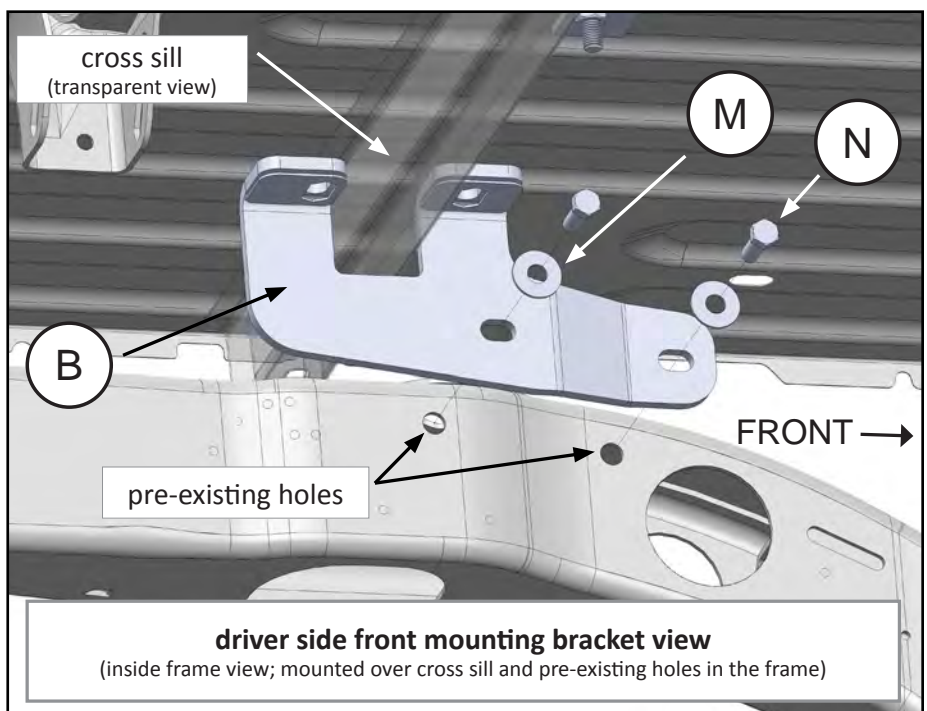

# INSTALLATION

5. Examine the Mounting Brackets and note that there is a 1/8" thick tab located just below the slotted bolt hole in the top plate of the Mounting Bracket (*above*). The purpose of this tab is to assist you in holding the Flange Nut {L} in place. To install, pry the "tab" down far enough so that a Flange Nut can be inserted, then push the "tab" back up into position. The Flange Nut should be able to slide in and out while the "tab" holds the nut in place. When fastening the Base Rails to the Mounting Brackets, the Flange Nut can easily be positioned under the square hole in the Base Rail using a pen or other small tool. When tightening the Base Rail Bolts with an impact gun, start slowly as the "tab" may otherwise "strip out". Install the Flange Nuts into the Front Mounting Bracket tabs.
6. Reinstall the mounting brackets to the frame with all required hardware. Hand tighten only.
7. To prevent "crushing" of the corrugated truck bed, we provide Base Rail Spacers {I} to be installed above and/or below the truck bed where necessary. Not all truck beds are installed exactly the same when manufactured, so *it is necessary for you to determine where to place your shims, relative to the bolt locations* (see Layout Method).
8. Install the front Base Rail and hardware on both driver and passenger sides of the vehicle as illustrated here (*right*) and on the "Mounting Kit Exploded View" drawing. A Center Hole Shim {J} must be installed below the bed for the center bolt.
9. Hand-tighten *only*, both Front Mounting Bracket Base Rail hardware.

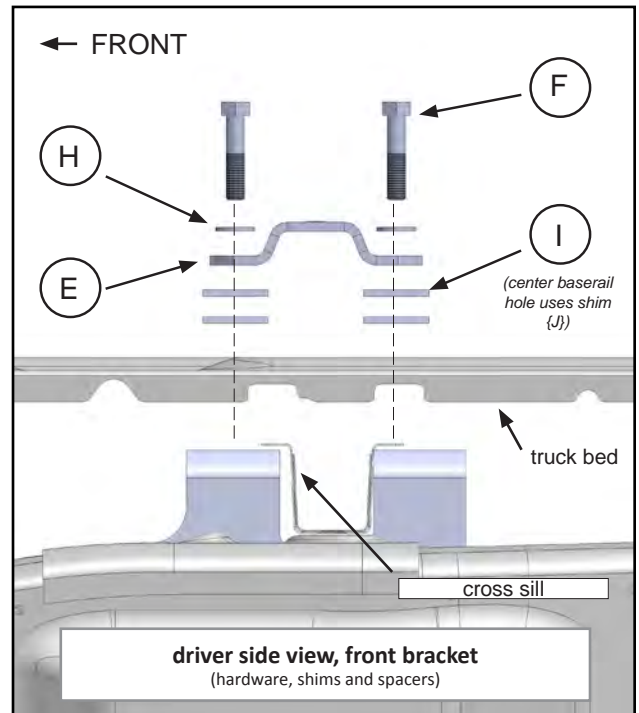
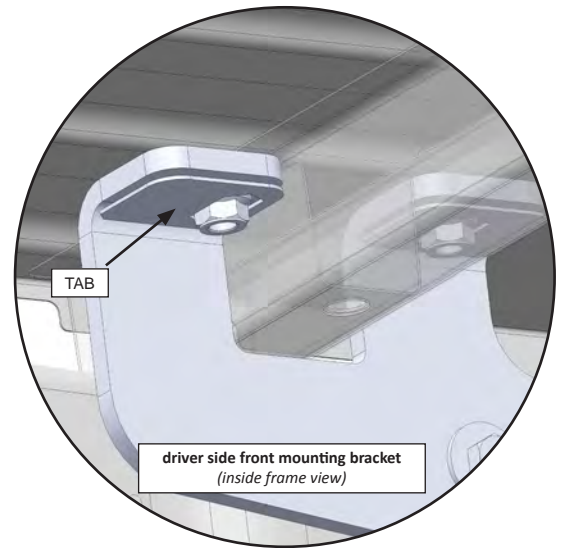



# INSTALLATION

## REAR MOUNTING BRACKET INSTALLATION

1. Verify the rail spacing dimensions for the rear base rails and marks made during “Marking the Bed for Drilling,” referencing the measurements based on the rear bed rails installed in the previous section. If the front base rail hole positions were adjusted during the Front Mounting Bracket installation, remember to adjust the rear holes accordingly before proceeding.

2. Drill the rear base rail pilot holes.

3. Both Rear Mounting Brackets are installed on the *inside* surface of the truck's frame.

4. Using the pre-existing holes in the truck frame as a guide, install the Driver Side Rear Mounting Bracket over the holes and adjacent to the nearby cross sill. Note the forward-most arm of the Driver Side Rear Mounting Bracket will sit underneath the cross sill (*right*).

5. Install the Passenger Side Rear Mounting Bracket in the same fashion as the Driver Side Bracket, using pre-existing holes and installed adjacent to the cross sill (*bottom right*).

6. Drill five 1/16” pilot holes through the bed, and cross sill where applicable, required for locating the position of the rear Base Rail {E}, verifying that the drill bit is centered front-to-back in the obround bolt holes on the top of each Mounting Bracket.

7. Once proper positioning has been achieved, remove both Mounting Brackets and drill the REAR-most pilot holes out to 9/16” using a step drill. The holes closest to the cab where the 4” Base Rail Bolt {G} will be installed is drilled out differently in the next step.

8. Drill out the FRONT-most pilot holes on the Base Rail nearest the cab to 9/16”, through the bed and

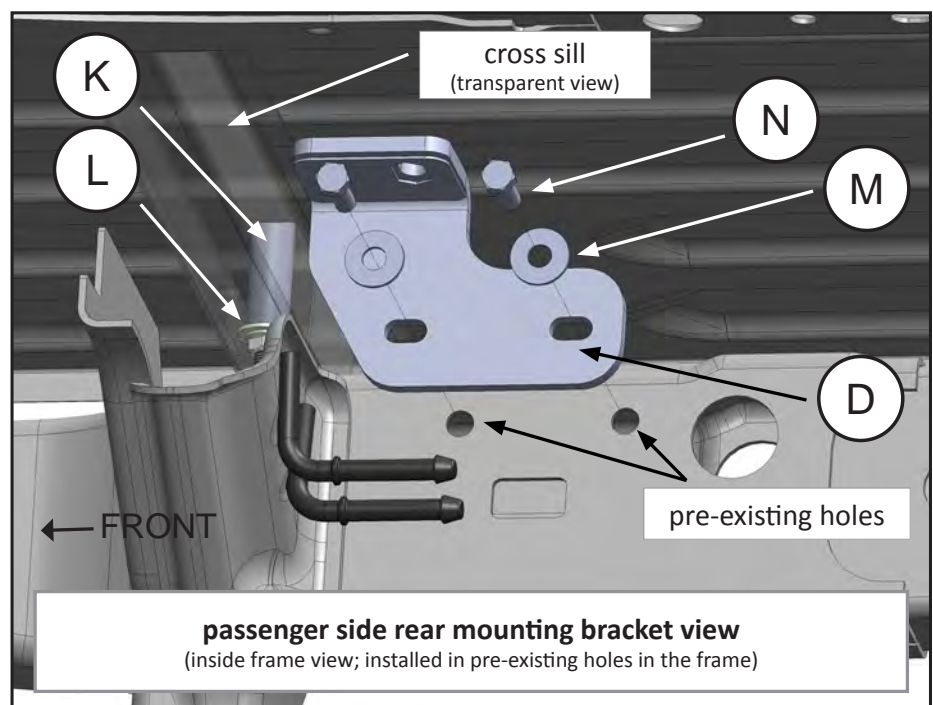
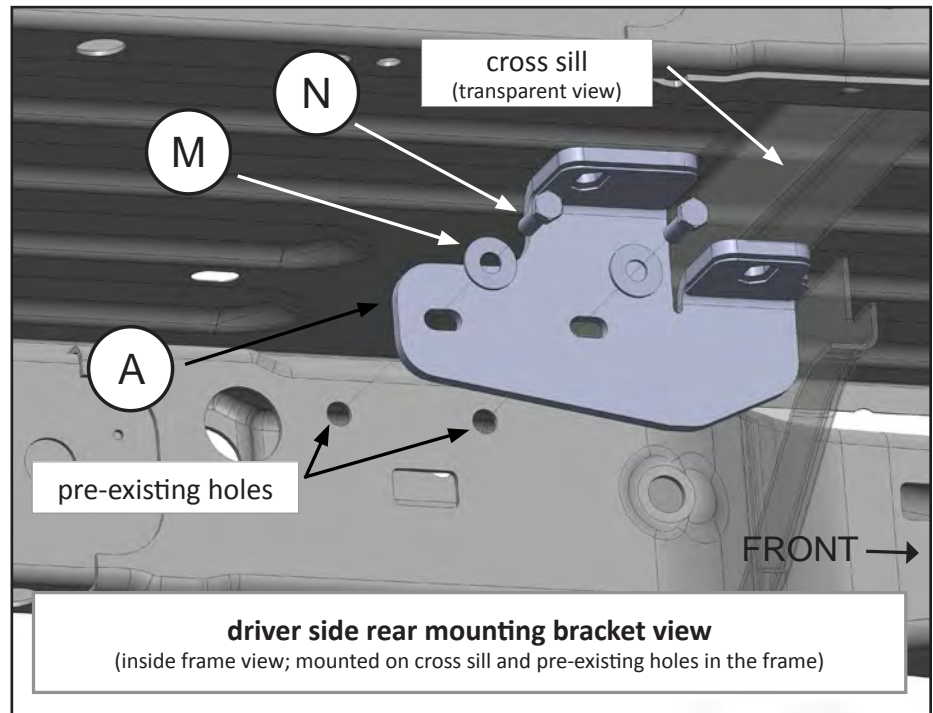

# INSTALLATION

bottom of the cross sill. This will allow the 4" Base Rail Bolt {G} to pass through the bottom of the cross sill, and into the top obround hole of the Driver Side Rear Mounting Bracket once installed.

- Using a step drill, enlarge the hole in the bed to 1-1/8", but DO NOT drill through the bottom cross sill again. We have provided Bed Channel Spacer Tubes {K} that will rest in that channel when installed.
- Install the Flange Nuts {L} into the Rear Mounting Bracket tabs as you did in the previous section for the Front Mounting Brackets.
- Install the rear Base Rail and hardware on both driver and passenger sides of the vehicle as illustrated here (*right*) and on the "Mounting Kit Exploded View" drawing. A Center Hole Shim {J} must be installed below the bed for the rear center bolt, and the Bed Channel Spacer Tubes {K} and required 4" Base Rail Bolt {G} are now installed into the cross sill.
- Hand-tighten *only*, both Rear Mounting Brackets and Base Rail hardware.

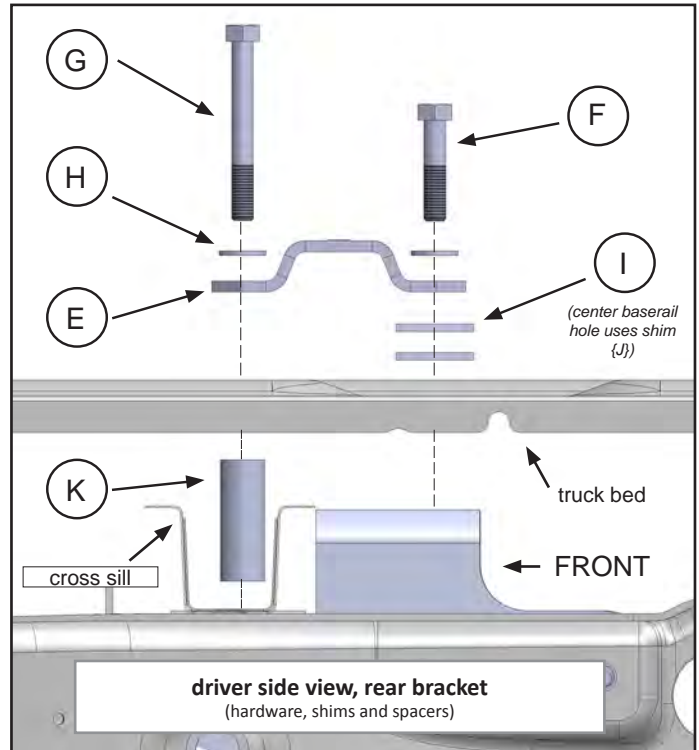

## FINAL INSTALLATION PROCEDURES

- Set the Industry Standard hitch on the base rails and align the hitch assembly with the mounting holes.
- Install the hitch pins and clips, to secure the hitch assembly to the base rails.
- Make certain the hitch comes on and off without binding prior to completing final torques.
- Tighten all bolts, including the base rail bolts, according to the Torque Table or until the Bracket begins to bend.

### TORQUE TABLE

3/8" bolt	— 31 ft. lbs.
1/2" bolt	— 75 ft. lbs.
M12 Bolt	— 94 ft. lbs.
5/8" bolt	— 151 ft. lbs.
3/4" bolt	— 266 ft. lbs.