

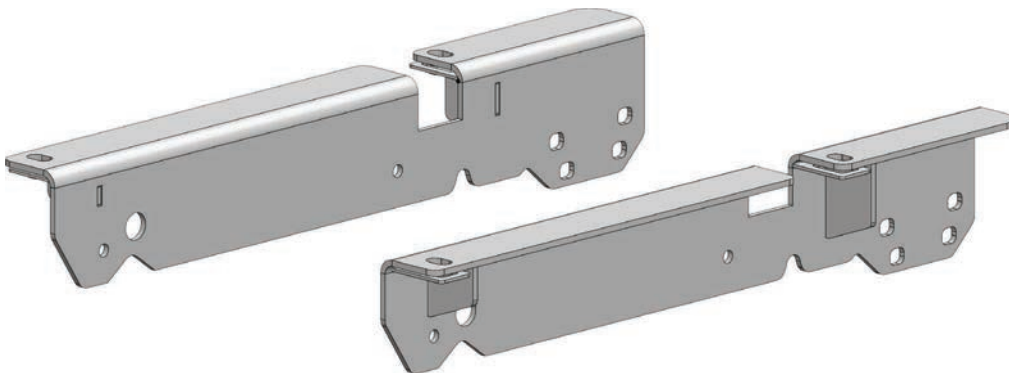

FORD

20K Industry Standard Rail Custom [Mounting Kit](#)

#2726



Gross Trailer Weight (Maximum).....20,000 lbs.
Vertical Load Weight (Max. Pin Weight).....5,000 lbs.

SYSTEM TOW CAPACITY

Please note, in order to determine the **total tow capacity** of a system, you must consider the weight ratings of each component in that system. This includes, but may not be limited to, the capacity/rating of the **tow vehicle**, the **fifth wheel hitch**, and the hitch's **mounting system**. Actual tow capacity of the system will be equal to the lowest rated component.

Installation Instructions

SPECIFICATIONS

- Fits 1999-2010 Ford F250 & F350 SuperDuty
 - Hitch is located center of the axle
- Custom Mounting Bracket Kit (*Bracket & Hardware*) #2727

PLATE ASSEMBLY

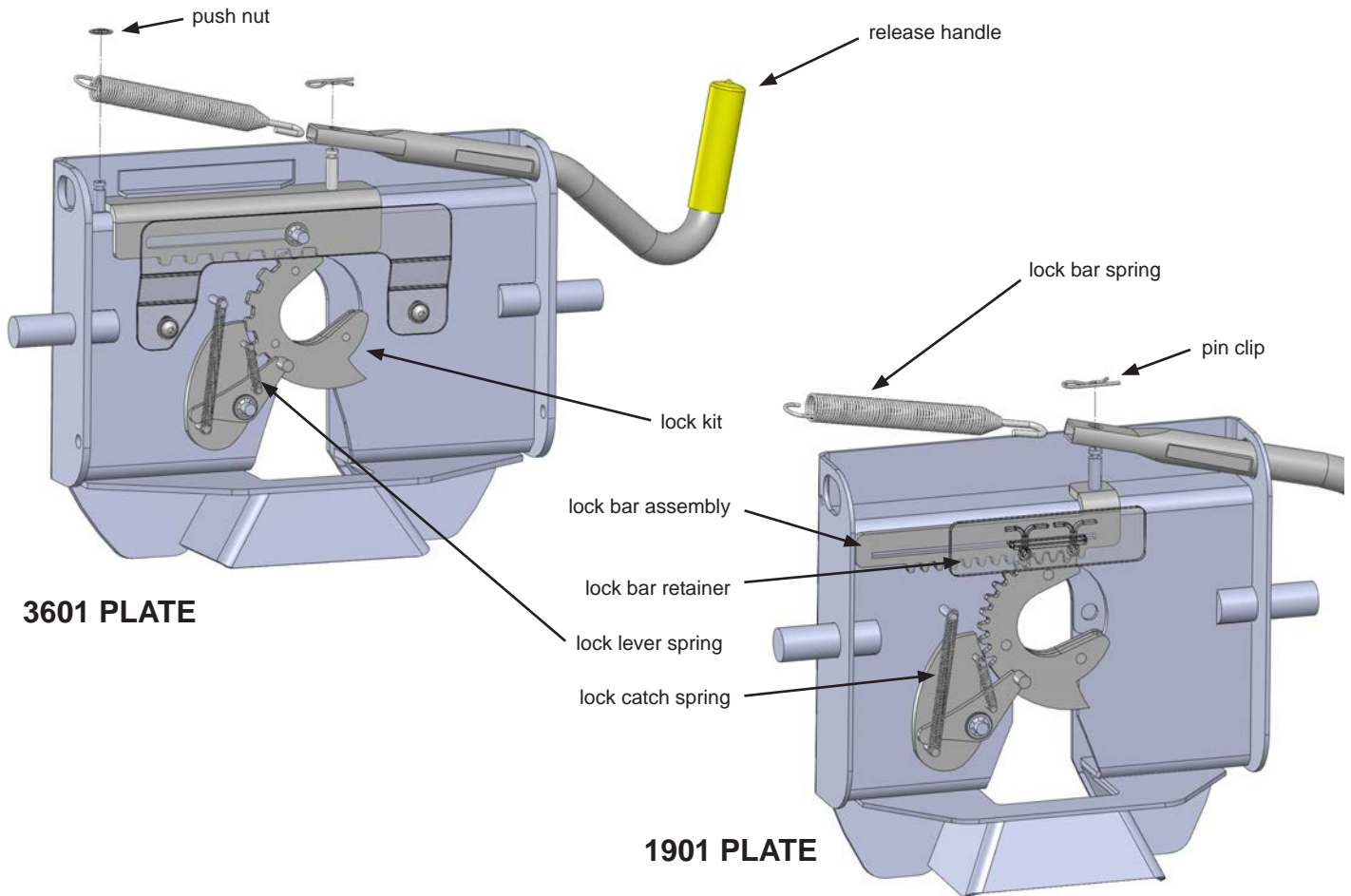

3601 PLATE

1901 PLATE

1. Remove the Fifth Wheel Plate from the Rocker Arm and place it upside down on a smooth, clean surface.
2. Insert the Release Handle into the obround hole of the plate as seen above.
3. The Lock Bar Spring must be placed inside the handle prior to placing the handle down over the pin of the Lock Bar Assembly, "catching" the hook inside the handle around the pin.
4. Push the handle and spring assembly down past the groove in the pin of the Lock Bar Assembly, and place one of the Pin Clips in the groove of the pin to fasten.
5. Grip the body of the spring and stretch it far enough over the opposite pin (welded to the plate) and push it down past the groove.
6. Install the Push Nut to secure the Lock Bar Spring onto the welded pin.

NOTE: The 1901 plate for the #1900 Super 5th does not use a push nut to attach the end of the spring, but rather a slot in the side of the fifth wheel plate located above the obround hole. See illustration to the right.

As a PullRite fifth wheel hitch owner, it is important for you to study and manually operate the Fifth Wheel Plate and Release Handle to better understand the locking action. A better working knowledge of the plate will help prevent accidental dropping of your trailer due to incorrect hitching.

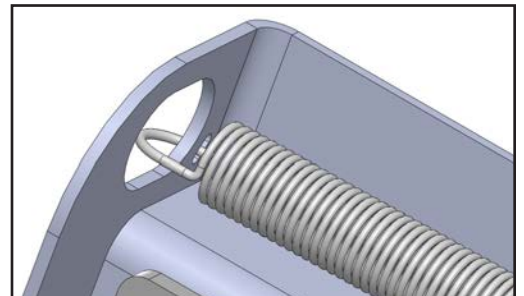

Also, it is imperative that you study and adhere to the Maintenance procedures provided in the Owners Manual.

MOUNTING KIT EXPLODED VIEW

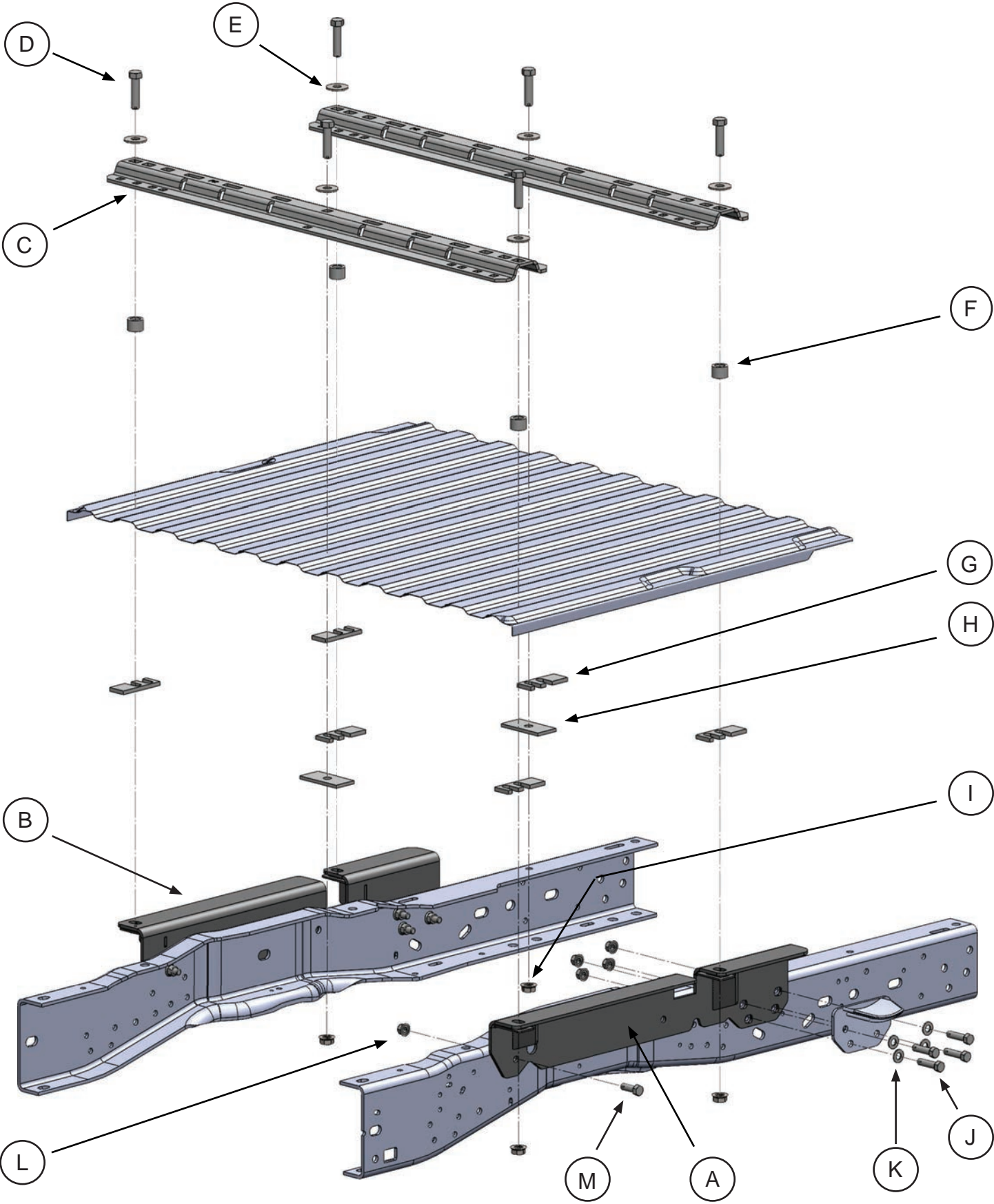

MOUNTING KIT PARTS LIST

#2726 FORD CUSTOM ISR BRACKET KIT

description	part no.	qty	material
MOUNTING BRACKET KIT	2727	1	(See kit contents listed below)
BASE RAIL KIT	2719	1	(See kit contents listed below)

#2727 — MOUNTING BRACKET KIT

item	description	part no.	qty.	material
A	DRIVER SIDE MOUNTING BRACKET	272701	1	
B	PASSENGER SIDE MOUNTING BRACKET	272702	1	
	MOUNTING BRACKET HARDWARE KIT	272703	1	(See kit contents listed below)

#272703 — MOUNTING BRACKET HARDWARE KIT

item	description	part no.	qty.	material
D	BASE RAIL MOUNTING BOLTS	98010217	6	5/8"-11 X 3" HHCS GRD 5
E	5/8" CONICAL WASHER	98200171	6	5/8" EXT. TOOTH CONICAL WASHER
F	BASE RAIL SPACER TUBE	27210204	4	
G	DOUBLE SLOTTED BED SHIM	27210202	6	
H	CENTER HOLE BED SHIM	27210203	2	
I	5/8" FLANGE NUT	98150200	6	5/8"-11 SERRATED FLANGE NUT
J	2" MOUNTING BOLT	98010175	8	1/2"-13 X 2" HHCS GRD 5
K	1/2" FLAT WASHER	98250145	8	1/2" FLAT WASHER
L	1/2" FLANGE NUT	98150201	10	1/2"-13 SERRATED FLANGE NUT
M	1-1/2" MOUNTING BOLT	98010167	2	1/2"-13 X 1-1/2" HHCS GRD 5

#2719 — BASE RAIL KIT

item	description	part no.	qty.	material
C	BASE RAILS	27190001	2	

LAYOUT TEMPLATE

description	part no.	qty.	material
LAYOUT BED TEMPLATE	27200000	1	ITEM SOLD SEPARATELY

TRUCK PREPARATION

1. Block vehicle wheels. Some vehicles may require you to raise the rear of the truck to install the mounting brackets on the truck frame.
2. You may wish to remove the wheels to give yourself greater working room.
3. Carefully remove the plastic inner wheel well guards on both sides of the vehicle (*not applicable to some models*).
4. If your vehicle is equipped with an overload spring bracket, remove the bracket and retain the factory bolts for later use.
5. Remove the spare tire. This will allow easy access to the inside of the truck frame. The fender support at the front of the wheel well may also need to be removed, in order to drill front hole location.
6. Unfasten the bolt (15 mm) that holds the emergency brake cable to the frame on the drivers side.

MARKING THE TRUCK BED FOR DRILLING

LAYOUT METHOD

If you purchased an installation template, please proceed to "TEMPLATE METHOD". *Templates are sold separately.*

1. Referencing "Truck Bed Dimension Table" and the illustration to the right, measure and mark from the back of the bed forward, the value for "A." Do this at any point on *both* sides of the bed and draw a line across the bed from mark to mark.
2. Find the centerline of the bed.
3. Draw a line down the middle of the bed from front-to-rear.
4. The intersection of "A" and the centerline of the bed is the center hole location of bolts on the center row of the base rail. Starting at this intersection, measure the distance of "C" in both directions to find the remaining bolt hole locations.
5. Continue working toward the cab, marking the distance "B" as the distance between both center rows of the base rails.

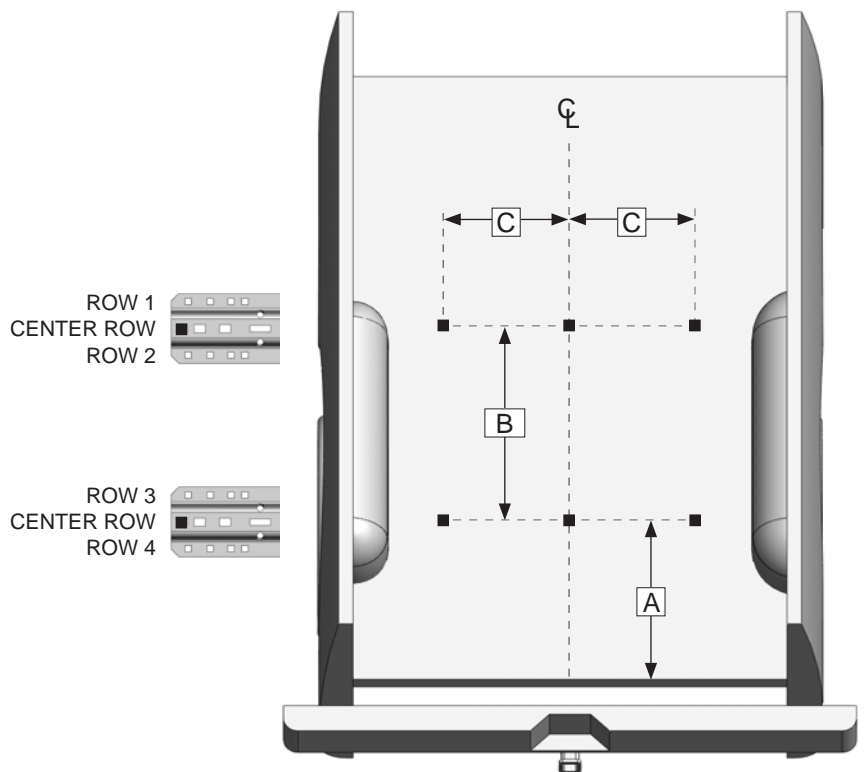

TRUCK BED DIMENSION TABLE				
LAYOUT METHOD			TEMPLATE METHOD	
"A"	"B"	"C"	"X"	Template part#
33-1/8"	22"	20-7/8"	30-3/8"	27200000

TEMPLATE METHOD

1. Lay the template in the truck bed, centering it from side-to-side, and parallel to the end of the truck bed using the dimension "X" listed in "Truck Bed Dimension Table."
2. Mark the 6 holes, while making sure the template does not move.

INSTALLATION TIPS: The *TEMPLATE* should be orientated as shown in the drawing below. To avoid drilling holes in error from out of tolerance bed-to-frame dimensions, mark the hole locations as lightly as possible if a center or transfer punch is used. Then use a very small diameter drill bit to drill one location on either side of bed. Place the *Mounting Brackets* against the frame to determine the correctness of the bed hole locations relative to the pre-punched holes in the *Mounting Bracket* and existing frame holes. Adjust the template pattern relative to the end of the bed, as necessary, to move the bed holes nearer the center of the mounting bracket holes. Note also, the information etched into the template — the direction of the cab, the template number and the revision date. As one last measure, the template has a tendency to move when placed on the slick paint of new truck beds, and it may be helpful to place a small piece of *NON-SKID* matting, such as "SCOOT-GARD"™ or simply use duct tape on each corner to help keep the template from moving.

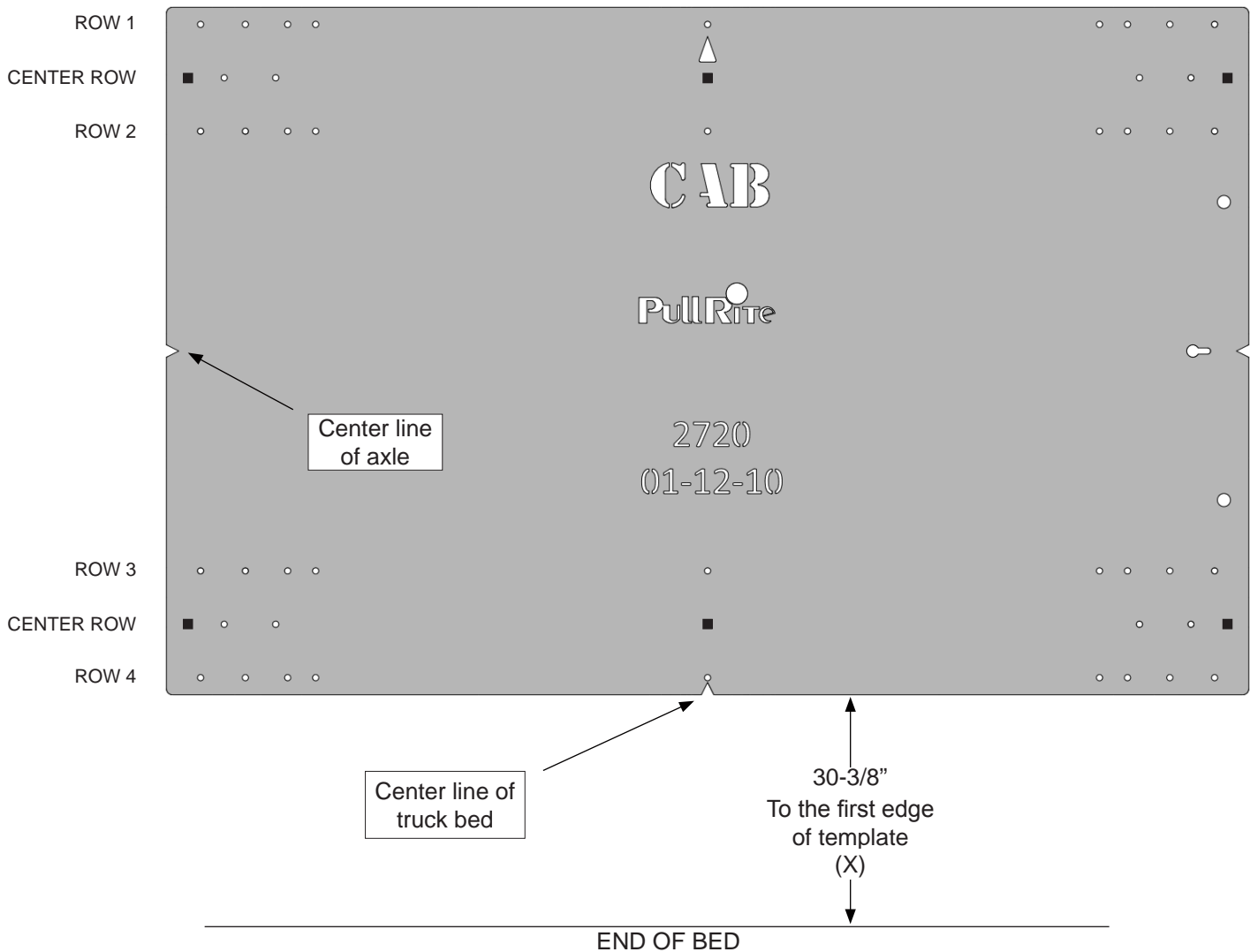

INSTALLATION

PART 1 — BRACKET PLACEMENT & BED HOLE LOCATIONS

Since most truck beds are not installed square to the frame or are the same distance from the back of the cab, the installer will need to make sure the bed holes line up properly with the center of each mounting bolt hole.

The basic steps in this section are as follows:

- Layout the bed holes
- Drill the first pilot hole in the bed
- Check centering
- Adjust the bed hole layout, if necessary
- Drill the second pilot hole and check centering to ensure bed hole locations are square to the frame; adjust as needed
- Drill remaining pilot holes in the bed; check centering
- Drill truck frame, if necessary

Detailed Installation Instructions

1. Line up the four rear holes on the mounting bracket with the four overload bracket holes. The front hole on the driver and passenger side mounting brackets require a 1/2" hole to be drilled. If your truck has an overload bracket, remove it, and sandwich the mounting bracket between the frame and overload bracket as shown below.

NOTE: If the vehicle is equipped with overload springs, the same fasteners used to originally mount the over load bumpers can be used to fasten the rear of the Mounting Bracket and the over load bumper (see below). If the vehicle is not equipped with over load springs then the holes in the frame must be drilled out using a 1/2" drill bit.

2. The holes at {M} may be too small for the 1/2" bolts provided or may not be pre-existing and must be drilled out to a 1/2" diameter. Refer to the illustration below.
3. Using the pre-punched bracket holes as a guide, position the Driver Side Mounting Bracket on the frame and clamp or fasten in place to determine if your bed layout marks are square to the frame, making sure the bracket is tight against the frame (some mounting brackets may have a slight warp due to the metal characteristics during the welding process).

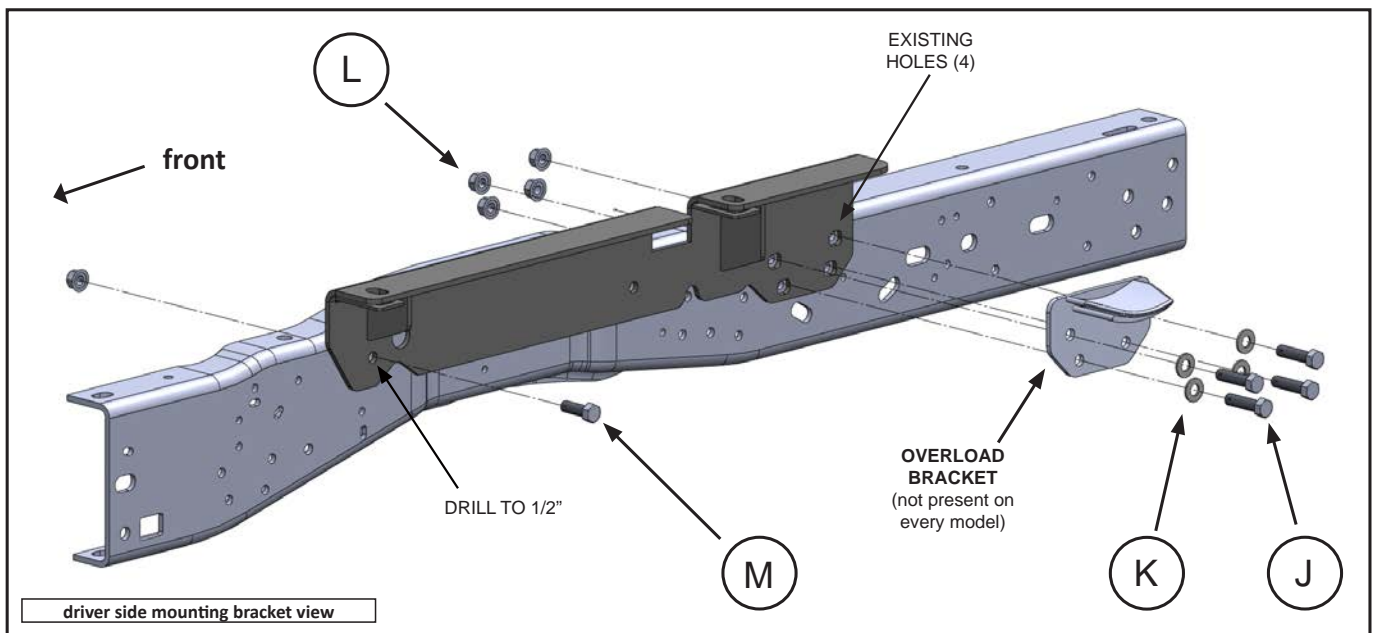

INSTALLATION

WARNING: Prior to drilling any holes, be sure to check the inside of the frame to guard against drilling in to the fuel tank, wiring, brake lines or fuel modules.

4. Drill the first 1/16" pilot hole through the truck bed over the rear hole of the Driver Side Mounting Bracket where you made the mark during the "Marking Bed for Drilling."
5. Keep the drill bit in the pilot hole and check for centering front-to-back in the slotted bolt holes of the bracket (see below).
6. Repeat Steps 4 and 5 for the front hole of the mounting bracket.
7. Repeat Steps 1-6 for the Passenger Side Mounting Bracket.

NOTE: Some truck beds are not installed square on their frame by the manufacturer. To ensure your pilot holes are aligned properly, it is important that you use the measurements provided only as a starting point and make adjustments as needed. Once the rear driver side pilot hole is centered, you will use this hole as a point of reference for all remaining pilot hole adjustments. If you are using the Template Method, simply use the properly drilled hole as a pivot point to square the remaining holes to the frame. If you are using the Layout Method, you may accomplish the same thing by using a framing square and straight edge.

8. Using the pre-punched mounting bracket holes as a guide, drill a 1/2" hole through the wall of the frame at {M} for both Driver and Passenger Side Brackets (if needed).
9. Remove both mounting brackets from the frame and drill out all pilot holes with a step drill to 3/4".

INSTALLATION

PART 2 — BRACKET INSTALLATION

1. Examine the Mounting Brackets and note that there is a 1/8" thick tab located just below the slotted bolt hole in the top plate of the Mounting Bracket (see right). The purpose of this tab is to assist you in holding the Flange Nut {I} in place. To install, pry the "tab" down far enough so that a Flange Nut {I} can be inserted, then push the "tab" back up into position. The Flange Nut should be able to slide in and out while the "tab" holds the nut in place. When fastening the Base Rails to the Mounting Brackets, the Flange Nut can easily be positioned under the square hole in the Base Rail using a pen or other small tool. When tightening the Base Rail Bolts {D} with an impact gun, start slowly as the "tab" may otherwise "strip out."
2. Using a clamp, place the driver side mounting bracket over the holes in the frame, making sure it is flush with the side of the frame.
3. Insert the four, 1/2"-13 x 2" {J} and flat washers {K} through the bracket, overload bracket (if applicable, reinstall original fasteners), and frame. Hand tighten only.
4. Insert the 1/2" - 13 x 1-1/2" {M} through the bracket and frame. Hand tighten only.
5. Repeat steps 2-4 for the passenger side Mounting Bracket.

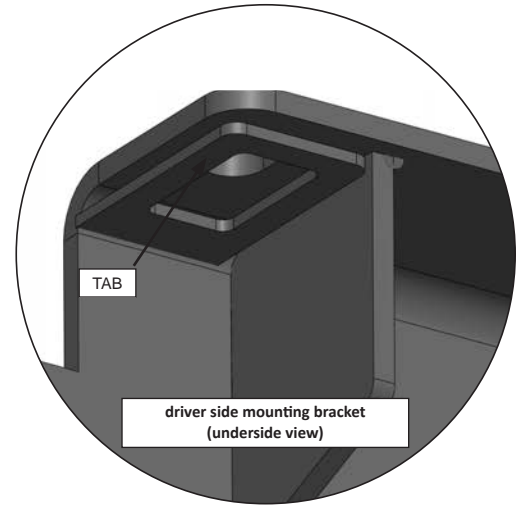

PART 3 — SHIMMING THE BED

1. To prevent "crushing" of the corrugated truck bed, we provide shims and backup plates to be installed above and/or below the truck bed where necessary. Not all truck beds are installed exactly the same when manufactured, so it is necessary for you to determine where to place your shims, relative to the bolt locations (see Layout Method).
2. If you find that a bolt hole location is located over a bed channel, you may need to use a Double Slotted Bed Shim {G} or a Base Rail Spacer Tube {F} to fill the space so it is even with the top of the bed. Conversely, do the same if the channel is located on the underside of the bed if necessary.

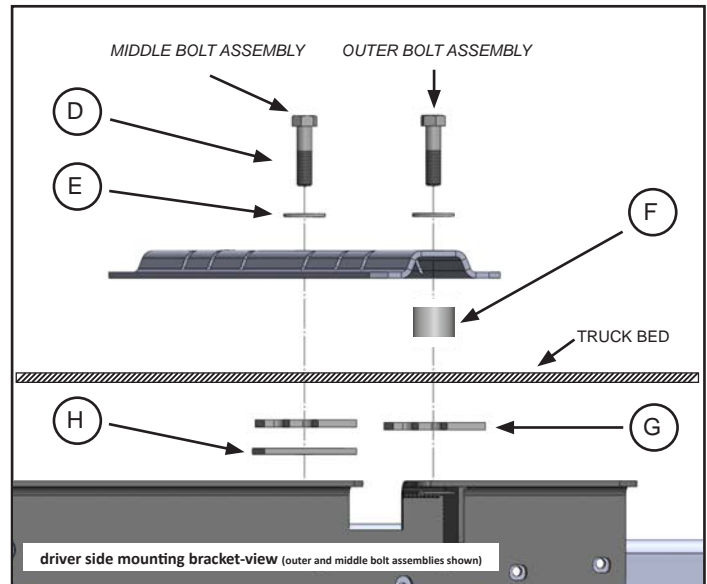

PART 4 — FINAL INSTALLATION PROCEDURES

1. Set the hitch on the Industry Standard Rails by centering the tabs on the bottom of the hitch into the slots on the rails.
2. Install the hitch pins through the side of the base rails to secure the hitch assembly to the base rails using the supplied pin clips.
3. Make certain the hitch comes on and off without binding prior to completing final torques.
4. Tighten all bolts, including the base rail bolts, according to the Torque Table.

TORQUE TABLE	
3/8" bolt	— 31 ft. lbs.
1/2" bolt	— 75 ft. lbs.
5/8" bolt	— 151 ft. lbs.
3/4" bolt	— 266 ft. lbs.