



OWNER'S MANUAL



#1900 (16K) Industry Standard Super 5th

Gross Trailer Weight (Maximum) 16,000 lbs.
Vertical Load Weight (Max. Pin Weight) 4,000 lbs.



#2100 (20K) Industry Standard Super 5th

Gross Trailer Weight (Maximum) 20,000 lbs.
Vertical Load Weight (Max. Pin Weight) 5,000 lbs.



#2200 (24K) Industry Standard Super 5th

Gross Trailer Weight (Maximum) 24,000 lbs.
Vertical Load Weight (Max. Pin Weight) 6,000 lbs.

The following instructions provide valuable information regarding the function and proper use of the Super [5th Wheel Towing System](#).

YOU MUST COMPLETELY READ THE INSTRUCTIONS WITHIN THIS MANUAL, PRIOR TO OPERATING THE HITCH TO PREVENT UNNECESSARY DAMAGE TO THE HITCH, VEHICLE, OR TRAILER.

SYSTEM WEIGHT RATING vs. COMPONENT WEIGHT RATING

A towing system includes each vehicle and component involved in towing. Each item in your towing system has a capacity or weight rating. Your trailer has a Gross Vehicle Weight Rating, or GVWR. Your truck has a tow capacity, payload capacity, and possibly more. In addition, your fifth wheel hitch has a weight rating. This weight rating must be at, or above, the GVWR of your trailer for you to tow safely. In addition, if your truck can tow larger loads (has a larger capacity) than the rating of your hitch, your system is only safe to tow loads at the lower rating, that of the hitch.

Your mounting kit also has a weight rating, just like your fifth wheel hitch. Many times, these ratings are designed to match. But, this is not always the case. Your mounting kit may be higher rated than your fifth wheel hitch, but it also could be lower depending on the components involved. **The lowest rating of any one component in the system becomes the rating of the entire system.** If your mounting kit is rated to 18,000 lbs., and your hitch is rated at 24,000 lbs., the weight rating of the entire system will not be above 18,000 lbs. Other components in the system could lower the actual system rating further.

It is the end user's responsibility to ensure a safe towing experience. To this end, it is your responsibility to ensure that the truck, trailer, hitching components, and all other items involved are rated or have a capacity sufficient for the loads involved.

LUBRICATION

DO NOT OPERATE HITCH UNTIL YOU READ THIS SECTION!

FIFTH WHEEL PLATE & KING PIN

The plate and its moving parts should be lubricated with a light lubricant such as WD-40 or 3-in-1 oil, before each trip or as needed. Be sure the plate is free of dirt and old oil buildup. Pull the Release Handle repeatedly so that the lubricant will spread among the moving parts that may not have otherwise been covered sufficiently.

Be sure the trailer's king pin is clean and free from rust. A light coating of WD-40 or other similar lubricant should be used on the king pin.

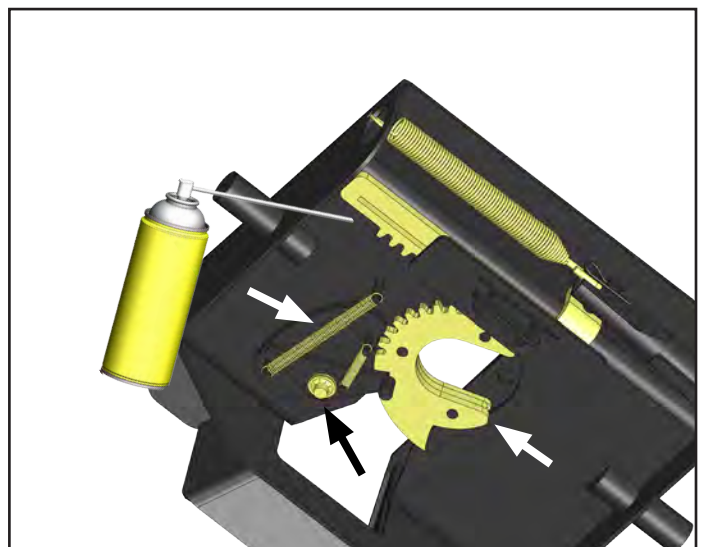

1901 plate pictured above

LUBRICATION

PIVOT BOLT & HITCH PINS

Inspect and lubricate the Pivot Bolt monthly with axle grease when heavily used, or annually with light use. To remove the pivot bolt for lubrication:

1. Remove the Fifth Wheel Plate from the Rocker Arm.
2. Remove the Hex Nut, Lock Washer and Plastic Washers from the Rocker Arm Pivot Bolt.
3. Place downward force, compressing the Rocker Arm Spring, enabling the Pivot Bolt to be removed.
4. Lube the Pivot Bolt generously with a quality axle grease and reinstall. Tighten the Pivot Bolt to the point where there is resistance when you move the Rocker Arm side-to-side.
5. A light coating of lubricant on the hitch pins (*below*) and pin clips will help you install and reinstall them easily.

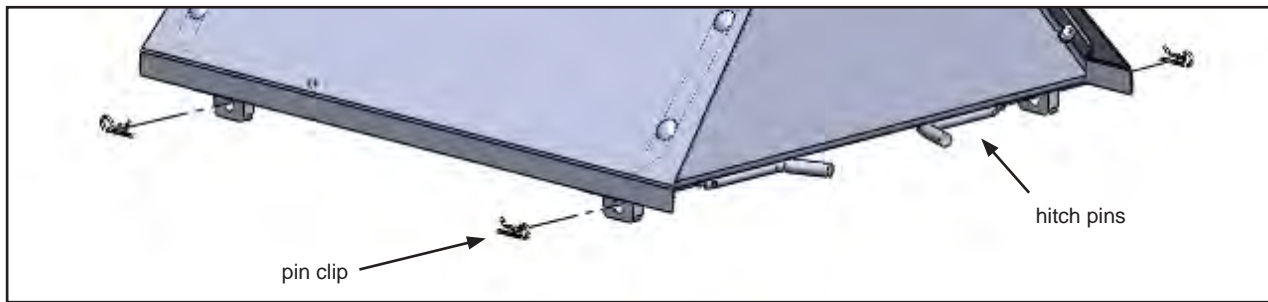
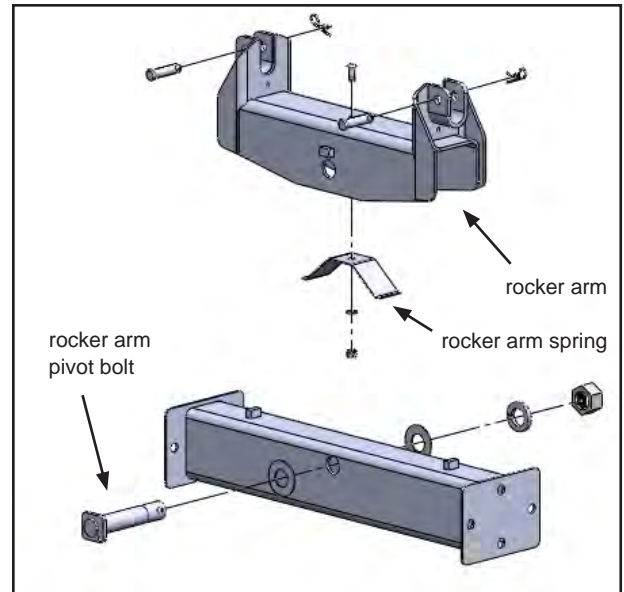

ANNUAL MAINTENANCE

Inspect all mounting bracket and hitch hardware, that it is securely fastened. The Fifth Wheel Plate should be removed and inspected, checking all moving parts for wear—clean as directed above. Inspect all mounting bolts for tightness and general condition.

When storing your Super 5th hitch, you should be sure that the Fifth Wheel Plate parts are lubricated with WD-40 to retard the formation of rust. Cover the entire assembly to prevent accumulation of dirt, grime, or rust.

CAUTION

- The Super 5th hitch is equipped with a side-to-side pivot feature. There should be a minimum of 6" between the truck bed rails and the under side of the trailer for side tilt clearance. It is the customers responsibility to adjust the trailer king pin box for the appropriate amount of clearance depending on the terrain being traveled (example: some State Parks are sloped and unpaved; some driveways are steeply angled). If after-market bed covers are added, care must be taken to allow for additional clearance.

FIFTH WHEEL PLATE ASSEMBLY

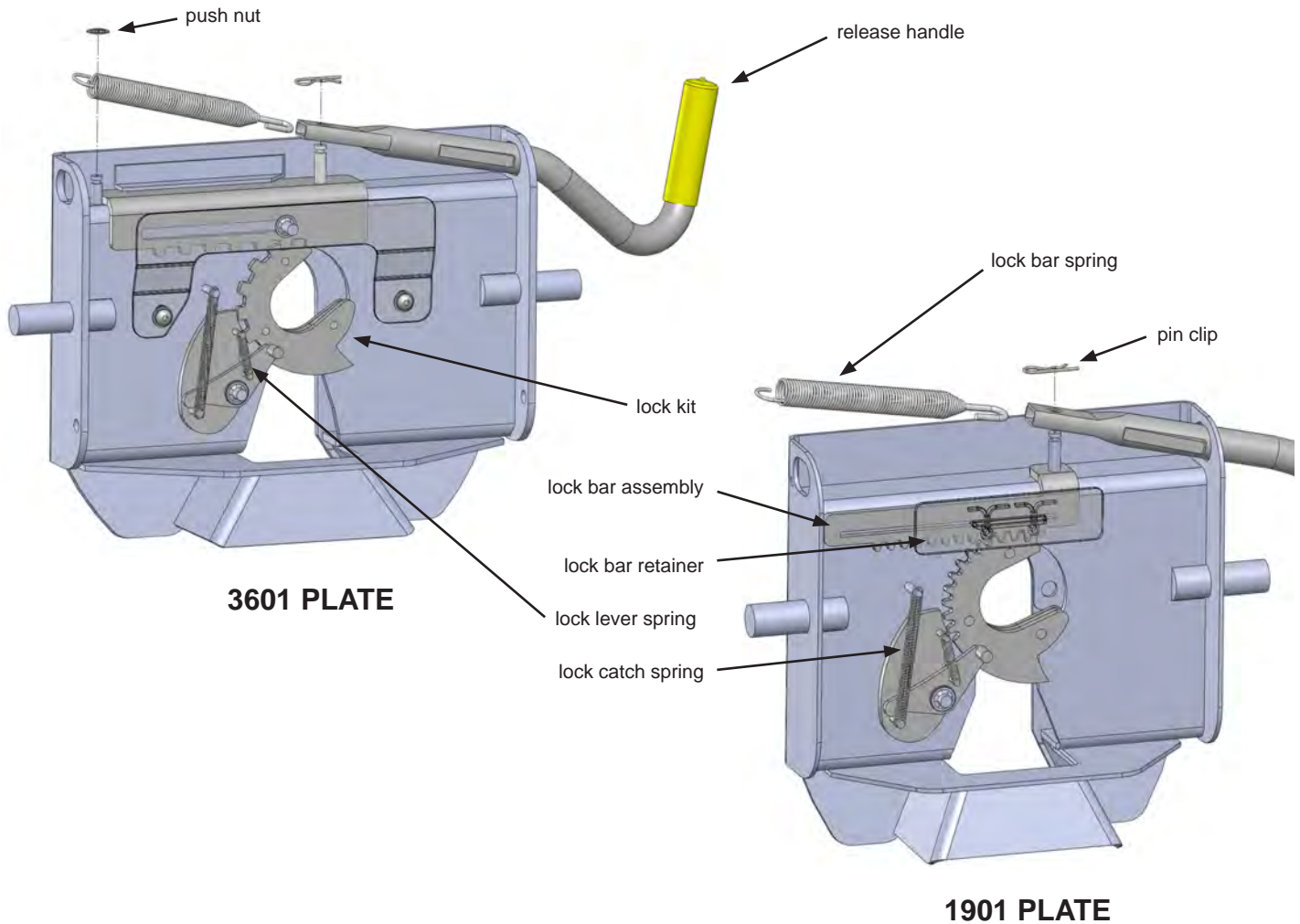

1. Remove the Fifth Wheel Plate from the Rocker Arm and place it upside down on a smooth, clean surface.
2. Insert the Release Handle into the obround hole of the plate as seen above.
3. The Lock Bar Spring must be placed inside the handle prior to placing the handle down over the pin of the Lock Bar Assembly, "catching" the hook inside the handle around the pin.
4. Push the handle and spring assembly down past the groove in the pin of the Lock Bar Assembly, and place one of the Pin Clips in the groove of the pin to fasten.
5. Grip the body of the spring and stretch it far enough over the opposite pin (welded to the plate) and push it down past the groove.
6. Install the Push Nut to secure the Lock Bar Spring onto the welded pin.

NOTE: The 1901 plate for the #1900 Super 5th does not use a push nut to attach the end of the spring, but rather a slot in the side of the fifth wheel plate located above the obround hole. See illustration to the right.

As a PullRite fifth wheel hitch owner, it is important for you to study and manually operate the Fifth Wheel Plate and Release Handle to better understand the locking action. A better working knowledge of the plate will help prevent accidental dropping of your trailer due to incorrect hitching.

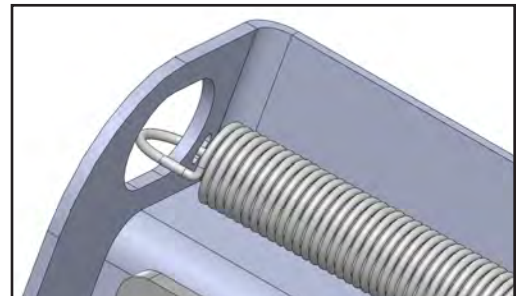

Also, it is imperative that you study and adhere to the Maintenance procedures provided in the Owners Manual.

FIFTH WHEEL PLATE OPERATION

A better understanding of the plates locking and un-locking operation can be obtained by viewing the working parts from the underside of the plate. The Fifth Wheel Plate can be removed and turned over to view the workings of the mechanism. When operating the Fifth Wheel Plate manually, please be aware that the Lock Jaw Assembly has more movement capability when there is not a king pin present to center the assembly. Refer to the illustrations below for part identification (#3601 plate pictured below; #1900 Super 5th uses plate #1901, but both function similarly).

1. To open the locking mechanism, lift and pull the Release Handle out until the Lock Catch engages the Lock Jaw Assembly (see illustrations on the opposite page).
2. As the trailer king pin moves into the plate, it will contact the Lock Lever, forcing the Lock Catch to disengage the Lock Jaw Assembly, allowing the Lock Bar Spring to close the Lock Jaw Assembly behind the King Pin. The King Pin must be fully engaged in the plate slot or the Lock Jaw Assembly will not seat properly, and the Handle Catch would not then engage the inner side wall of the plate. To be certain that the Lock Jaw Assembly has closed fully, attempt to pull the Release Handle without first lifting it.

NOTE: Please note that when lifting the handle to clear the side wall of the plate with the handle catch, it will be necessary to pull with some force to begin the Lock Jaw rotation. Merely lifting the Release Handle will not cause the Handle to “pop” open and rotate the Lock Jaw to the open position.

3. To discourage theft or pranksters, place a padlock through the obround hole *above* the Release Handle (see Illustration below).

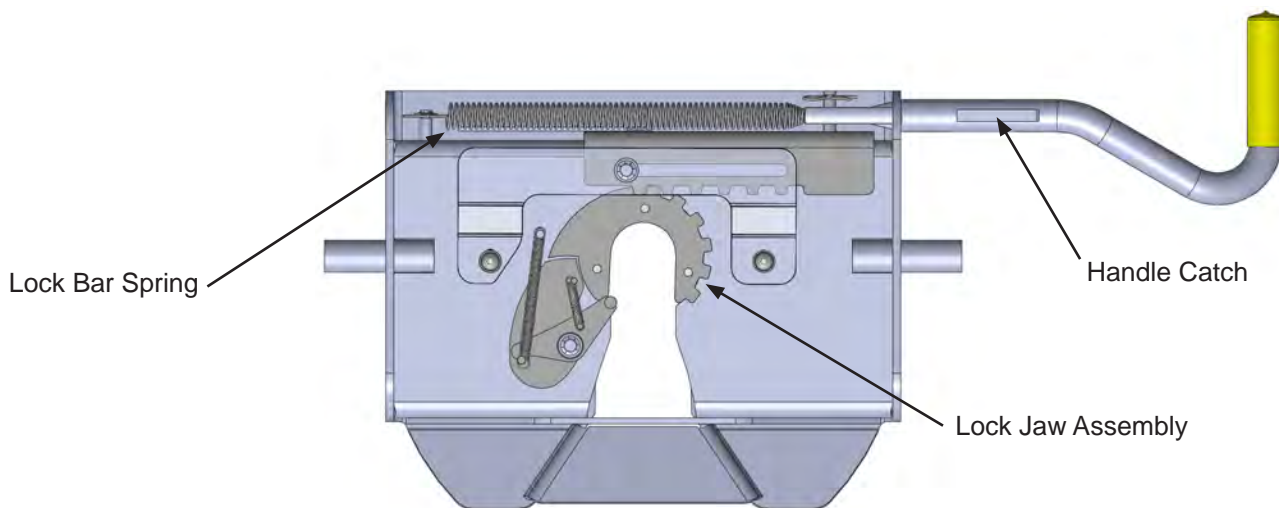

OPEN -- UNLOCKED POSITION

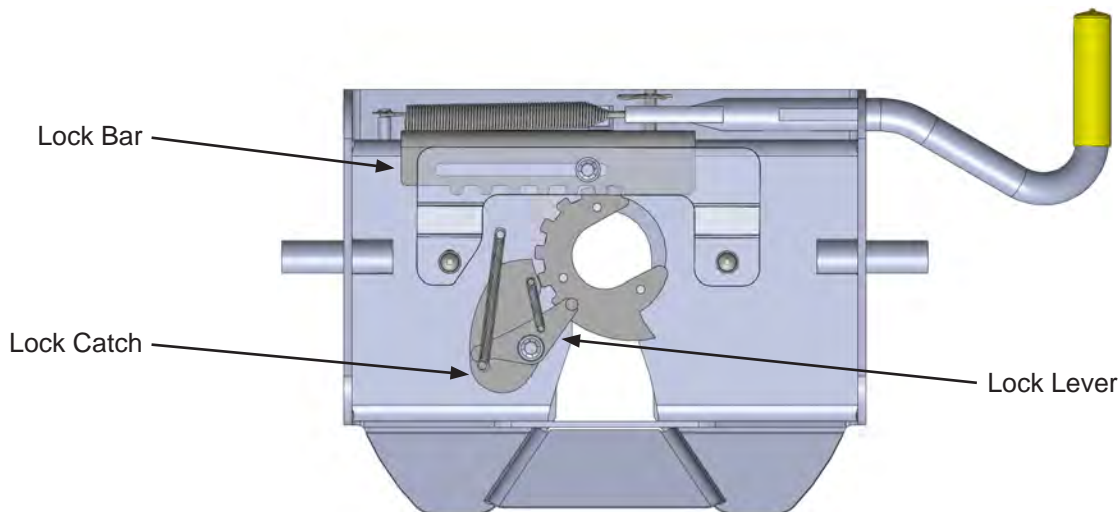

CLOSED -- LOCKED POSITION

FIFTH WHEEL PLATE OPERATION

CAUTION: DO NOT ATTEMPT TO TRIP THE LOCK MECHANISM WITH YOUR HAND. USE A PROBE DEVICE TO SIMULATE THE KING PIN ACTION

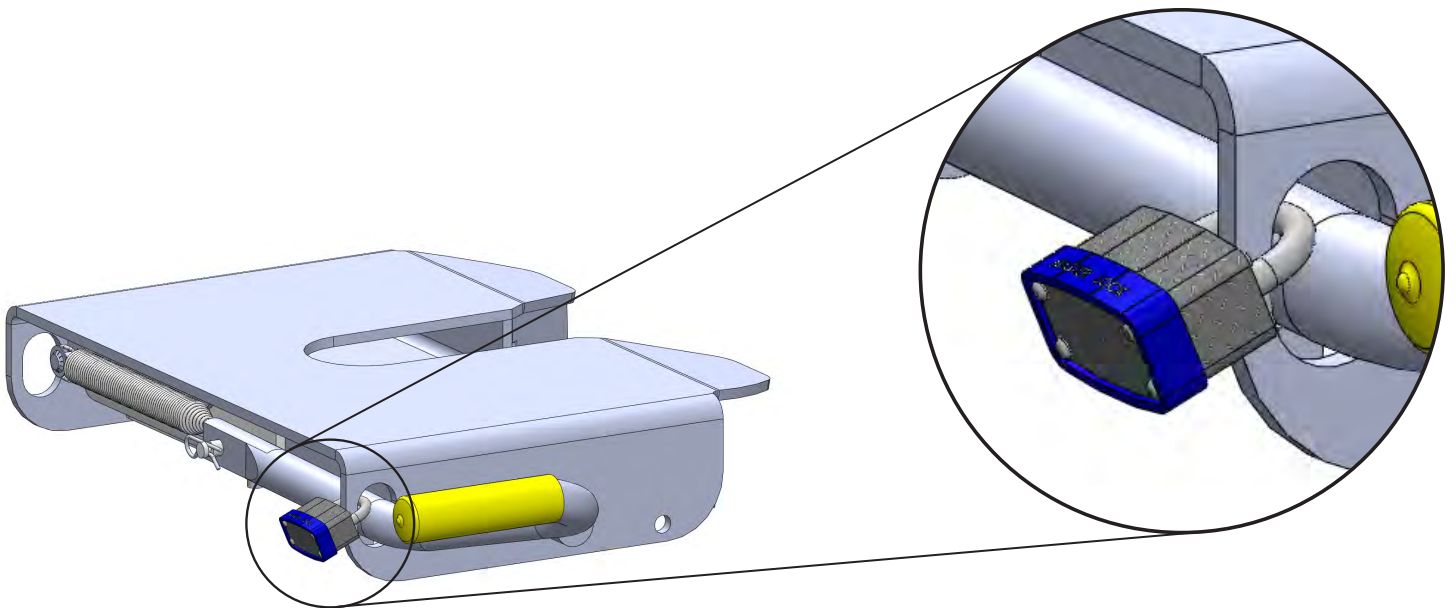
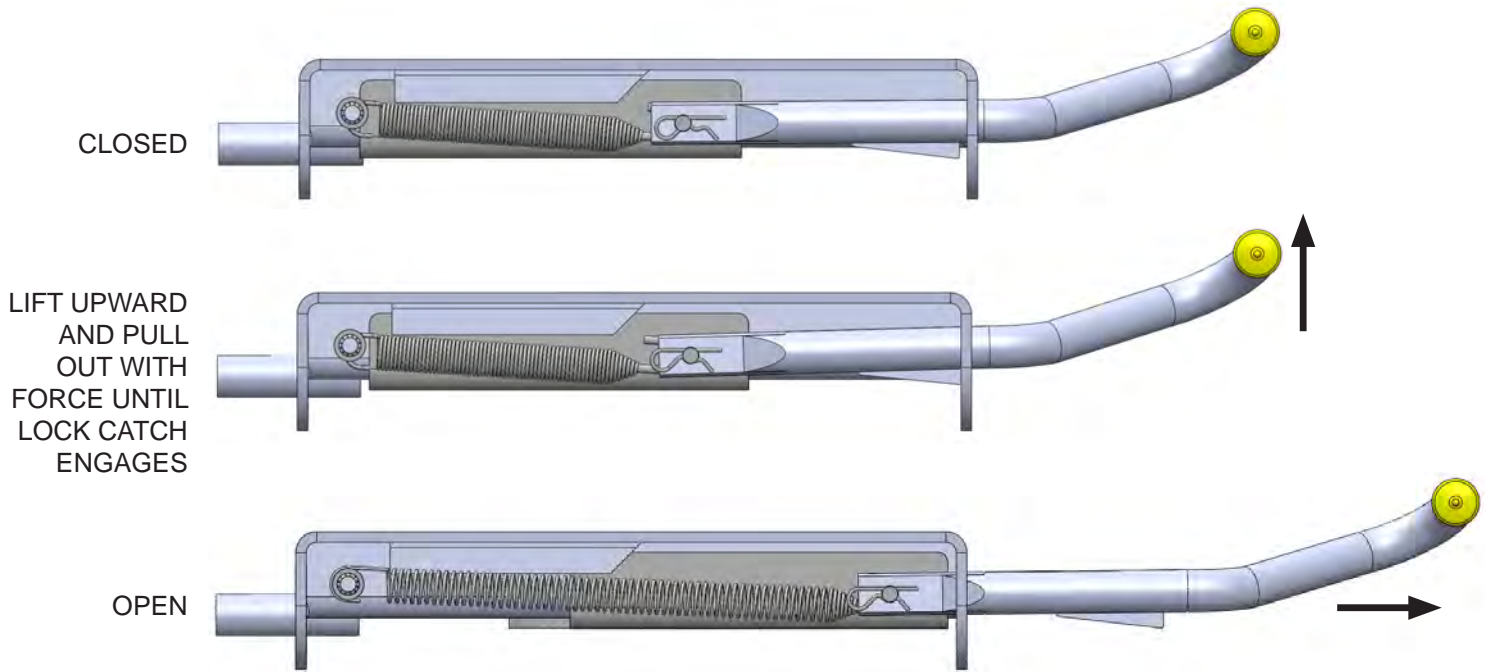

ADJUSTABLE CROSSMEMBER

The #1900, #2100, and #2200 Industry Standard Super 5ths are height adjustable models. To adjust the crossmember to one of four available positions, refer to the illustration below:

1. Remove Head Assembly. To remove Head Assembly remove Clevis Pins and Clips.
2. Remove the 1/2" bolts (#1900 or #2100 models) or 5/8" bolts (#2200 model) that attaches the Crossmember to the Side Body Bracket.
3. Position Crossmember to the correct height and reinstall bolts, washers, and nuts.
4. Torque 1/2" bolts to 75 ft. lbs. or 5/8" bolts to 151 ft. lbs.
5. Reinstall Head Assembly, Clevis Pins, and Clips.

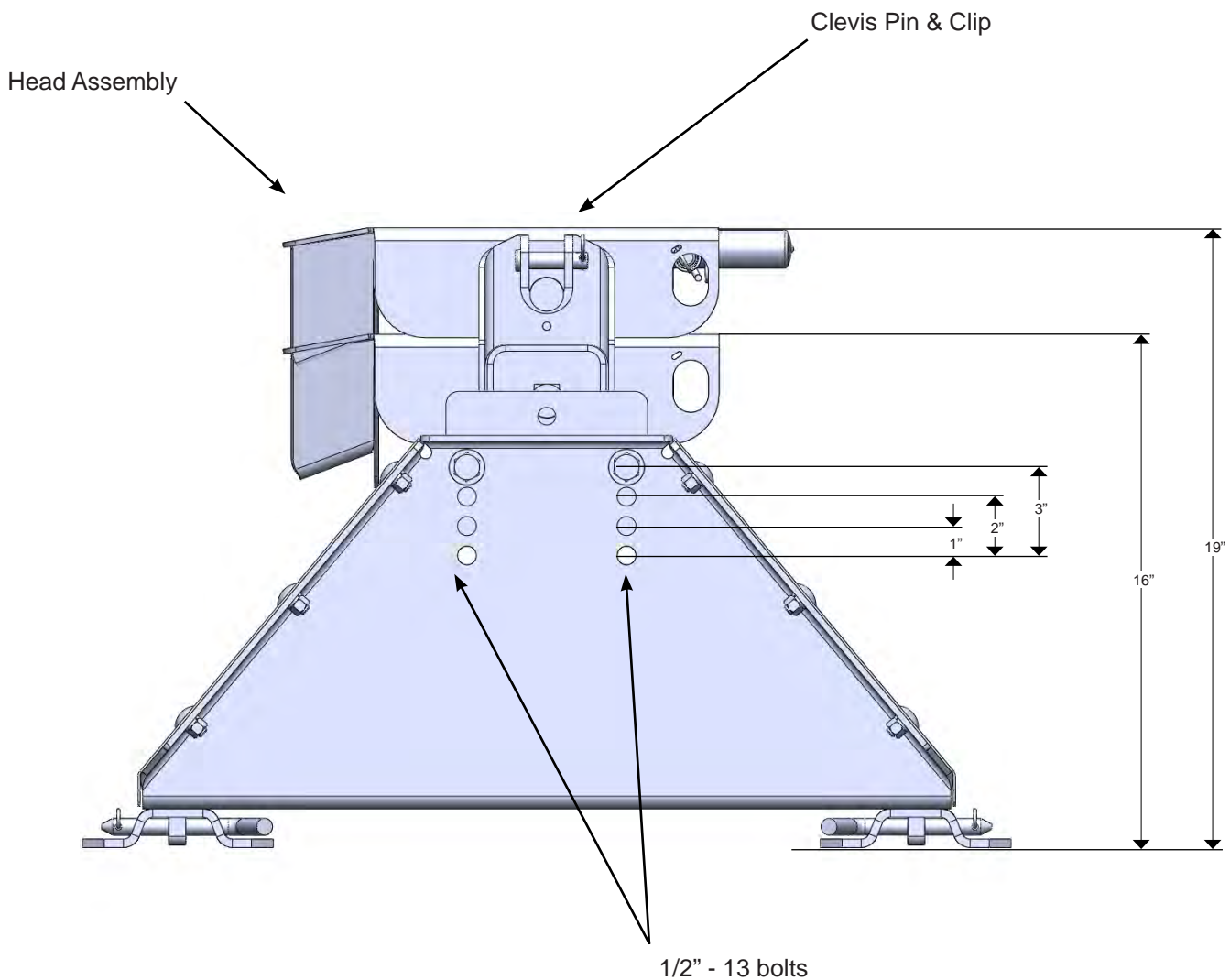

HITCHING

WARNING: Never perform any of the following actions while any part of a person is between the vehicle and trailer.

1. Align your truck with the center of the trailer. The truck should be close to parallel to the centerline of the trailer.
2. Block the trailer wheels so the trailer will not roll back.
3. Lower your tailgate and back up until there is about 6" of clearance between the Super 5th and the end of the fifth wheel plate. Raise or lower the front of the trailer so the bottom of the plate is aligned slightly above the beginning of the ramp area of the Fifth Wheel Plate. This procedure will cause the front edge of the trailer plate to "ride up" the ramp and flatten or tilt the hitch plate into a parallel position.

CAUTION: If this procedure is not followed, the king pin may bind in the plate mechanism and not lock-in properly. Following the procedure as outlined in Step 3 will ensure that you will not "high hook" the king pin in the plate. "High hooking" occurs when backing your hitch into a trailer that is set too high, resulting in the lower flange of the king pin to wedge itself against the metal edge of the lower horseshoe piece or against the Lock Jaw Assembly. Damage to the Lock Jaw Assembly may result and not allow smooth operation of the closing mechanism.

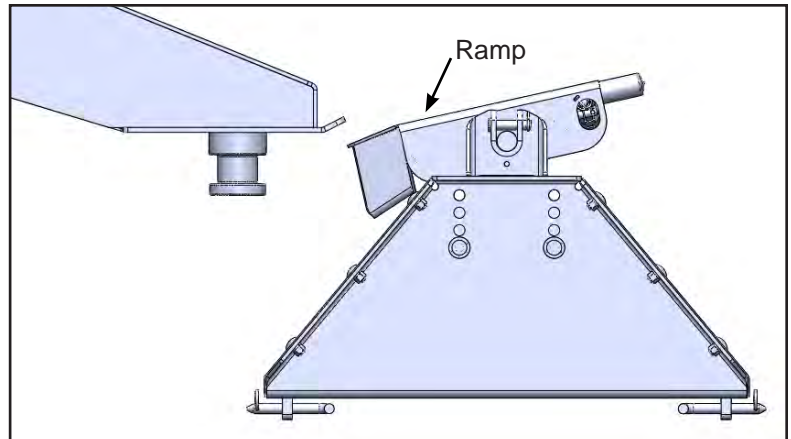

4. The Fifth Wheel Latch must be in the open position (see illustration on pgs. 6 & 7). Lift and pull out on the Release Handle to open the Lock Jaw Assembly.

CAUTION: Damage will result should you attempt to hook up with the Lock Jaw Assembly in the closed position.

5. Back up the truck in one fluid motion, so the king pin enters the center of the Fifth Wheel Plate opening.
6. Make sure the Lock Jaw Assembly is completely seated around the king pin.
7. Be sure that the Release Handle has fully returned to the closed position and proceed to "Safety Checks" on pg. 10.

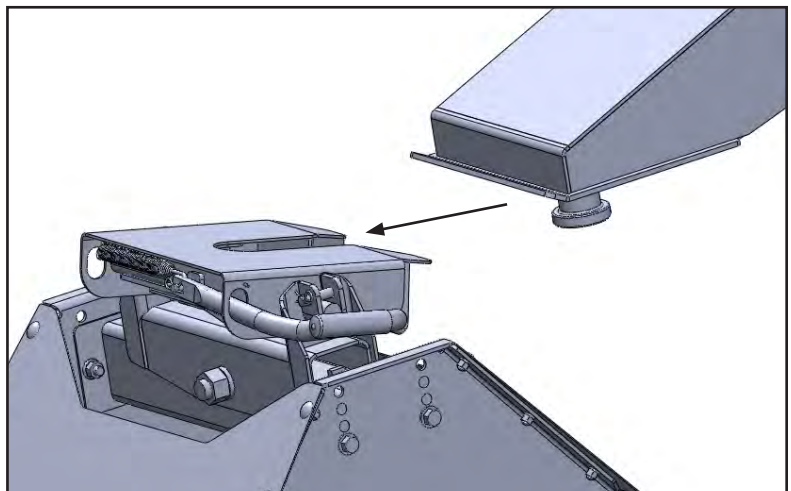

SAFETY CHECKS

1. Shine a light on the Fifth Wheel Plate Lock Jaw Assembly making sure it has closed around the king pin.
2. Pull the Release Handle towards you without lifting it up. If the Lock Jaw Assembly is completely closed the Handle Catch will prevent you from being able to pull the Release Handle open.
3. Raise the trailer jack base plates just above the ground, lock your trailer brakes, then pull the tow vehicle slowly forward putting a strain on the trailer.
4. When you are assured that the trailer is safely hooked up, raise your trailer jacks into their full retracted position.

FAILURE TO PERFORM THESE SAFETY CHECKS MAY RESULT IN DAMAGES TO TRUCK AND TRAILER.

UNHITCHING

WARNING: Never perform any of the following actions while any part of a person is between the vehicle and the trailer.

1. Once you have the trailer located and are ready to unhitch, block the trailer wheels so it will not roll back or forward. Back into the blocked trailer slightly and set the parking brake while you are still in gear. This action will relieve pressure on the lock mechanism before attempting to release the latch mechanism.
2. Lower the trailer jacks to the point of just touching the ground but do not raise the trailer at this point.
3. Open the Lock Jaw Assembly by first lifting, then pulling the Release Handle towards you (see pgs. 6 & 7).
4. Lower the trailer jacks until the bottom of the king pin box is almost free of the top of the Fifth Wheel Plate. Make certain that the bottom of the king pin is not so high that binding on the hitch Lock Catch would result.
5. After lowering the truck's tail gate, disconnect the trailer electrical cord and break-away switch cable, then pull forward.
6. As the king pin slides from the Fifth Wheel Plate, notice that the locking mechanism remains open once the king pin is removed.

CAUTION: If it should be necessary to reposition your trailer, you must follow the hitching procedures to ensure the hitch is latched before moving the trailer.

CAUTION: You may wish to keep the plate closed until you are ready to re-hitch to avoid injury or accidents to children or adults who attempt to operate the plate mechanism. **DO NOT ATTEMPT TO TRIP THE LOCK MECHANISM WITH YOUR HAND, USE A PROBE TO SIMULATE THE KING PIN.**

CHALLENGE VS. SOLUTION

CHALLENGE	SOLUTION
Cannot open the Release Handle.	You may have too much rearward pressure against the lock mechanism. Back your truck slightly to relieve pressure and continue the unhitching procedures.
Plate seems dry – Can I use a lubrication disk?	Yes you can.
Trailer overhang is hitting the truck bed rails when the trailer and truck are at sharp angles.	Raise the fifth wheel plate's height and/or lower the king pin box. There should be at least 6" between the top of the bed rails and bottom of the trailer.
The latch handle mechanism seems too stiff to operate.	Turn the plate upside-down and spray the locking mechanism with WD-40. Work the handle until it slides freely. If the problem persists, you may need to degrease and re-lube all working parts.
I need to have a professional evaluate my Super 5 th .	Contact PullRite's Customer Service Dept. Your needs will be assessed and resolved by PullRite or you will be directed to an authorized PullRite Service Center.

ILLUSTRATION — #2200 EXPLODED VIEW

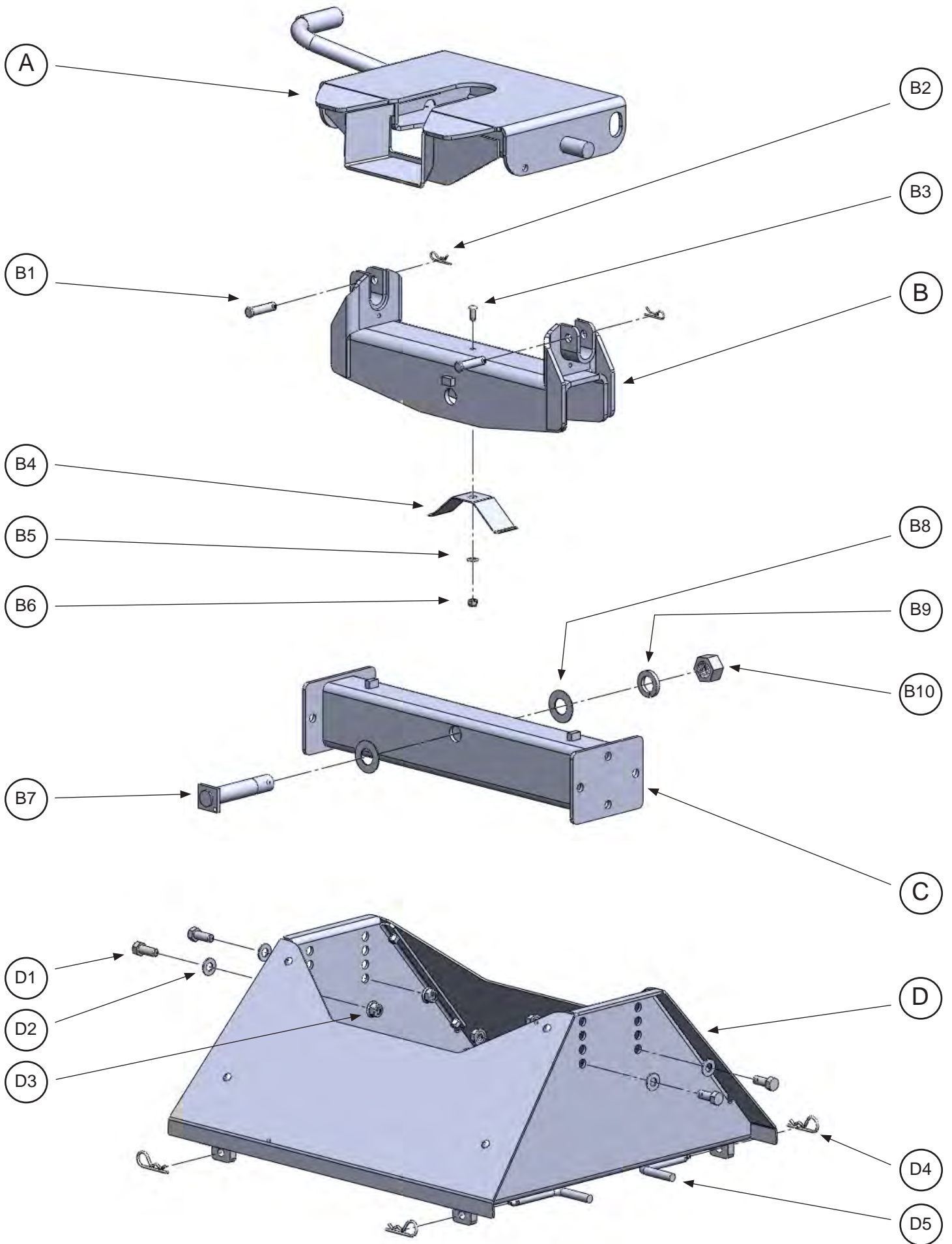

#2200 PARTS LIST

Item	Description	Part No.	Qty.	Material
A	FIFTH WHEEL PLATE	3601	1	
B	ROCKER ARM	2102	1	<i>(See assembly components below in hardware kit)</i>
C	CROSSMEMBER	2203	1	
D	HITCH BASE		1	HITCH BASE ASSEMBLY
HARDWARE KIT -- 2709				
B1	ROCKER ARM CLEVIS PIN	98410111	2	1-2" X 2" CLEVIS PIN
B2	#3 PIN CLIP	98410127	2	#3 PIN CLIP
B3	ROCKER ARM SPRING BOLT	98010242	1	5/16" - 18 X 3/4" BUTTON HEAD SOCKET CAP SCREW
B4	ROCKER ARM SPRING	2103040	1	16 GA SPRING STEEL
B5	ROCKER ARM SPRING FLAT WASHER	98250160	1	5/16" ZINC FLAT WASHER
B6	ROCKER ARM NUT	98150202	1	5/16" - 18 NYLOCK NUT
B7	ROCKER ARM PIVOT BOLT	210501	1	ROCKER ARM PIVOT BOLT ASSEMBLY
B8	ROCKER ARM PLASTIC WASHER	41030405	2	1" PLASTIC WASHER
B9	ROCKER ARM LOCK WASHER	98200115	1	1" SPLIT LOCK WASHER
B10	ROCKER ARM NUT	98150120	1	1" HHCS GRD 5
D1	BASE BOLT	98010231	4	5/8"-11 X 1-1/2" HHCS GRD 5
D2	BASE FLAT WASHER	98250116	4	5/8" ZINC FLAT WASHER
D3	BASE FLANGE NUT	98150200	4	5/8"-11 ZINC SERRATED FLANGE NUT
D4	#9 PIN CLIP	98410143	4	#9 COTTER PIN
D5	HITCH PIN	27090001	4	1/2" ROUND
BASE RAIL KIT				
<i>PULLRITE INDUSTRY STANDARD BASE RAILS ARE SOLD SEPARATELY.</i>				

ILLUSTRATION — #2100 EXPLODED VIEW

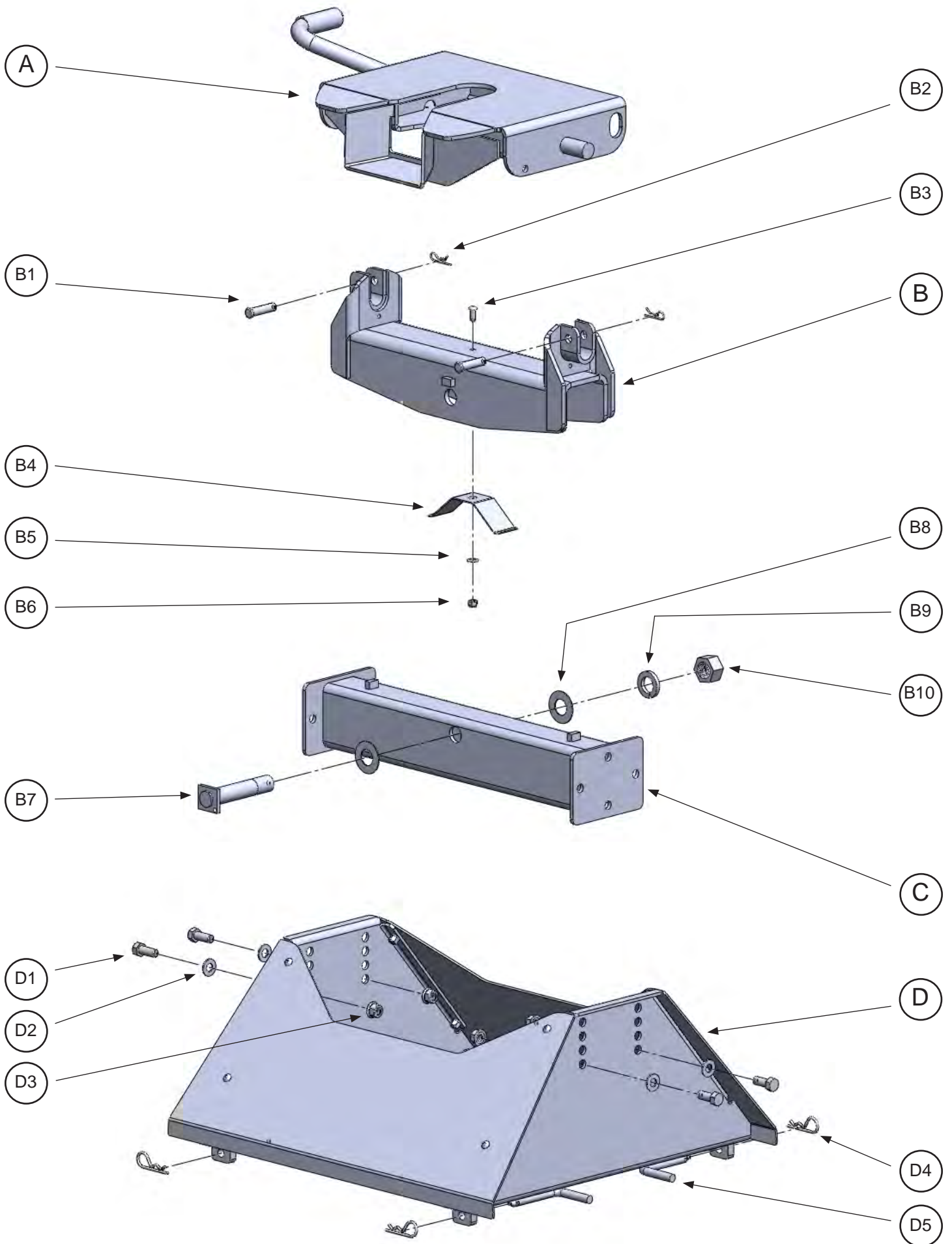

#2100 PARTS LIST

Item	Description	Part No.	Qty.	Material
A	FIFTH WHEEL PLATE	3601	1	
B	ROCKER ARM	2102	1	<i>(See assembly components below in hardware kit)</i>
C	CROSSMEMBER	2103	1	
D	HITCH BASE		1	HITCH BASE ASSEMBLY
HARDWARE KIT -- 2709				
B1	ROCKER ARM CLEVIS PIN	98410111	2	1-2" X 2" CLEVIS PIN
B2	#3 PIN CLIP	98410127	2	#3 PIN CLIP
B3	ROCKER ARM SPRING BOLT	98010242	1	5/16" - 18 X 3/4" BUTTON HEAD SOCKET CAP SCREW
B4	ROCKER ARM SPRING	2103040	1	16 GA SPRING STEEL
B5	ROCKER ARM SPRING FLAT WASHER	98250160	1	5/16" ZINC FLAT WASHER
B6	ROCKER ARM NUT	98150202	1	5/16" - 18 NYLOCK NUT
B7	ROCKER ARM PIVOT BOLT	210501	1	ROCKER ARM PIVOT BOLT ASSEMBLY
B8	ROCKER ARM PLASTIC WASHER	21030104	2	1" PLASTIC WASHER
B9	ROCKER ARM LOCK WASHER	98200115	1	1" SPLIT LOCK WASHER
B10	ROCKER ARM NUT	98150120	1	1" HHCS GRD 5
D1	BASE BOLT	98010177	4	1/2" - 13 X 1-1/4" HHCS GRD 5
D2	BASE FLAT WASHER	98250147	4	1/2" SAE ZINC FLAT WASHER
D3	BASE FLANGE NUT	98150201	4	1/2"-13 ZINC SERRATED FLANGE NUT
D4	#9 PIN CLIP	98410143	4	#9 COTTER PIN
D5	HITCH PIN	27090001	4	1/2" ROUND
BASE RAIL KIT				
<i>PULLRITE INDUSTRY STANDARD BASE RAILS ARE SOLD SEPARATELY.</i>				

ILLUSTRATION — #1900 EXPLODED VIEW

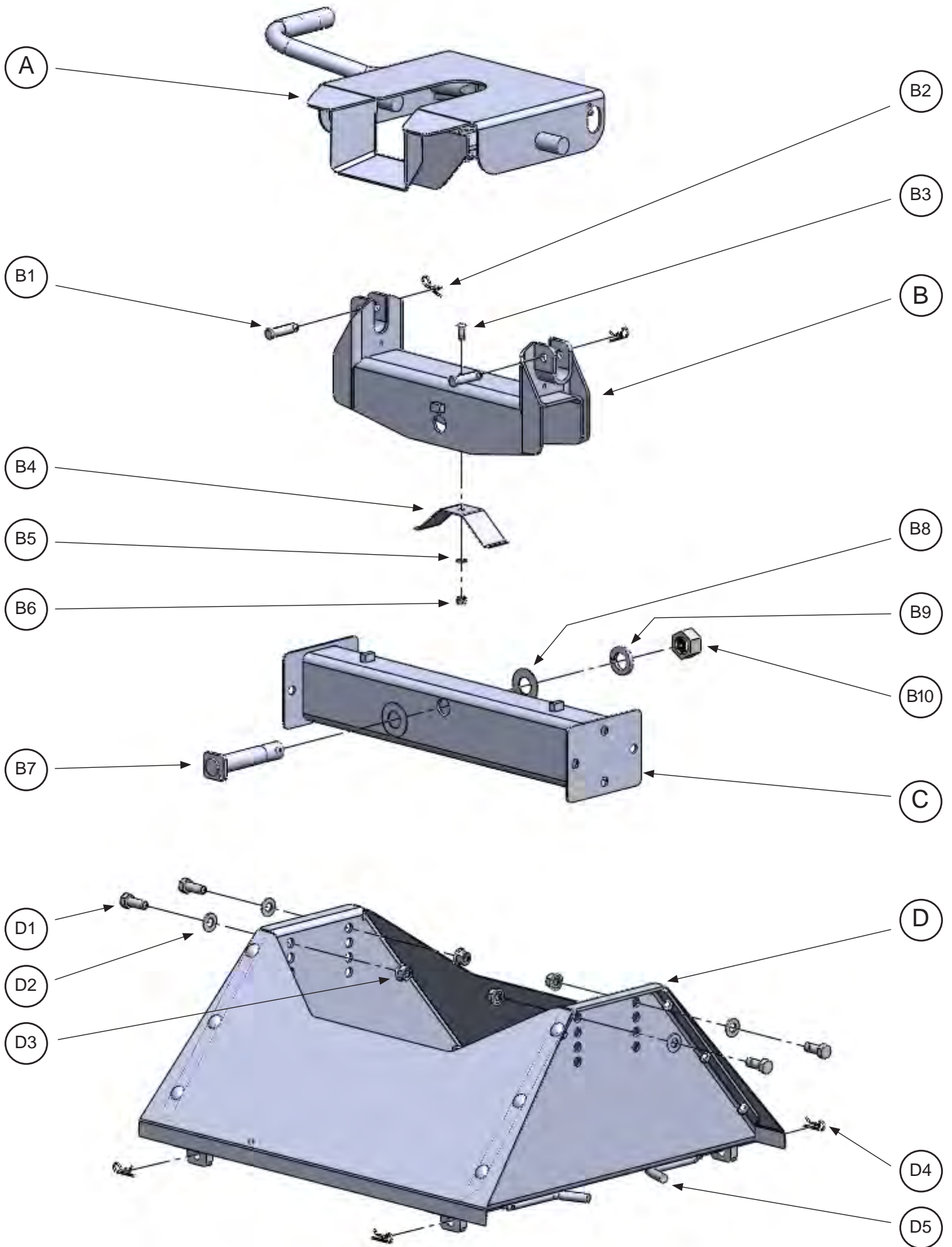

#1900 PARTS LIST

Item	Description	Part No.	Qty.	Material
A	FIFTH WHEEL PLATE	1901	1	
B	ROCKER ARM	1902	1	<i>(See assembly components below in hardware kit)</i>
C	CROSSMEMBER	1903	1	
D	HITCH BASE		1	HITCH BASE ASSEMBLY
HARDWARE KIT -- 2709				
B1	ROCKER ARM CLEVIS PIN	98410111	2	1-2" X 2" CLEVIS PIN
B2	#3 PIN CLIP	98410127	2	#3 PIN CLIP
B3	ROCKER ARM SPRING BOLT	98010242	1	5/16" - 18 X 3/4" BUTTON HEAD SOCKET CAP SCREW
B4	ROCKER ARM SPRING	2103040	1	16 GA SPRING STEEL
B5	ROCKER ARM SPRING FLAT WASHER	98250160	1	5/16" ZINC FLAT WASHER
B6	ROCKER ARM NUT	98150202	1	5/16" - 18 NYLOCK NUT
B7	ROCKER ARM PIVOT BOLT	210501	1	ROCKER ARM PIVOT BOLT ASSEMBLY
B8	ROCKER ARM PLASTIC WASHER	21030104	2	1" PLASTIC WASHER
B9	ROCKER ARM LOCK WASHER	98200115	1	1" SPLIT LOCK WASHER
B10	ROCKER ARM NUT	98150120	1	1" HHCS GRD 5
D1	BASE BOLT	98010177	4	1/2" - 13 X 1-1/4" HHCS GRD 5
D2	BASE FLAT WASHER	98250147	4	1/2" SAE ZINC FLAT WASHER
D3	BASE FLANGE NUT	98150201	4	1/2"-13 ZINC SERRATED FLANGE NUT
D4	#9 PIN CLIP	98410143	4	#9 COTTER PIN
D5	HITCH PIN	27090001	4	1/2" ROUND
BASE RAIL KIT				
<i>PULLRITE INDUSTRY STANDARD BASE RAILS ARE SOLD SEPARATELY.</i>				

5 YEAR LIMITED WARRANTY

PULLIAM ENTERPRISES, INC. hereinafter referred to as "PULLIAM", warrants to the first retail owner only, this PullRite towing system to be free from defects in materials and workmanship for a period of five (5) years or 31,068 miles (50,000 km) after the installation on purchaser's vehicle, whichever occurs first.

To validate this warranty, the first retail owner must mail the provided warranty card to PULLIAM, within ten (10) days after installation of said towing system on his vehicle.

The owner is responsible for all normal and preventative maintenance described in the Owner's Manual.

If any defect occurs which the owner believes is covered by this warranty within said five (5) year period, the owner shall contact PULLIAM immediately, either in writing or by telephone call, Attention Customer Service Department. The owner will be instructed to return the hitch at his expense either to an authorized PullRite dealer or to PULLIAM to repair or replace any parts necessary to correct defects in material or workmanship.

Repair or replacement shall be at the sole option of PULLIAM and shall be completed by or on behalf of PULLIAM free of charge for materials and labor.

This warranty gives you specific legal rights, and you may also have other rights which vary from state to state.

THIS WARRANTY SPECIFICALLY *EXCLUDES* EACH OF THE FOLLOWING:

1. Defects in the product resulting from misuse, neglect, accident, loading beyond the vehicle's capacity, failure to comply with instructions contained in the Owner's Manual or unauthorized repairs, replacements, alterations or modifications. "Unauthorized repair, replacements, alterations" are those made without PULLIAM'S prior knowledge and consent.
2. Any incidental or consequential damage including, but not limited to, loss of use of the vehicle, towing charges, vehicle rental, loss of time, inconvenience, travel, gasoline, lodging and telephone expenses, loss of revenue and damages on account of personal injury and property damage. (Some states do not allow the exclusion or limitation of incidental or consequential damages, so these limitations may not apply to you).
3. Repairs or replacements of defects in any PullRite towing system, or part thereof, installed on any vehicle which has been rented, leased or used for any commercial purpose.
4. Any representation, warranty of undertaking made by any dealer or third party beyond the scope of the warranty herein expressed.
5. Any problem resulting in normal deterioration due to wear or exposure.

TO THE EXTENT PERMITTED BY LAW, IMPLIED WARRANTIES OF MERCHANTABILITY AND FITNESS FOR A PARTICULAR PURPOSE ARE LIMITED IN DURATION TO FIVE YEARS FROM THE DATE OF INSTALLATION ON THE FIRST OWNER'S VEHICLE. (SOME STATES, HOWEVER, DO NOT ALLOW LIMITATIONS AS TO DURATION OF IMPLIED WARRANTY, SO THOSE LIMITATIONS MAY NOT APPLY TO YOU)



Product Warranty Registration

As an owner of a PullRite product, you must register your product to be considered for warranty coverage. See Owners Manual for further details.

Name: _____

Address: _____

City: _____ State: _____ Zip: _____

Email Address: _____

Phone (optional): _____

Purchase Price: _____ Date of Purchase: _____

Dealer's Name: _____

Dealer's Address: _____

Dealer's City: _____ Dealer's State: _____ Dealer's Zip: _____

Dealer's Phone: _____

Model Purchased: _____

Vehicle Make: _____ Vehicle Model: _____ Vehicle Year: _____

Vehicle Year: _____ Vehicle Cab Style: _____ Vehicle Bed Length: _____

Did you receive an Owners Manual from the Dealer? Yes / No

What influenced you to buy your hitch? _____

Comments: