

INSTALLATION INSTRUCTIONS

Adjustable Electric Fan Controller

KIT CONTENTS

Q'TY	DESCRIPTION	Q'TY	DESCRIPTION
1	Fan Control Module	1	Yellow 5/16" Ring Terminal
1	30/40 Amp Relay	1	Blue 5/16" Ring Terminal
1	Wire Harness with Probe	1	Blue #10 Ring Terminal
1	3' 12Ga. Red Wire	1	Blue Wire Tap Connector
2	#10 Sheet Metal Screws	1	Red Butt Connector
2	Blue Butt Connectors	4	4" Wire Ties

SELECTED MODEL

3/8" NPT Thread-in Probe

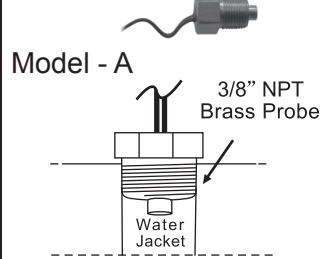

Push-in Radiator Probe

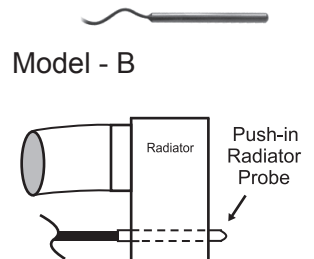

The adjustable fan thermostat allows the user to custom tailors the turn-on temperature. Factory preset at 160 degrees, adjustment range is **150-240 degrees**.

Note: This unit utilizes a GROUND switching. It will activate the Electric Fan(s) at one set temperature. It is not designed to have two activating temperature set points. Before starting installation, read the instructions completely and disconnect the battery.

MAXIMUM DRAW OF 25 CONTINUOUS AMPS.

FAN CONTROL MODULE INSTALLATION

The fan control module must be mounted in a cool, dry location, away from hot components. The temperature probe wires are 18" long but can be lengthened to allow mounting the control box further from the radiator. When lengthening probe wires use good quality connections and wire.

1. Using mounting feet on fan control module as a guide, mark and drill two 5/32" holes.
2. Using the two #10 metal screws provided, top mount the control module.

TEMPERATURE PROBE INSTALLATION

Model-A: The temperature probe must be inserted into a 3/8" NPT port on the engine or radiator. Often the intake manifold or cylinder heads have an available port.

Note: Thread sealant must be used when installing the probe.

Model-B: The temperature probe must be inserted into the radiator core between the fins. The best location is close to the water inlet near the radiator tank. The probe should fit tightly in the radiator fins and should not extend past radiator core more than 1/4".

Note: Do not use sharp objects to install temperature probe. Do not install the probe in radiator water or radiator hoses. Water will damage temperature probe.

The probe wires can be lengthened if necessary

WIRING

Red (Loose wire): Positive (+) battery to positive (+) Fan lead.

Using the Yellow Ring Terminal provided, attach one end of the red loose wire to the vehicle positive (+) terminal on the battery.

Using the Blue Butt Connector provided, attach the other end of the loose Red wire to the positive (+) lead on the electric fan.

Red (fused harness wire): To negative (-) electric fan lead.

Using the Blue Butt Connector provided, attach the red wire to the negative (-) lead on the electric fan. If you are running two small electric fans, the total continuous amperage **cannot exceed 25 amps**. The Red wire can be connected in paralleled to both negative (-) fan leads.

Black Wire: Chassis Ground (-).

Using the Blue Ring Terminal provided, attach the black wire to a good chassis ground.

Yellow Wire: Switched Ignition source.

Using the Red Butt Connector provided, attach the yellow wire to a positive (+) switching ignition source.

Note: If the yellow wire is connected to a constant power source (battery), the electric fan will run after the vehicle is shut off and could run down the battery.

Green Wire: Override Circuit (Optional)

The green wire is designed to work in two different configurations. When used, this will allow the fan(s) to be turned on regardless of the thermostat as it simply overrides all other functions. If you choose not to use this option cut any exposed copper and tape or shrink-wrap the end of the wire.

1. AC Override – Using the blue wire tap provided, attach the green wire to the positive lead on the air conditioning compressor.
2. Manual Switch Override – Attach the green wire to the manual switch. Positive (+) needs to be switched.

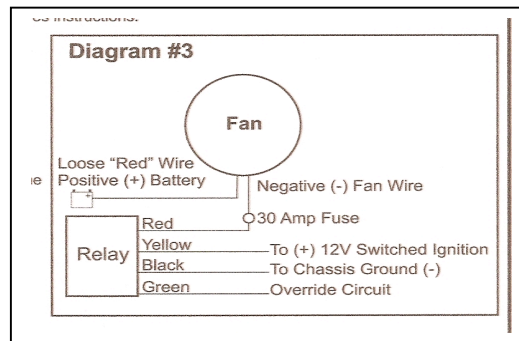

TEMPERATURE ADJUSTMENT

DO NOT ADJUST TEMPERATURE UNTIL AFTER VEHICLE IS RUNNING!

1. Remove the Rubber Adjustment Plug on the Control Module.
2. Turn adjustment screw counter clockwise to lower fan turn-on temperature.
3. Turn adjustment screw clockwise to raise fan turn-on temperature.
4. Adjustment range is $\frac{3}{4}$ of a turn. **Do not force screw past stop, or all warranty is void!** Insure vehicle is up to operating temperature before adjusting.
5. Replace the Rubber Adjustment Plug.

