



# INSTALLATION INSTRUCTIONS CARGO CARRIER

Product No.  
**63153**  
**63155**

**WARNING:** With a **5000 lb.** rated receiver the cargo carrier can carry a **maximum 500 lb.** load, with a **3500 lb.** rated receiver it can carry a **maximum 300 lb.** load. **DO NOT EXCEED** lower of vehicle mfg's or hitch mfg's maximum tongue weight rating.

**WARNING:** Not for transport of people, animals, or flammable liquids.

**WARNING:** If the load or cargo carrier blocks or impairs visibility of the taillights or turn signals, the optional light kit must be used.

**WARNING:** If the cargo carrier or the contents being transported is in line with the exhaust outlet, an exhaust tip must be used to redirect the exhaust flow away from the cargo platform or contents.

**WARNING:** Do not lubricate threads. Bolt failure may occur due to over tightening.

**WARNING:** Securely fasten load to cargo carrier. Attach straps and/or tie down hooks to the tubular frame of cargo carrier.

**WARNING:** Do not attach tie down straps or hooks to the mesh cargo floor. Do not over-tighten ratcheting straps, damage to cargo carrier may result from over-tightening.

**WARNING:** Do not carry any loads wider than your vehicle.

**WARNING:** Do not drill (except where specified for license plate mounting) or weld to this product.

**WARNING:** Relocate license plate if blocked by load or cargo carrier.

## TOOLS REQUIRED

13MM WRENCH  
19MM WRENCH  
TORQUE WRENCH

**FIG. 1**

M12 X 80mm LG. CL9.8 (63153)  
M12 X 55mm LG. CL9.8 (63155)  
LOCKNUT  
(3) PLACES

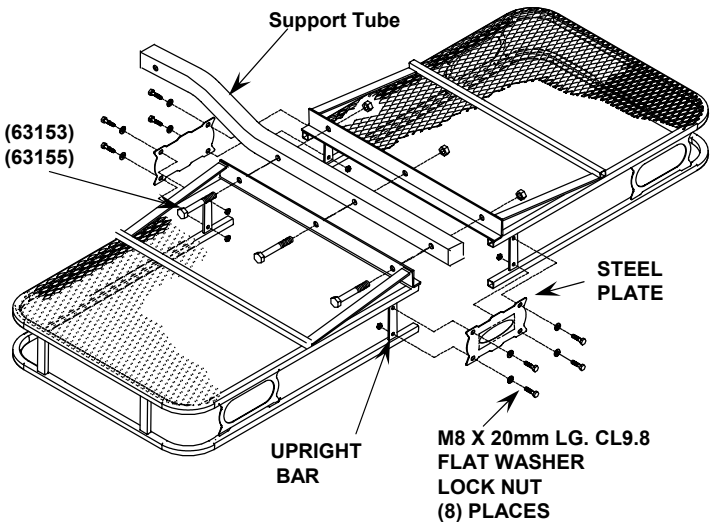

**FIG. 2**

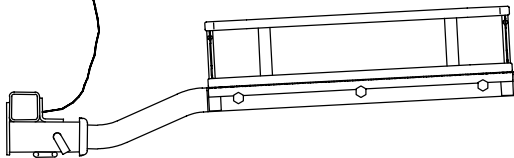

**SHANK MUST BE USED IN THE RISE POSITION ONLY**

## ASSEMBLE TRAY

- Place tray on a flat surface with the cargo mesh floor facing up as shown. Slide the two halves together and attach the two steel plates to the upright bars with the logo label to the outside as shown using the M8 hex bolts as shown in Figure 1. (Both Sides) **IMPORTANT:** Leave these bolts loose at this time. It will be easier to attach the support tube to the cargo basket the next step.
- Place the support tube in between the two support rails on the bottom of the tray. Attach the tube to the bottom of the tray using the M12 X 55mm long (63155) or M12 X 80mm long (63153) hex bolts as shown in Figure 1.
- Tighten all bolts. Torque M12 CL9.8 bolts to 75 ft•lb. Torque M8 CL9.8 bolts to 25 ft•lb.

**LOADING:** Load the Cargo Carrier so that most of the weight is in the center of the platform. **Maximum load rating is 500 lb. with a 5,000 lb. weight carrying hitch, and 300 lb. with a 3,500 lb. weight carrying hitch.**

**FIG. 3**

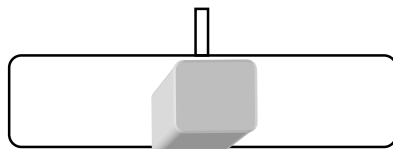

**CORRECT**

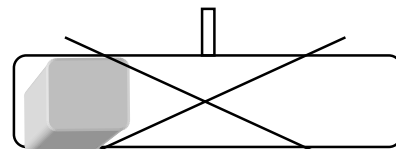

**INCORRECT**

**IMPORTANT NOTE:** If the Cargo Carrier or cargo blocks the license plate, you can mount the license plate directly to the back of the Cargo Carrier. Use the license plate as a template to mark two holes to drill. Diameter of the holes will depend on the screws (not included) you are using, but should not exceed 1/4" diameter (6.35mm).