

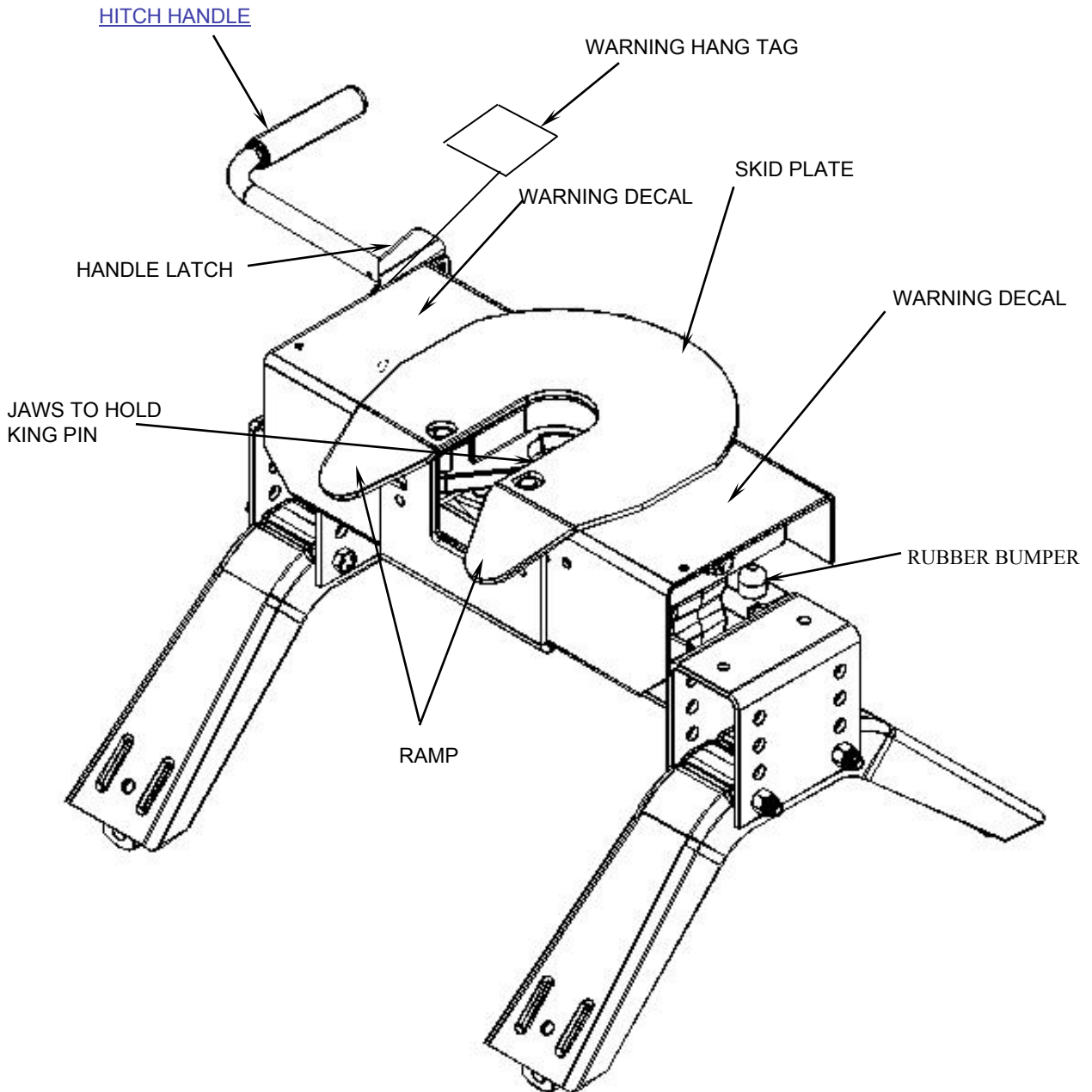
INSTRUCTION MANUAL PRO SERIES 20,000

DEALER/INSTALLER:

- (1) Provide this Manual to end user.
- (2) Physically demonstrate hitching and unhitching procedures in this Manual to end user.
- (3) Have end user demonstrate that he/she understands procedures.

END USER:

- (1) Read and follow this Manual every time you use the hitch.
- (2) Save this Manual and Hitch Warning Hang Tag for future reference.
- (3) Pass on copies of Manual and Hitch Warning Hang Tag to any other user or owner of hitch.
- (4) Never remove hitch warning decals as shown on the cover of this manual.



GUIDELINES FOR MATCHING HITCH TRUCK AND TRAILER

⚠ WARNING:

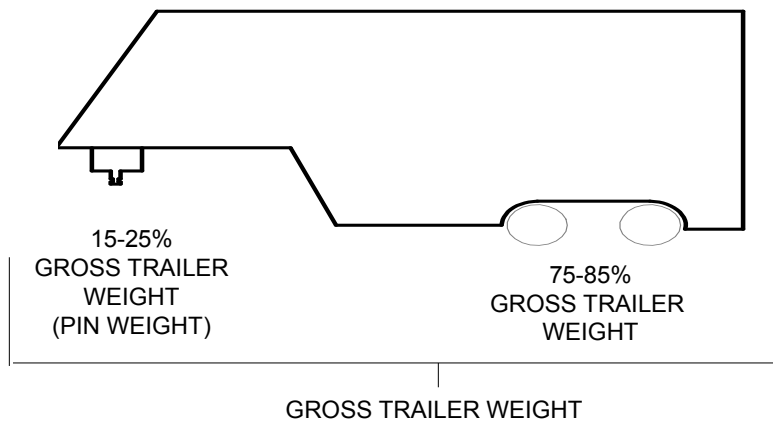
- Trailer and its contents together must not exceed truck, hitch and/or trailer tow ratings.
- Towing vehicle must have a manufacturer's rated towing capacity equal to or greater than the gross trailer weight (dry weight of the trailer plus payload of the trailer). (See Fig. 1)
- Gross weight of trailer must not exceed 20,000 pounds.
- King pin weight must not exceed 5000 pounds (See Fig. 2). If in doubt have king pin weight measured by qualified facility.

Fig. 1



1. This hitch is designed for use with recreational fifth wheel trailers only. Hitch applications other than recreational fifth wheel trailers must be approved in writing by Towing Product's Engineering Department.
2. Use only a SAE 2-inch kingpin with this Fifth Wheel Hitch.
3. Approximately 15%-25% of trailer weight should be on hitch (Pin Weight). See Fig. 2.

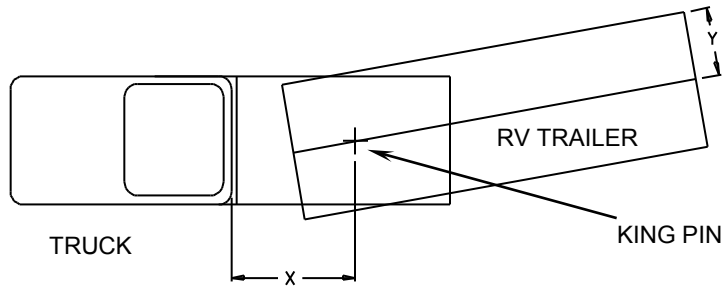
Fig. 2



4. Trucks come in many different configurations. This hitch is designed for use in light trucks such as the Ford F-Series, the Chevy Silverado and the Dodge Ram. This hitch is recommended for use with long bed (8ft) light trucks for the best combination in truck - trailer turning clearance.

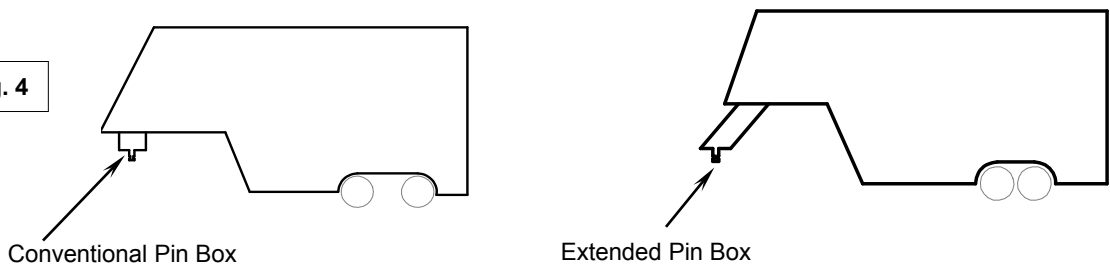
Rule of thumb: The distance from the back of the truck cab to the center of the rear truck axle ("X" in Fig. 3), should be approximately 4 inches greater than one-half the trailer width ("Y" in Fig.3) unless using a Sidewinder or Revolution Pin Box.

Fig. 3



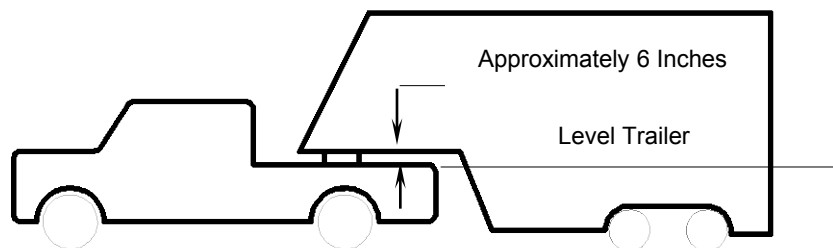
5. If a short bed pickup (less than 8 ft. but longer than 6 ft.) is to be used for towing, Cequent Performance Products recommends the trailer be equipped with an extended pin box to help gain additional truck - trailer turning clearance (See trailer manufacturer for options) (See Fig. 4). Or it also may be helpful to add a **30048 or 50008 or 30092 slider with an extended pinbox** for increased turning clearance for low speed, non-highway maneuvering. The use of a Reese Sidewinder would also give additional turning clearance.

Fig. 4



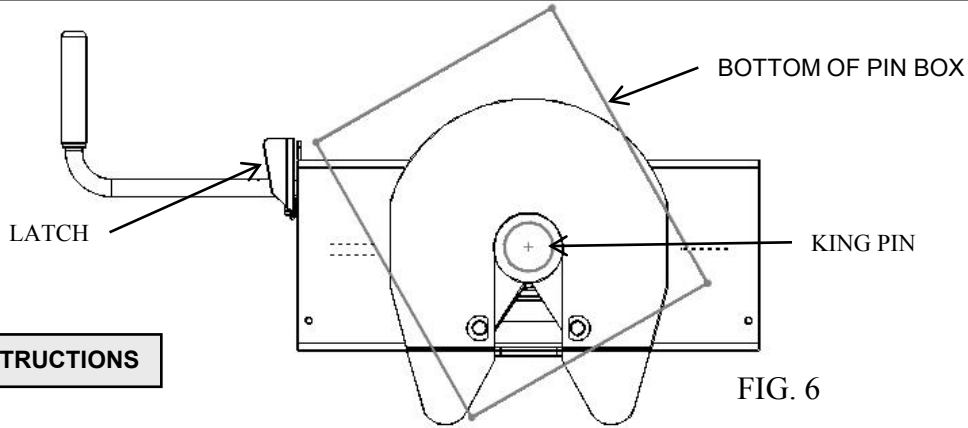
6. The height of the hitch and the pin box should be adjusted so the trailer is approximately level as it is towed. Allow approximately 6 inches clearance between the top of the pickup walls and the underside of the front of the trailer for pitch and roll of the trailer. (See Fig. 5). Allow more clearance between pickup walls and trailer for off road use.

Fig. 5



⚠ WARNING:

Do Not use this hitch for towing a trailer with a pin box that could come into contact with or interfere with the latch for the hitch handle when turning! (See Fig. 6) If the pin box contacts the hitch handle or its latch when turning, the trailer may become unhitched.

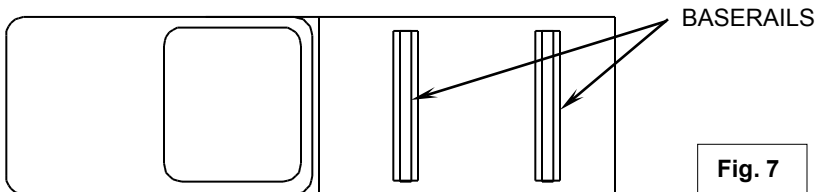


ASSEMBLY INSTRUCTIONS

⚠ WARNING:

- Connection for trailer wiring should be in the side of the truck bed between the driver's seat and the wheel well for the back truck axle
- Installation of connection rearward of the wheel well may result in user placing body between truck and trailer. **WHENEVER POSSIBLE, AVOID PUTTING BODY UNDER TRAILER OR BETWEEN TRUCK AND TRAILER!**
- If you need to place any part of your body under trailer or between truck and trailer:
 - All trailer tires **MUST** be blocked in front and behind each tire **AND**
 - Trailer landing gear **MUST** be resting on firm ground **AND**
 - Truck **MUST** be stationary, in park, with emergency brake on!

1. Reference Fig. 19 on back page. Numbers in parentheses refer to parts in Fig. 19.
2. 5th Wheel Kit is contained in multiple cartons. Unpack and become familiar with parts on parts list.
3. Place two base rails (28) across bed of truck (See Fig. 7). Select one leg (22) and place tabs through the middle set of rectangular slots in the base rails. Slip long pull pins (25) through holes in base rails from the outside in as shown so the cotter pins are on the inside of the base rails. Repeat for other leg. Secure pull pins with spring retaining pins (26).



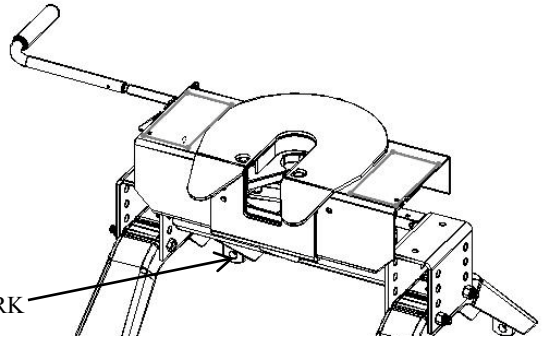
4. Select head support (17) and install on leg aligning holes for hitch height desired. (Lowest position 13" highest 17"). Install four 1/2-13 x 4.5" Hex bolts (21), (with heads toward inside as shown) and lock nuts (20).
5. Torque 1/2" nuts to 75 lb. ft.
6. Install base rails and mounting brackets as described in their instructions.

⚠ WARNING

Base rails must be bolted through the floor of the pickup to the brackets that attach to the truck frame. **DO NOT INSTALL BY FASTENING TO THE FLOOR OF THE PICKUP BOX ONLY.** The floor alone is not strong enough to carry the loads imposed by the trailer.

7. Install outer tubular handle (2) over solid inner handle (4) and pin together with cotter pin. Bend cotter pin to hold in place. Check that latch bolt (8) is snug. Do not over tighten latch (3) must be able to move with firm hand effort. Check to see that all retainer rings are in place.

8. Grease the pivot pin before the first trip and once a year thereafter.



BEFORE EACH TRIP:

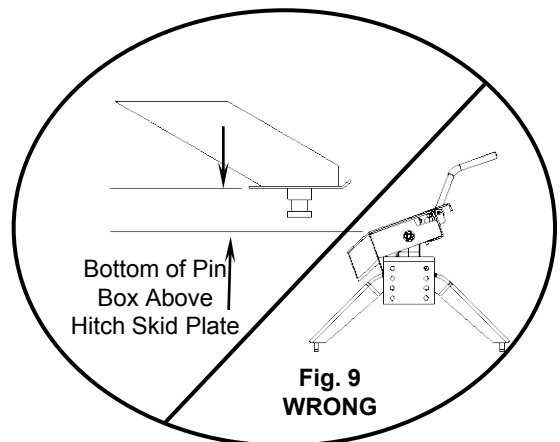
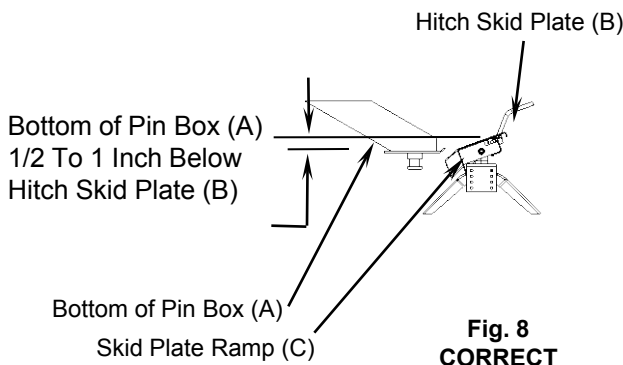
1. Lubricate skid plate surface of the hitch (see figure on cover of Manual) with automotive type chassis grease or use a plastic lube plate to provide a lubricated surface. Grease the 1-1/2" diameter pivot pin with the grease zerk provided. Use engine oil to lubricate pivot points of moving parts within the hitch.
2. Plastic lube plates can be used to avoid messy grease. The plastic lube plate must not exceed 3/16 of an inch in thickness to ensure hitch will operate properly. Lube plates must be 10 inches in diameter or larger to properly distribute king pin weight.
3. Before each trip or maneuver, operate the handle and check that the jaws open and close freely.
4. See that all hitch pull pins (# 25 on Fig. 20) are in place and the spring retaining pins (#26 on Fig. 20) are installed.

HITCHING PROCEDURE:

IMPORTANT: YOU ARE RESPONSIBLE FOR SAFE HITCHING AND UNHITCHING OPERATIONS. DO NOT RELY ON OTHERS TO PERFORM YOUR DUTIES. YOU MUST PERSONALLY MAKE SURE THE FOLLOWING STEPS ARE PERFORMED IN THE FOLLOWING ORDER!

⚠ WARNING:
FAILURE TO FOLLOW THESE INSTRUCTIONS MAY RESULT IN DEATH OR SERIOUS INJURY.

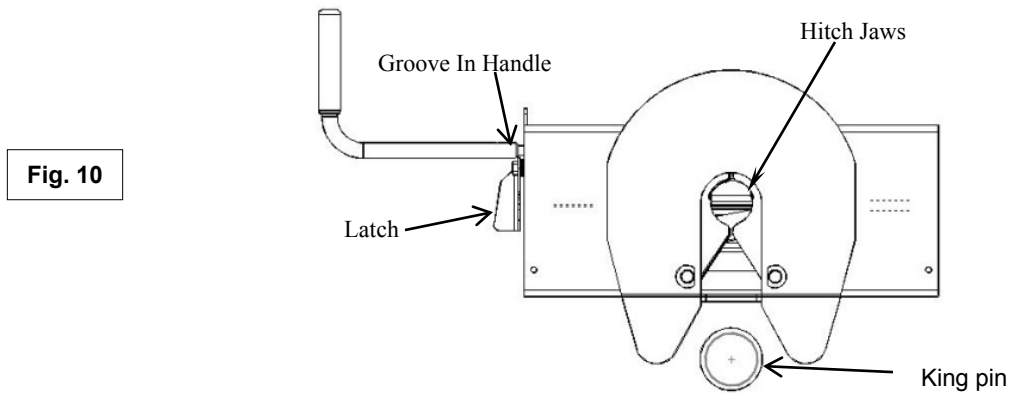
1. Place blocks (sometimes called "chocks") firmly against front and rear of each trailer wheel to prevent any possible forward or rearward motion. DO NOT REMOVE BLOCKS UNTIL EACH OF THE FOLLOWING STEPS AND THE PULL TEST HAVE BEEN COMPLETED. Lower tailgate if necessary.
2. Using trailer jacks, adjust trailer height following the directions in the trailer manual so that bottom of trailer pin box ("A" in Fig. 8) is 1/2 to 1 inch below skid plate (See "B" in Fig. 8). During the hitching maneuver, the bottom of the trailer pin box should come in contact with skid plate ramp ("C" in Fig. 8).



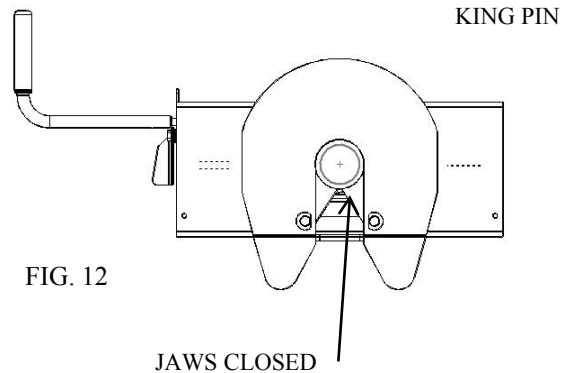
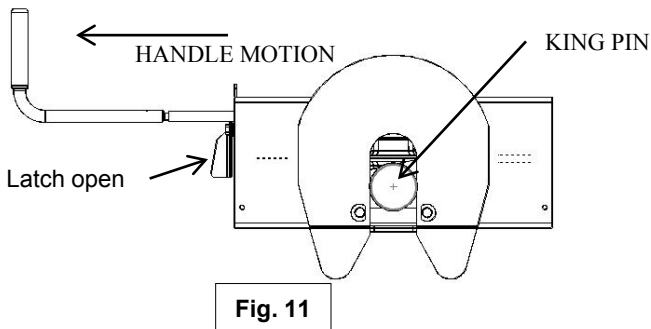
⚠ WARNING:

Failure to follow this instruction may result in king pin being too high and coming to rest on top of closed jaws or not completely inside jaws. (See Fig. 9). This could result in trailer separating from hitch. Trailer separation may result in death or serious injury if anyone is under the trailer or between truck and trailer when separation occurs.

3. Rotate latch (see Fig. 10) toward trailer and free of groove in handle. NOTE: Hitch jaws will not open and proper hitching cannot occur if latch is in handle groove.



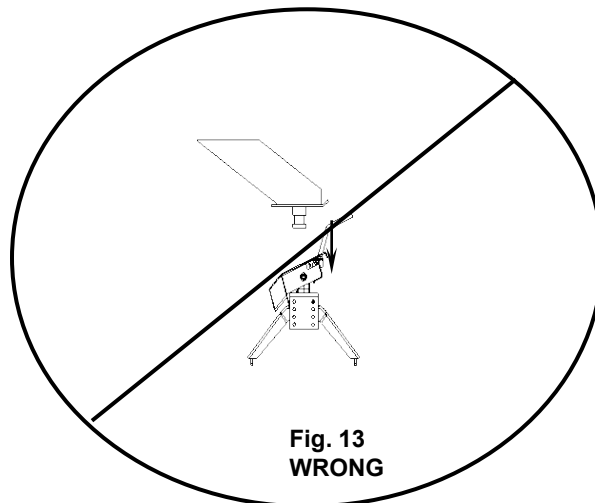
4. With handle in the closed position (See Fig. 10), back truck slowly into trailer. As the trailer king pin enters the hitch it will push the hitch jaws open and extend the handle (See Fig. 11). As king pin completely enters head, jaws will spring closed around king pin and handle will return to the closed position. (See Fig. 12)



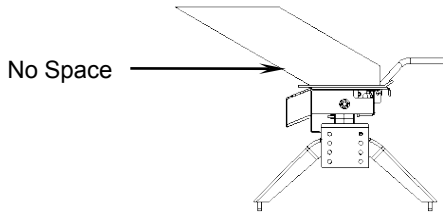
5. Use only the method described above for hitching.

⚠ WARNING:

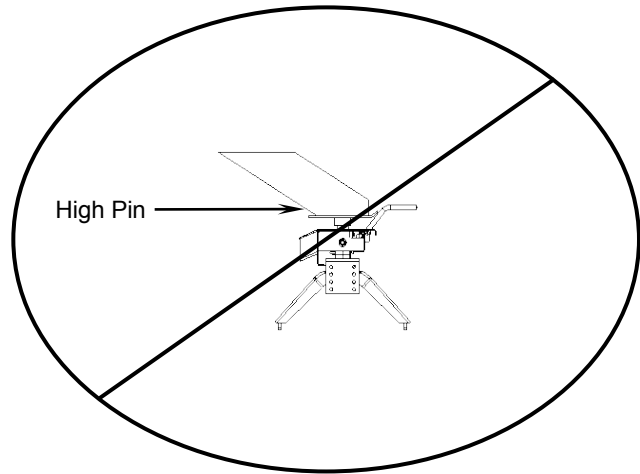
Do not attempt to hitch by using trailer jacks to lower trailer and king pin. This could result in king pin coming to rest on top of skid plate instead of within hitch opening where jaws are located. King pin could slide off hitch and trailer could drop, resulting in death or serious injury (See Fig. 13).



6. With all trailer wheels still firmly blocked, landing gear still resting on firm ground and supporting trailer weight, and truck stationary and in park with emergency brake on: visually check that bottom of pin box is resting on top of the hitch. THERE SHOULD BE NO SPACE BETWEEN THESE SURFACES (See Fig. 14). If space exists, (See Fig. 15) trailer has not been properly hitched. DO NOT TOW! Instead, repeat above steps until trailer is properly hitched. DO NOT PLACE BODY UNDER TRAILER TO PERFORM THIS INSPECTION!

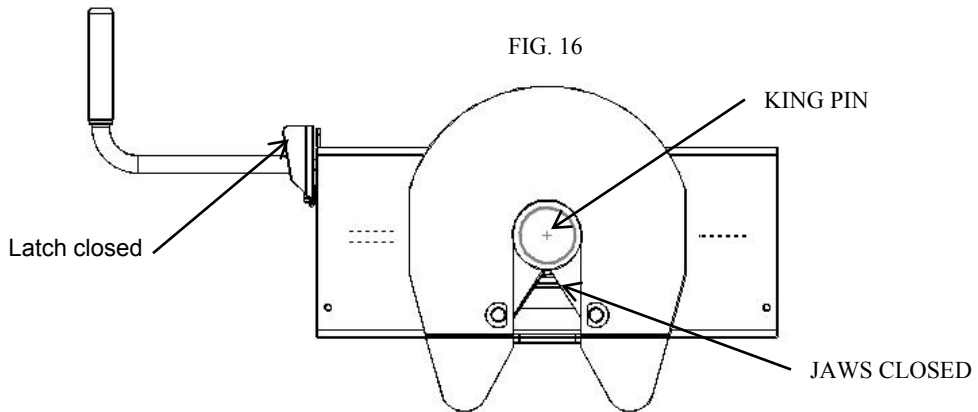


**Fig. 14
CORRECT**



**Fig. 15
WRONG**

7. Rotate latch for hitch handle to closed position in groove of handle to be sure hitch jaws are locked closed. IF LATCH IS NOT ALIGNED WITH GROOVE IN HANDLE, TRAILER HAS NOT BEEN PROPERLY CONNECTED TO HITCH. DO NOT TOW! Repeat above steps until trailer is properly hitched. (See Fig. 16)



8. With:

- All trailer wheels still firmly blocked in front and behind each tire, and
- Truck stationary with the emergency brake on, and
- Trailer landing gear still resting on firm ground and supporting trailer weight; and
- Truck stationary and with emergency brake on:

Connect electrical cable between truck and trailer, connect breakaway switch cable from pin box to a permanent part of truck, and raise tailgate of truck.

⚠ WARNING

•WHENEVER POSSIBLE, AVOID PUTTING BODY UNDER TRAILER OR BETWEEN TRUCK AND TRAILER

•If you need to place any part of your body under trailer or between truck and trailer:

- All trailer tires **MUST** be blocked in front and behind each tire **AND**
- Trailer landing gear **MUST** be resting on firm ground **AND**
- Truck **MUST** be stationary, in park, with emergency brake on!

PULL TEST

WARNING:

Failure to perform this test may result in death or serious injury!

1. With:

- All trailer wheels still firmly blocked, and
- Trailer land gear still resting on firm ground and supporting trailer weight and,
- Truck stationary and with emergency brake on:

Return to cab of truck and release truck's emergency brake. Apply trailer brakes. After making sure no one is between truck and trailer, try to pull trailer slowly forward with the truck. If the trailer is properly hitched, the wheel blocks and trailer brakes should keep the truck from moving forward.

NOTE: If trailer is not properly hitched, trailer will separate from hitch and truck will move forward leaving trailer behind. If the trailer landing gear is still on resting on firm ground supporting trailer weight and wheels are blocked, trailer will not be able to drop or fall

WARNING:

Failure to keep wheels blocked and landing gear down could result in trailer suddenly moving or falling. This could result in death or serious injury!

2. After successfully performing above steps, fully raise trailer landing gear (see trailer manual).
3. Check and inspect all electrical circuits for proper operation. (Clearance lights, turn signals, stop lights, etc.).
4. Remove and store all trailer wheel blocks.

UNHITCHING PROCEDURE:

PERFORM THE FOLLOWING IN THIS ORDER:

1. Place blocks firmly against front and rear of each trailer wheel to prevent any possible forward or rearward motion.
2. Using trailer jacks, lower trailer landing gear following the directions in the Trailer Manual until feet of landing gear are resting on firm ground.
3. Make sure truck is in park with the emergency brake on.

WARNING:

Trailers that are not stable or properly hitched can fall and kill you! To avoid death or serious injury:

- All trailer tires **MUST** be blocked in front and behind each tire **AND**
- Trailer landing gear **MUST** be resting on firm ground **AND**
- Truck **MUST** be stationary, in park, with emergency brake on!

4. Lower truck tail gate.
5. Disconnect power cable and breakaway switch cable between truck and trailer.
6. Rotate latch for hitch handle toward trailer and free of groove in handle. (Fig. 17 on next page)
7. Pull hitch handle out completely until it latches in open position so that king pin is no longer securely grasped by hitch jaws (See Fig. 18 on next page). Trailer is now free from hitch and truck. If handle does not pull out, there is probably pressure against the jaws. To relieve this pressure, back the truck slightly. Reset truck emergency brake. Then pull hitch handle out completely until it latches in open position. (See Fig. 18)

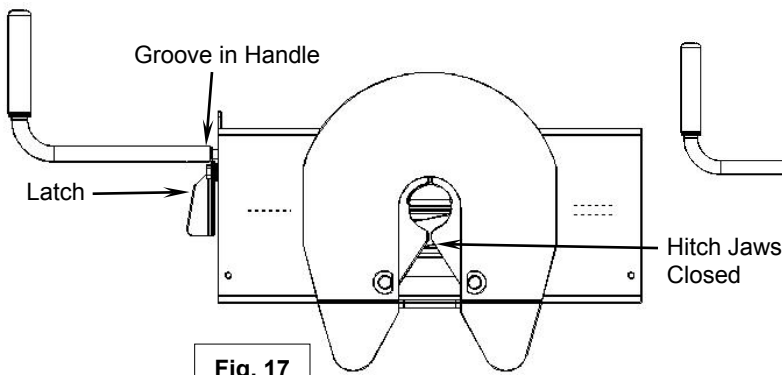


Fig. 17

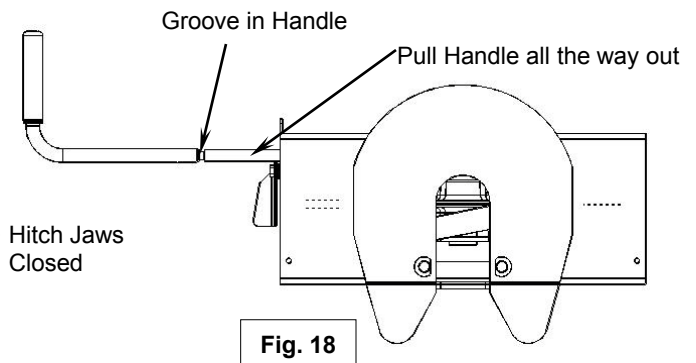


Fig. 18

8. AFTER MAKING CERTAIN NO ONE IS STANDING BETWEEN TRUCK AND TRAILER OR IN FRONT OF TRUCK, drive truck slowly away from trailer.

⚠ WARNING

Whenever possible, avoid putting body under trailer or between truck and trailer. If you need to place any part of our body under trailer or between truck and trailer:

- All trailer tires **MUST** be blocked in front and behind each tire **AND**
- Trailer landing gear **MUST** be resting on firm ground **AND**
- Truck **MUST** be stationary, in park, with emergency brake on!

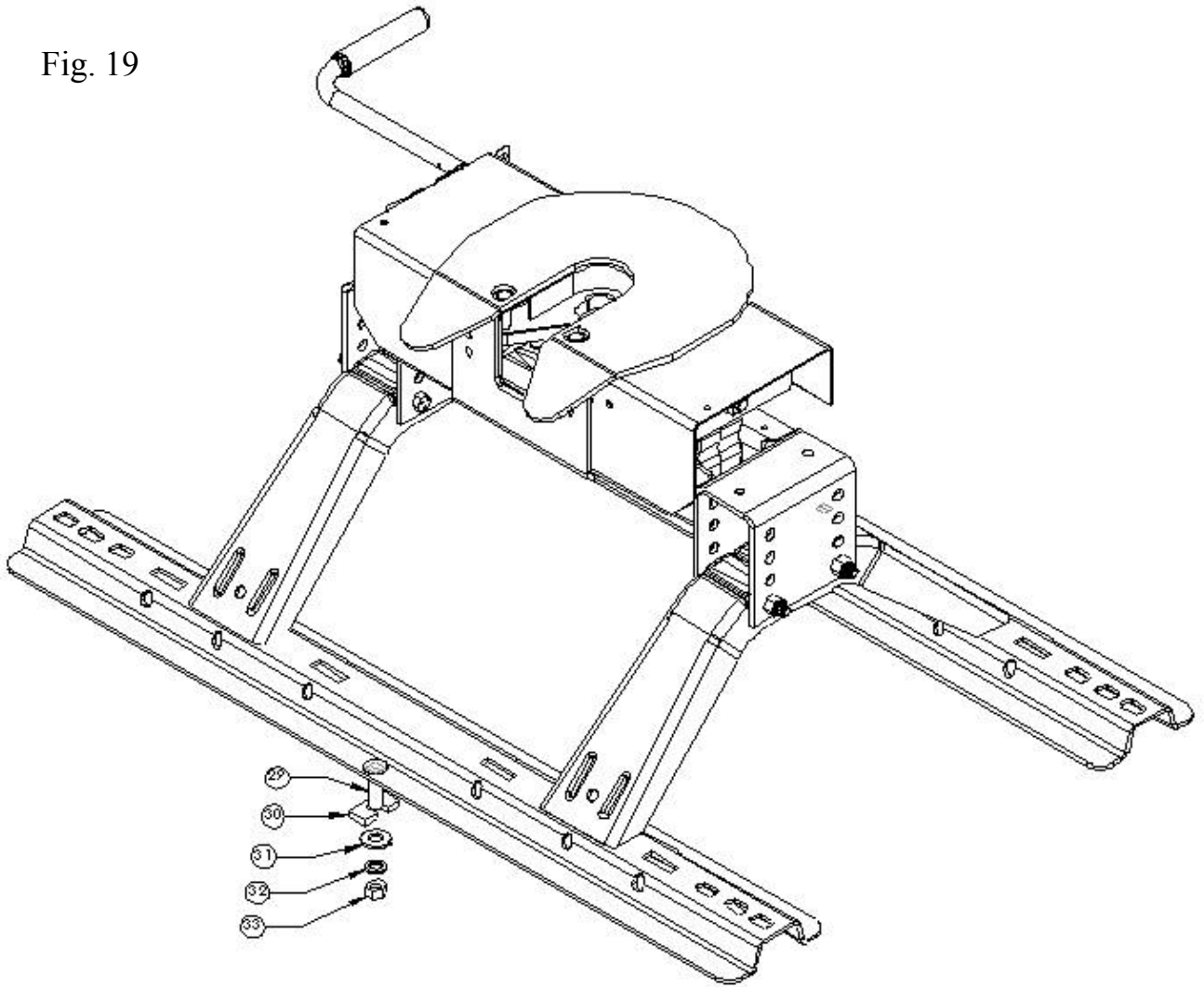
9. Close hitch jaws by pushing handle forward and up.
(Spring will close jaws.)

10. KEEP WHEEL BLOCKS IN PLACE. This will keep trailer from moving unexpectedly

MAINTENANCE:

1. Recheck tightness of all hardware every 1000 miles of use.
2. See "Before each trip" section in this manual.

Fig. 19

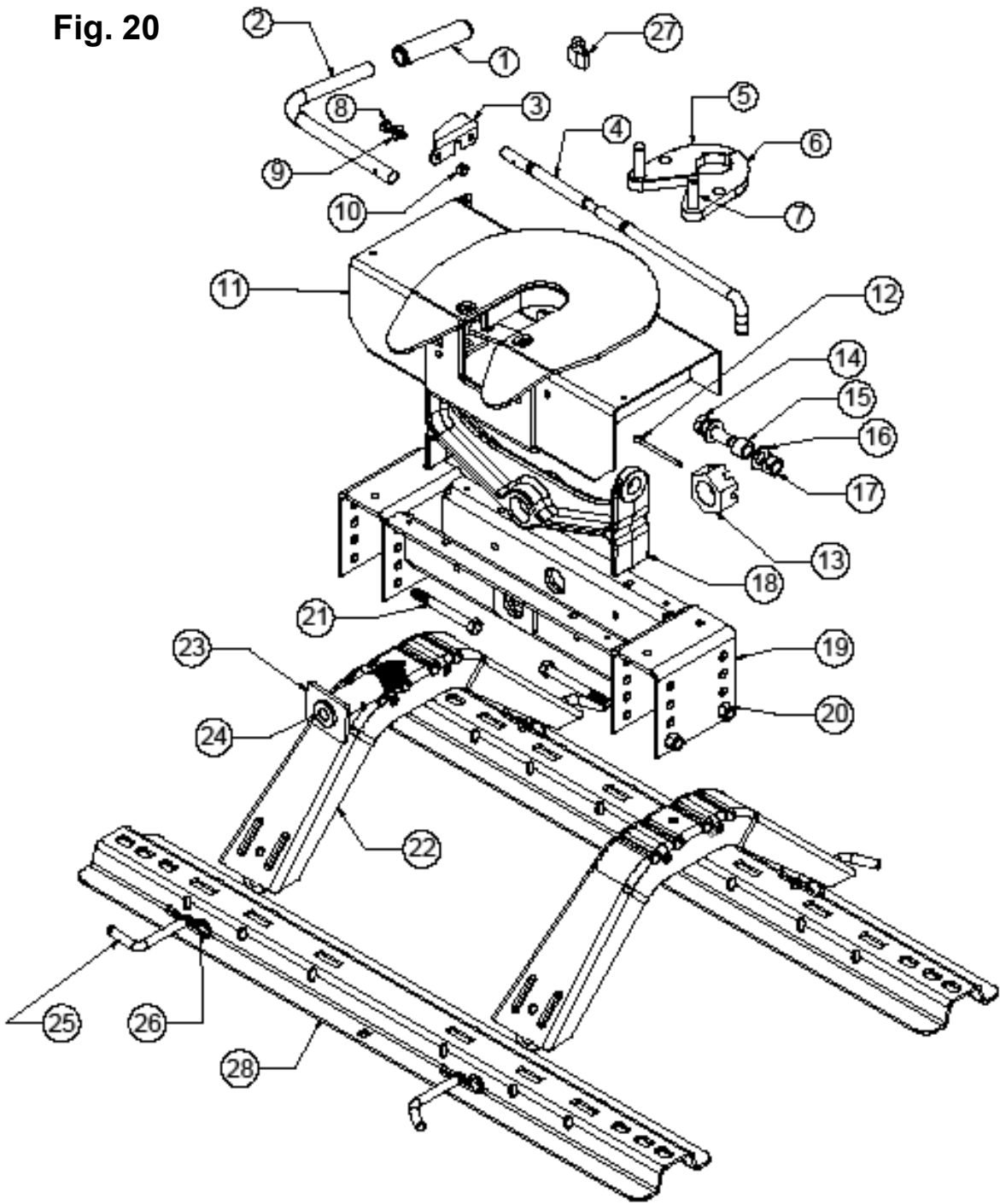


ADDITIONAL MOUNTING INSTRUCTIONS:

Install base rails as instructed in base rail instructions. The instruction below is for the addition of the 2 center bolts.

1. Place base rails in accordance with base rail mounting instructions. Try to keep them as close to the cross member under the bed as possible.
2. **BEFORE DRILLING ANY HOLES, CHECK FOR CLEARANCE AROUND THE GAS TANK.**
3. Using the center hole in the base rail as a guide, drill a 1/2" hole through the truck bed.
4. Insert 1/2" carriage bolt (29) into the hole. Install 1/2" serrated washer (31), 1/2" lock washer (32) and 1/2" nut (33).
5. Insert spacer (30) between the truck bed and the base rail. It will go in between at the corrugation of the bed.
6. Repeat for the other base rail.
7. Torque the 1/2" nuts to 75 ft/lbs.

Fig. 20



PCS.

- | | | | | | |
|-------------------------|-----|----------------------------|-----|----------------------------------|-----|
| 1. HANDLE GRIP | (1) | 14. 5/8-11 x 2 BOLT | (2) | 27. PAD LOCK | (1) |
| 2. TUBE HANDLE | (1) | 15. BUSHING | (2) | 28. BASE RAILS (SOLD SEPERATLEY) | |
| 3. LATCH | (1) | 16. 5/8" FLAT WASHER | (4) | | |
| 4. ACTUATING HANDLE | (1) | 17. 5/8-11 LOCKNUT | (2) | | |
| 5. LEFT JAW | (1) | 18. PIVOT BEAM | (1) | | |
| 6. RIGHT JAW | (1) | 19. HEAD SUPPORT | (1) | | |
| 7. PIVOT PIN | (2) | 20. 1/2-13 LOCKNUT | (4) | | |
| 8. 3/8-16 x 1-1/4" BOLT | (1) | 21. 1/2-13 x 4-1/2" BOLT | (4) | | |
| 9. 3/8" FLAT WASHER | (3) | 22. LEGS (SOLD SEPERATLEY) | (2) | | |
| 10. 3/8-16 LOCKNUT | (1) | 23. PIVOT PIN | (1) | | |
| 11. HEAD ASSEMBLY | (1) | 24. GREASE ZERK | (1) | | |
| 12. COTTER PIN | (1) | 25. PULL PIN | (4) | | |
| 13. 1-1/2-12 NUT | (1) | 26. SPRING CLIP | (4) | | |