



ITEM: 6502

DESCRIPTION: HITCH MOUNTED CARGO CARRIER

CONSUMER: Keep instructions and read before each use.

TOOLS REQUIRED:

3/4 Wrench

DO NOT EXCEED LOWER OF VEHICLE
TONGUE WEIGHT RATING OR 500 LBS.
MFR'S TONGUE WEIGHT RATING OR HITCH

APPROVED FOR USE WITH
Sequent Towing Products

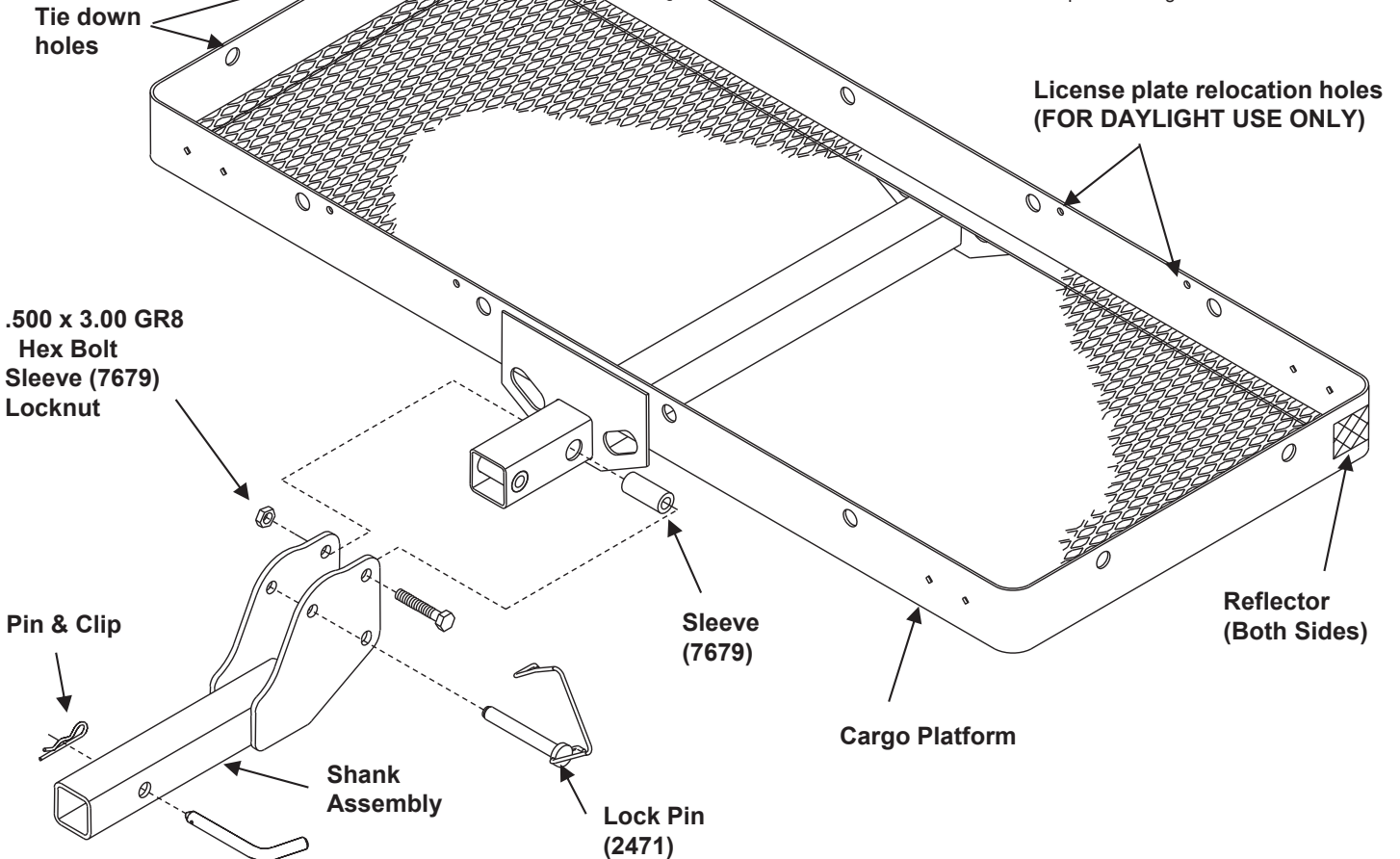

CARGO CARRIER ASSEMBLY:

FIGURE 1.

1. Place shank assembly in receiver hitch on vehicle and install pin & clip.
2. Insert sleeve (7679) into cargo platform. Attach cargo platform to shank with the .500 hex bolt and locknut.
3. Tighten .500 Gr8 hex bolt to 75 LB-FT. Slightly loosen hex locknut until shank moves freely. **IMPORTANT:** The hex locknut must be fully engaged onto hex bolt so nut is flush with end of bolt.
4. Insert lock pin (2471) through shank assembly and cargo platform.
5. Apply reflectors to rear corners of cargo platform as shown above.
6. Transport the cargo in the "up" position when unloaded.
7. If the vehicle license plate is obscured, relocate as shown in figure 2.
8. Attach clip to reminder card.

DASHBOARD REMINDER

During use attach the reminder card in a visible location near the driver (for example: a heating/cooling vent). **DO NOT** attach to rear view mirror or where it will obscure the view of the road.

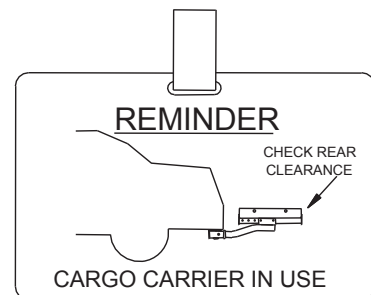



ITEM: 6502

DESCRIPTION: HITCH MOUNTED CARGO CARRIER

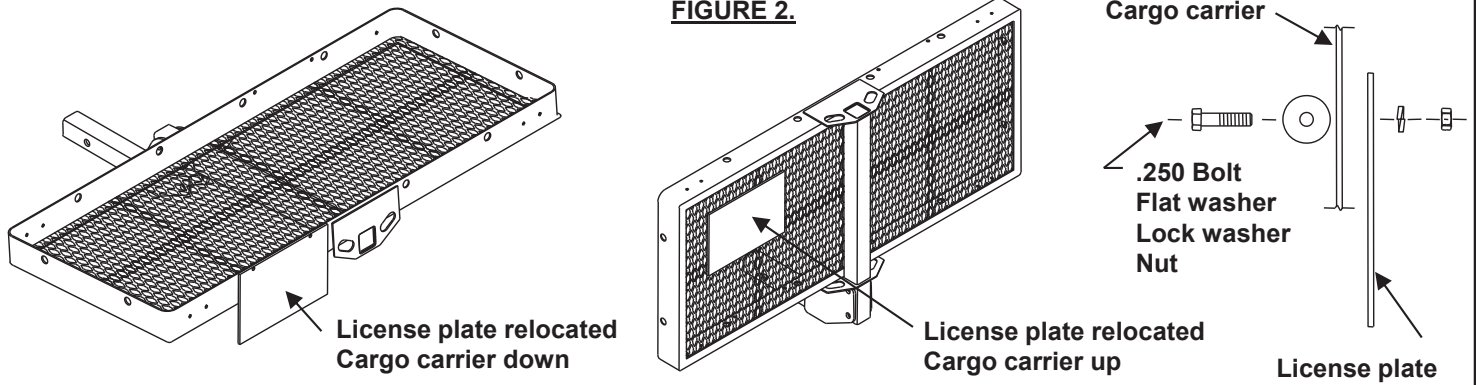

WARNING

- Not for transport of people, animals, or flammable liquids.
- If the load or cargo carrier blocks or impairs visibility of the taillights or turn signals, use optional light kit.
- If the cargo carrier or the contents being transported is in line with the exhaust outlet, an exhaust tip must be used to redirect the exhaust flow away from the cargo platform or contents.

CAUTION

- The cargo carrier load rating is the LOWEST of the following:
 - Cargo carrier rating
 - Hitch tongue weight rating
 - Vehicle manufacturer tongue weight rating
- The center of gravity of load must be positioned within the middle third of platform.

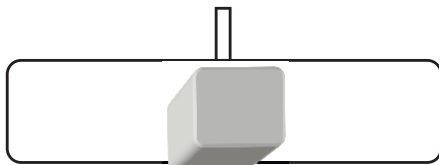

CORRECT

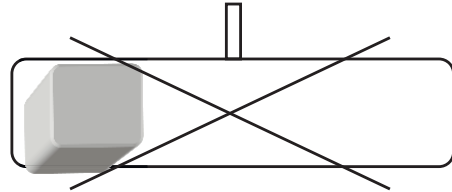

INCORRECT

- Do not lubricate threads. Bolt failure may occur due to over tightening.
- Securely fasten load to cargo carrier. Do not carry any loads wider than your vehicle.
- Check security of load, fasteners, pin, & clip at all fuel and rest stops.
Severe bumps can damage your towing vehicle, hitch and cargo carrier. Drive slowly on rough roads. Stop and make a thorough inspection if your cargo carrier strikes the road. Correct any problems before resuming travel.
- Do not cut, drill, weld, or modify this product.
- Do not carry loads wider than your vehicle.
- Relocate license plate if blocked by load or cargo carrier.
 - For daylight, relocate license plate to holes provided, see figure 1.
 - For nighttime, use optional light kit.