

Pro-Lift[®]

Hydraulic Floor Jack Combo

Operating Instructions & Parts Manual

Model Number
F-2330BMC

Capacity
2 Ton

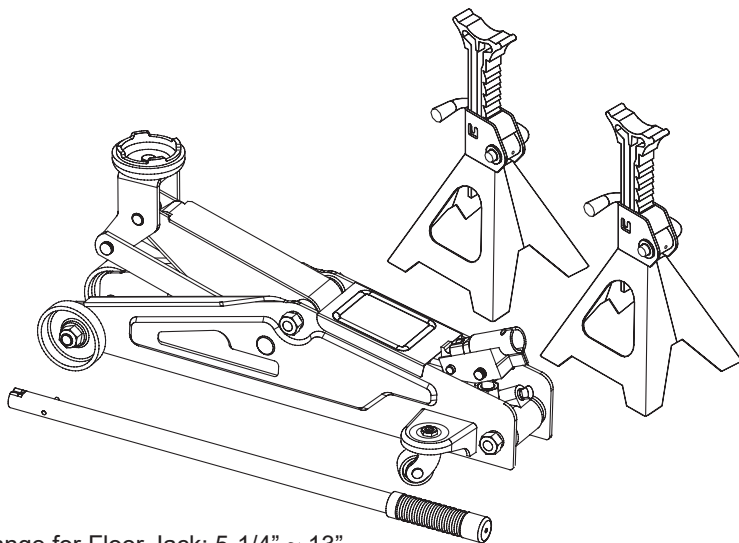

Lifting range for Floor Jack: 5-1/4" ~ 13"

Support range for Jack Stands (per pair): 10-1/2"~16-3/4"

⚠️ WARNING

To avoid **crushing and related injuries**:

- **NEVER** work on, under or around a load supported only by a hydraulic jack.
- **ALWAYS** use a pair of appropriately rated jack stands.



⚠️ WARNING: Cancer and Reproductive Harm.

2 Ton Floor Jack

Save these instructions. For your safety, read, understand, and follow the information provided with and on this jack. The owner and operator of this equipment shall have an understanding of this jack and safe operating procedures before attempting to use. The owner and operator shall be aware that use and repair of this product may require special skills and knowledge. Instructions and safety information shall be conveyed in the operator's native language before use of this jack is authorized. If any doubt exists as to the safe and proper use of this jack, remove from service immediately. **Inspect before each use.** Do not use if broken, bent, cracked, or damaged parts (including labels) are noted. Any jack that appears damaged in any way, operates abnormally or is missing parts, shall be removed from service immediately. If the jack has been, or suspected to have been subjected to a shock load (a load dropped suddenly, unexpectedly upon it), immediately discontinue use until jack has been checked by a factory authorized service center. It is recommended that an annual inspection be done by qualified personnel. Labels and Owner's Manuals are available from the manufacturer (see Replacement Parts, page 6).

PRODUCT DESCRIPTION

Pro-Lift Floor Jack is designed to lift, but not sustain, rated capacity loads. It is designed to be used in conjunction with jack stands. Pro-Lift Floor Jack has a unique feature which provides fast, no load lifts to the jacking point. **Intended use:** To lift one wheel or axle of a vehicle for the purpose of service and/or repair of vehicle components. After lifting, loads must be immediately supported by a pair of appropriately rated jack stands. Check with vehicle owner's manual for proper lift points.

BEFORE USE

1. Before using this product, read the owner's manual completely and familiarize yourself thoroughly with the product, its components and recognize the hazards associated with its use.
2. Using the stamped end of the provided handle, engage and turn the release valve counterclockwise no more than 1/2 full turns from a fully closed position.
3. With saddle fully lowered, locate and remove the oil filler plug. Insert the handle into the handle sleeve, then pump 6 to 8 full strokes. This will help release any pressurized air which may be trapped within the reservoir. Oil level should be ~3/16" above the inner cylinder as seen from the oil filler plug hole. Reinstall the oil filler plug.
4. Check to ensure that jack rolls freely (if so equipped) and that the pump operates smoothly before putting into service. Replace worn or damaged parts and assemblies with factory Authorized Replacement Parts only. (See Replacement Parts Section). Lubricate as instructed in Maintenance Section.

⚠WARNING

Study, understand, and follow all instructions before operating this device. Do not exceed rated capacity. Use only on hard, level surface. Lifting device only. Immediately after lifting, support the vehicle with appropriate means. Do not move or dolly the vehicle on the jack. Lift only on areas of the vehicle as specified by the vehicle manufacturer. No alteration shall be made to this product. Failure to heed these markings may result in personal injury and/or property damage.

⚠CAUTION

Be sure all tools and personnel are clear before lowering load. No alterations shall be made to this device. Only attachments and/or adapters supplied by the manufacturer shall be used. Lift only on areas of the vehicle as specified by the vehicle manufacturer.

OPERATION

Lifting (refer to Fig 1)

1. Place vehicle in park, with emergency brake on and wheels securely chocked to prevent inadvertent vehicle movement.
2. Close release valve by turning handle clockwise until firm resistance is felt Center jack saddle under lift point.
3. Verify lift point, then pump handle until saddle contacts lift point. To lift, pump handle until load reaches desired height.
4. Transfer the load immediately to appropriately rated jack stands (**always** use in pairs).

Lowering

1. Raise load high enough to clear jack stands, then carefully remove jack stands.
2. Slowly turn the handle counterclockwise, but no more than 1/2 full turn. If the load fails to lower:
 - a. Use another jack to raise the vehicle high enough to reinstall jack stands.
 - b. Remove the affected jack and then the stands.
 - c. Using the other jack, lower the load by turning the operating handle counterclockwise, but no more than 1/2 full turn.
3. After removing jack from under the load, push saddle down to reduce ram exposure to rust and contamination.

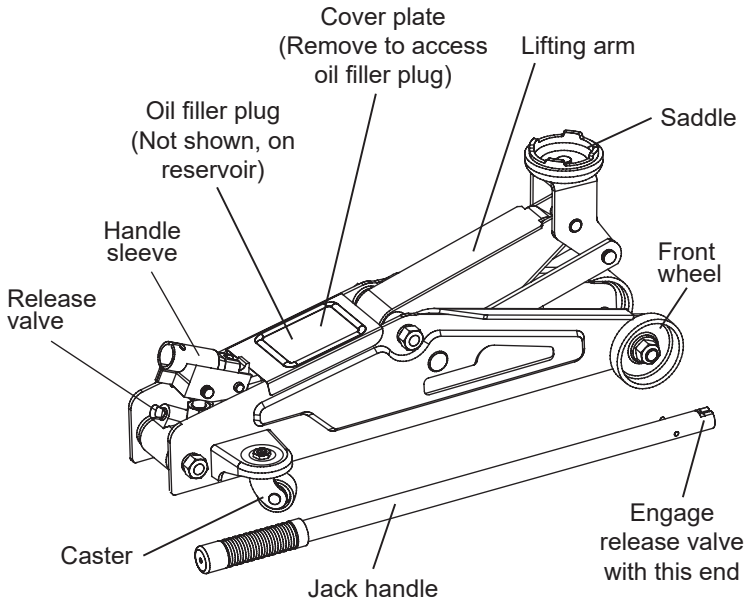

Figure 1 - Typical Floor Jack Nomenclature

MAINTENANCE

Important: Use only a good grade hydraulic jack oil (e.g. Mobil DTE 13M or equivalent). Avoid mixing different types of fluid and **Never** use brake fluid, turbine oil, transmission fluid, motor oil or glycerin. **Improper fluid can cause failure of the jack and the potential for sudden and immediate loss of load.**

Adding oil

1. With saddle fully lowered set jack in its upright, level position. Locate and remove oil filler plug.
2. Fill with oil until ~3/16" above the inner cylinder as seen from the oil filler plug hole. Reinstall the oil filler plug.

Changing oil

For best performance and longest life, replace the complete fluid supply at least once per year.

1. With saddle fully lowered, remove the oil filler plug.

TROUBLESHOOTING

Symptom	Possible Causes	Corrective Action
Jack will not lift load	<ul style="list-style-type: none"> • Release valve not closed • Overload condition 	<ul style="list-style-type: none"> • Ensure release valve tightly closed • Relieve overload condition
Jack pressure bleeds off after lift	<ul style="list-style-type: none"> • Release valve not closed • Overload condition • Hydraulic unit malfunction 	<ul style="list-style-type: none"> • Ensure release valve tightly closed • Relieve overload condition • Contact Customer Support
Jack will not lower after unloading	<ul style="list-style-type: none"> • Reservoir overfilled • Linkages binding 	<ul style="list-style-type: none"> • Drain fluid to proper level • Clean and lubricate moving parts
Jack exhibits poor lift performance	<ul style="list-style-type: none"> • Low fluid level • Air trapped in system 	<ul style="list-style-type: none"> • Ensure proper fluid level • With lift arm fully lowered, remove oil filler plug to allow pressurized air to escape, reinstall oil filler plug
Jack will not lift to full extension	<ul style="list-style-type: none"> • Low fluid level 	<ul style="list-style-type: none"> • Ensure proper fluid level

MAINTENANCE (continued)

2. Lay the jack on its side and drain the fluid into a suitable container.

Note: Dispose of hydraulic fluid in accordance with local regulations.

3. Fill with oil until ~3/16" above the inner cylinder as seen from the oil filler plug hole. Reinstall the oil filler plug.

Lubrication

A periodic coating of light lubricating oil to pivot points, axles and hinges will help to prevent rust and assure that wheels, casters and pump assemblies move freely.

Cleaning

Periodically check the pump piston and ram for signs of rust or corrosion. Clean as needed and wipe with an oily cloth.

Note: Never use sandpaper or abrasive material on these surfaces!

Storage

When not in use, store the jack with saddle fully lowered.

REPLACEMENT PARTS

Not all components of the jack are replacement items, but are illustrated as a convenient reference of location and position in the assembly sequence. When ordering parts, give model number, serial number and description below.

Model F-2330

Part No.	Description	Quantity
1	Power Unit	1
2	Front Wheel Assembly	2
3	Rear Caster Assembly	2
4	Saddle	1
5	Oil Filler Plug	1
6	Return Spring	1
7	Handle	1
8	Spring Clips	5
--	Labels	2
--	Owner's Manual	1

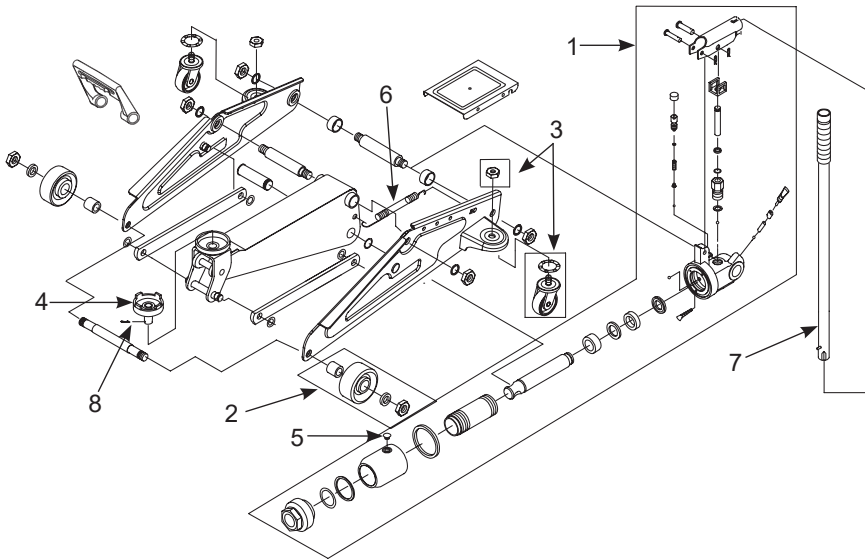

Figure 2 - Replacement Parts Illustration

2 Ton (Per Pair) Jack Stands

Save these instructions. For your safety, read and understand the information contained within. The owner and operator of this equipment shall have an understanding of this product and safe operating procedures before attempting to use this product. Instructions and safety information shall be conveyed in the operator's native language before use of this product is authorized. If any doubt exists as to the safe and proper use of this product as outlined in this factory authorized manual, remove from service immediately. **Inspect before each use.** Do not use if broken, bent, cracked, or damaged parts (including labels) are noted. If the jack stand has been or suspected to have been subjected to a shock load (a load dropped suddenly and unexpectedly upon it), discontinue use until checked out by an authorized factory service center. It is recommended that an annual inspection be done by qualified personnel and that any missing or damaged parts, decals, warning/safety labels or signs be replaced with factory authorized replacement parts only. Any jack stand that appears to be damaged in any way, is worn or operates abnormally shall be removed from service immediately.

PRODUCT DESCRIPTION

Pro-Lift Jack Stands are designed to safely support level, rated capacity loads, typically vehicles, for extended periods. Stamped steel construction and ductile iron ratchet bars ensure safety, strength and stability. Each comes with a ratchet/collar lock which prevents inadvertent loss of ratchet bar.

BEFORE USE

1. Inspect stands before each use. Do not use if bent, broken or cracked components are noted. Ensure that all parts move freely.
2. Before using this product, read the owner's manual and familiarize yourself thoroughly with the product and the hazards associated with its improper use.
3. Install ratchet bar into frame with ratchet portion of bar aligned with locking pawl (stopper).
4. Move the ratchet bar to its lowest position by raising the locking handle, thereby releasing the stopper, and guiding the bar downward.
5. Ratchet/collar lock is accomplished by simply moving the press tab (Fig. 3) inward using a suitable hammer and punch. This will effectively prevent inadvertent loss of the ratchet bar.
6. Always check the vehicle owners or service manual for location of proper lift and support points.

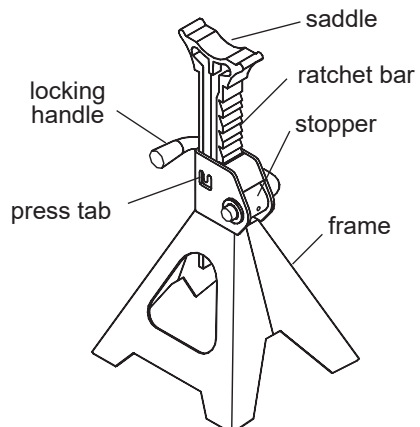

Figure 3 - Typical Jack Stand Nomenclature

⚠WARNING

Study, understand, and follow all instructions before operating this device. Do not exceed rated capacity. Use only on hard, level surface. Center load on saddle. Use as a matched pair only. Stands are not to be used to simultaneously support both ends of a vehicle. No alteration shall be made to this product. Failure to heed these markings may result in personal injury and/or property damage.

⚠CAUTION

Be sure all tools and personnel are clear before lowering load.

OPERATION

1. Adjust height by pulling up on ratchet bar.
2. The weight of the locking handle should secure the ratchet bar in desired position. To confirm this, simply push down on the locking handle. Check to ensure ratchet is secure before loading.
3. Carefully position jack stands so that load is centered on stand's saddle.
4. Slowly lower the vehicle onto the stands.
5. Check to ensure vehicle is secure before working on, around or under. When used to support vehicle, use wheel chocks to prevent inadvertent movement.

To lower load

1. With suitable jack, raise vehicle clear of stands.
2. Carefully release stopper and allow ratchet to glide down to lowest position.
3. Carefully remove stands, then carefully lower vehicle with lift device.
4. Ensure that all tools, equipment and personnel are clear before lowering load.

MAINTENANCE

Periodically inspect each stand. Ensure all parts move freely. Do not apply oil or grease to any portion of this product. If rust appears, sand affected area and cover with suitable utility paint. Please note that there are no replacement parts applicable to this device.

Storage

Store stands in upright position and in a clean, dry area.