

# Pro-Lift®

## Hydraulic Bottle Jacks

### Operating Instructions & Parts Manual

Models: B-002D, B-004D B-006D B-008D, B-012D, B-020D, B-S12D, B-S20D

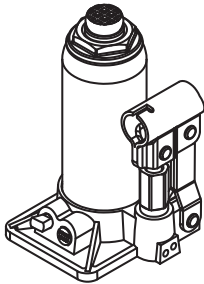

Models B-002D, B-004D, B-006D

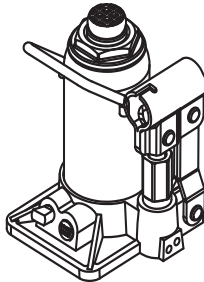

Models B-S12D, B-S20D

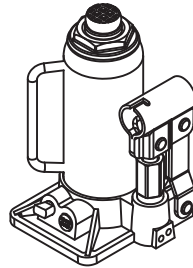

Models B-008D, B-012D, B-020D



*This is the safety alert symbol. It is used to alert you to potential personal injury hazards. Obey all safety messages that follow this symbol to avoid possible injury or death.*

### **!WARNING**



*To avoid crushing and related injuries: NEVER work on, under or around a load supported only by a hydraulic jack. ALWAYS use a matched pair of adequately rated jack stands.*

**!WARNING:** Cancer and Reproductive Harm.

**Read this manual and follow all the Safety Rules and Operating Instructions before using this product.**

## SAFETY AND GENERAL INFORMATION

**Save these instructions.** For your safety, read, understand, and follow the information provided with and on this device before using. The owner and/or operator shall have an understanding of the device, its operating characteristics and safety operating instructions before operating the equipment. The owner and/or operator shall be aware that use and repair of this product may require special skills and knowledge. Instructions and safety information shall be read to and discussed with the operator in the operator's native language, making sure that the operator comprehends their contents, before use of this equipment is authorized. If any doubt exists as to the safe and proper use of this device, remove from service immediately.

**Inspect before each use.** Do not use if abnormal conditions such as cracked welds, damaged, loose or missing parts are noted. Any equipment that appears damaged in any way, is found to be worn, or operates abnormally shall be removed from service until repaired. If the equipment has been or is suspected to have been subjected to an abnormal load or shock, immediately discontinue use until inspected by a factory authorized repair facility (contact distributor or manufacturer for list of authorized repair facilities). It is recommended that an annual inspection be made by an authorized repair facility. Labels and Operator's Manuals are available from the manufacturer.

## PRODUCT DESCRIPTION

Pro-Lift Hydraulic Bottle Jacks are designed to lift, not support, rated capacity loads consisting of one end of a vehicle. Immediately after lifting, the load must be supported by a matched pair of appropriately rated jack stands.

**⚠ WARNING:** *Never use hydraulic jack as a stand alone device. After lifting, immediately support the lifted load with a matched pair of appropriately rated jack stands.*

## SPECIFICATIONS

Model	Capacity	Base Size (L x W)	Min. Height	Max. Height	Extension Screw
B-002D	2 Ton	3-1/2" x 3-5/8"	7-1/8"	13-5/8"	1-7/8"
B-004D	4 Ton	4-1/4" x 4"	8"	15-1/2"	2-3/8"
B-006D	6 Ton	4-5/8" x 4-3/8"	8-1/2"	16-5/8"	3"
B-008D	8 Ton	4-5/8" x 4-5/8"	8-7/8"	17-1/4"	2-3/4"
B-012D	12 Ton	5-1/2" x 5-3/8"	9-1/2"	18-3/4"	3-1/8"
B-S12D	12 Ton	5-1/2" x 5-3/8"	6"	10 5/8"	1-5/8"
B-020D	20 Ton	6-3/8" x 6"	9-1/2"	18-3/4"	3-1/8"
B-S20D	20 Ton	6-3/8" x 6"	6-1/2"	11"	1-5/8"

## PREPARATION

### Before Use

1. Before using this product, read the operator's manual completely and familiarize yourself thoroughly with the product, its components and recognize the hazards associated with its use.
2. Verify that the product and application are compatible.
3. Assemble handle, ensure spring clips align with slots.
4. To familiarize yourself with basic operation, use the notched end of provided Pump Handle to engage and turn the Release Valve:
  - a. *Clockwise* until firm resistance is felt to further turning. This is the '**CLOSED**' Release Valve position used to raise the ram plunger.
  - b. *Counter-clockwise*, but no more than 1/2 turn from the closed position. This is the '**OPEN**' Release Valve position used to lower the Ram Plunger.
5. With Ram Plunger fully retracted and release valve closed, pump the operating handle. If Ram Plunger responds immediately, jack is ready for use. If jack does not respond, follow **Bleeding/Venting Trapped Air** instruction below.
6. Check that the pump operates smoothly and that the Extension Screw will thread up/down easily before putting into service. Replace worn or damaged parts and assemblies with Pro-Lift authorized replacement parts only.

### Bleeding/Venting Trapped Air

With the Release Valve in the OPEN position (step 4b above) and with Ram Plunger fully lowered, locate and remove the Oil Filler Plug/Screw. Insert the Pump Handle into the Handle Sleeve; then pump 6 to 8 full strokes. This will help release any pressurized air which may be trapped within the reservoir. Oil level should be even with the bottom of the oil filler hole. Reinstall the Oil Filler Plug/Screw.

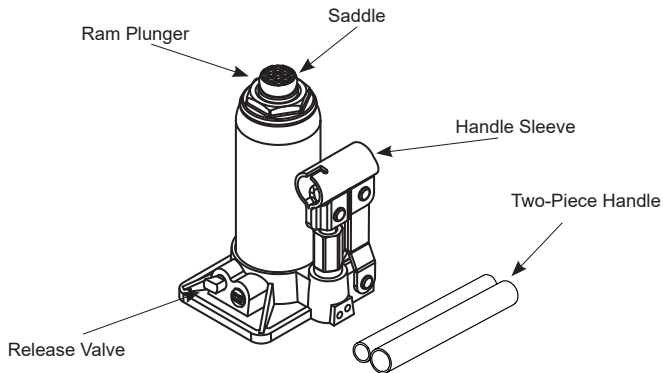

Figure 1 - Typical Bottle Jack Nomenclature (B-002D shown)

## **⚠WARNING**

- Study, understand, and follow all instructions before operating this device.
- Do not exceed rated capacity.
- Use only on hard, level surface capable of supporting the load.
- This is a lifting device only. Immediately after lifting, support the load with appropriate means.
- Lift only on areas of the vehicle as specified by the vehicle manufacturer.
- No alterations shall be made to this product.
- Only attachments and/or adapters supplied by the manufacturer shall be used.
- Failure to heed these markings may result in personal injury and/or property damage.

## **⚠WARNING**



To avoid crushing and related injuries:

- Never work on, under or around a load supported only by hydraulic jack.
- Always use adequately rated jack stands.
- Chock each unlifted tire in both directions.
- Do not use this device to lift, level, lower, support nor move a house, mobile home, travel trailer, camper or any building structure.
- Be alert and sober when using this product. Do not operate under the influence of drugs or alcohol.

## **OPERATION**

### **Raising the Ram Plunger**

1. Assemble Pump Handle, align spring clips with corresponding slots.
2. Place vehicle in park, with emergency brake on and wheels securely chocked to prevent inadvertent vehicle movement.
3. Locate and close Release Valve by turning Pump Handle clockwise until firm resistance is felt.
4. Verify lift point, center jack Saddle under lift point.
5. Insert Pump Handle into Handle Sleeve and pump to contact lift point. To lift, continue pumping until load reaches desired height.
6. Transfer the lifted load to a matched pair of appropriately rated jack stands.

**NOTICE:** Use Pump Handle provided by jack manufacturer. The handle provided with this jack will safely engage the release valve and operate the Handle Sleeve. If handle is worn, operates abnormally, or will not positively engage the release valve, STOP, discontinue use of the jack until a factory replacement handle can be acquired.

### **Lowering**

**⚠ WARNING:** Clear all tools and personnel before lowering load. Open release valve slowly. The further handle is turned counter-clockwise, the faster the load will descend. Maintain control of the load at all times.

1. Raise load high enough to clear the jack stands, then carefully remove jack stands.
2. Slowly turn the Pump Handle counter-clockwise, but no more than 1/2 turn. *If the load fails to lower:*
  - a. Use another jack to raise the vehicle high enough to reinstall jack stands.
  - b. Remove the affected jack and then the stands.
  - c. Use the functioning jack to lower the vehicle.
3. After removing jack from under the load, push Ram Plunger and Handle Sleeve down to reduce exposure to rust and contamination.

## MAINTENANCE

**NOTICE:** Use only good quality hydraulic jack oil. Avoid mixing different types of fluid and NEVER use brake fluid, turbine oil, transmission fluid, motor oil or glycerin. Improper fluid can cause premature failure of the jack and the potential for sudden and immediate loss of load. Premium hydraulic jack oil is recommended.

### Adding oil

1. With Ram Plunger fully lowered and pump piston fully depressed, set jack in its upright, level position. Remove Oil Filler Plug/Screw.
2. Fill with oil until just below the rim of the oil filler hole. Reinstall the Oil Filler Plug/Screw.

### Changing oil

For best performance and longest life, replace the complete fluid supply at least once per year.

1. With Ram Plunger fully lowered and pump piston fully depressed, remove the Oil Filler Plug/Screw.
2. Lay the jack on its side and drain the fluid into a suitable container.

**NOTICE:** Dispose of hydraulic oil in accordance with local environmental regulations.

3. Fill with oil until just below the rim of oil filler hole.
4. Perform Bleeding/Venting Trapped Air procedure (page 3). Reinstall the Oil Filler Plug/Screw.

### Lubrication

A periodic coating of light lubricating oil to pivot points, axles and hinges will help to prevent rust and assure that pump assemblies move freely.

### Cleaning

Periodically check the pump piston and Ram Plunger for signs of rust or corrosion. Clean as needed and wipe with an oily cloth.

**NOTICE:** Do not use sandpaper or abrasive material on ram or pump piston surfaces.

### Storage

When not in use, store the jack with pump piston and Ram Plunger fully retracted and air supply disconnected.

## TROUBLESHOOTING

Symptom	Possible Causes	Corrective Action
Jack will not lift load	<ul style="list-style-type: none"> <li>• Release Valve not tightly closed</li> <li>• Overload condition</li> </ul>	<ul style="list-style-type: none"> <li>• Ensure Release Valve tightly closed</li> <li>• Remedy overload condition</li> </ul>
Jack will lift, but not maintain pressure	<ul style="list-style-type: none"> <li>• Release Valve not tightly closed</li> <li>• Hydraulic unit malfunction</li> </ul>	<ul style="list-style-type: none"> <li>• Ensure Release Valve tightly closed</li> <li>• Contact Pro-Lift Tech. Service</li> </ul>
Jack will not lower after unloading	<ul style="list-style-type: none"> <li>• Reservoir overfilled</li> </ul>	<ul style="list-style-type: none"> <li>• Ensure load is removed, then drain fluid to proper level</li> </ul>
Poor lift performance	<ul style="list-style-type: none"> <li>• Fluid level low</li> <li>• Air trapped in system</li> </ul>	<ul style="list-style-type: none"> <li>• Ensure proper fluid level</li> <li>• Follow <b>Bleeding/Venting Trapped Air</b> procedure on page 3</li> </ul>
Will not lift to full extension	<ul style="list-style-type: none"> <li>• Fluid level low</li> </ul>	<ul style="list-style-type: none"> <li>• Ensure proper fluid level</li> </ul>

## REPLACEMENT PARTS

Not all components of the jack are replacement items. When ordering parts, give Model number, serial number and parts description.

### Replacement Parts List for Models B-002D, B-004D, B-006D

Item	Part No. for Models: B-002D, B-004D & B-006D	Description	Qty
1	F36100-0001	Oil Plug- Not Shown	1
2	B-006D-2	Handle Assembly	1

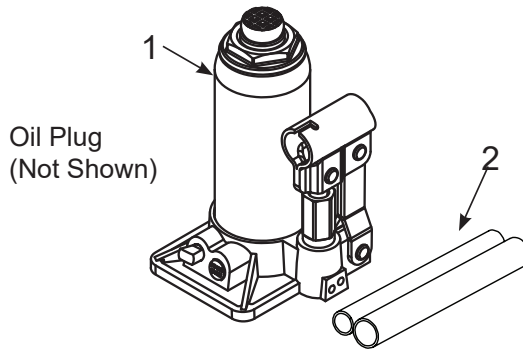

Figure 2 - Illustration for Models B-002D, B-004D & B-006D

---

Discover other car jacks on our website.