



off-road driven!™

---

**PRO COMP SUSPENSION**

***NOTE: WILL FIT VEHICLES EQUIPPED WITH THE TRD PACKAGE.***

***IMPORTANT!: 20" OR LARGER WHEELS MUST BE USED IN CONJUNCTION WITH THIS LIFT KIT! THE STOCK WHEELS CANNOT BE REUSED.***

*See page 7 for details.*

***NOTE: Installation of this kit will require trimming of tie rods. See step 73.***

**57048B**

**5079B**

**2007-2012 TOYOTA TUNDRA 4WD 4" KIT**

This document contains very important information that includes warranty information and instructions for resolving problems you may encounter. Please keep it in the vehicle as a permanent record.

Box 1 of 5/6-PN 57048B-1
--------------------------

Part #	Description	Qty.	Illus.	Page
<b>91-7319</b>	<b>FRONT CROSSMEMBER</b>	<b>1</b>	<b>2,3,5,6</b>	<b>9,11</b>
<b>90-6597</b>	<b>HARDWARE PACK: Crossmember</b>	<b>1</b>	<b>-</b>	<b>-</b>
71-181602501000	18mm-2.5 X 160mm 10.9 HEX BOLT	2	1,7	8,12
73-01810934	18mm FLAT WASHER	4	1,7	8,12
72-01810932	18mm-2.5 GR. C STOVER NUT	2	1,7	8,12
70-0875751800	7/8" X 5 3/4" GR. 8 HEX BOLT	2	2	9
73-08700832	7/8" FLAT WASHER	4	2	9
72-087100811	7/8" GR. C STOVER NUT	2	2	9
<b>90-6598</b>	<b>HARDWARE PACK: Cam Block Off</b>	<b>1</b>	<b>-</b>	<b>-</b>
<b>90-5010</b>	<b>CAM BLOCK OFF: 18mm</b>	<b>4</b>	<b>1,7</b>	<b>8,12</b>
<b>90-5011</b>	<b>CAM BLOCK OFF: 7/8"</b>	<b>4</b>	<b>2</b>	<b>9</b>
<b>91-7324</b>	<b>DIFF DROP: Drvr</b>	<b>1</b>	<b>4,6</b>	<b>10,11</b>
<b>90-6656</b>	<b>HARDWARE PACK: Pass Diff Drop</b>	<b>1</b>	<b>-</b>	<b>-</b>
90-2790	DIFF SPACER	4	4	10
73-05600034	9/16" SAE GR. 8 FLAT WASHER	3	4	10
90-2791	SPACERS DIFF DROP: Rear	1	4	10
73-01410940	14mm FLAT WASHER HARDENED	1	7	12
71-1403515008800	14mm-1.5 X 35mm HEX BOLT GR. 8.8	1	7	12
<b>90-6657</b>	<b>HARDWARE PACK: Diff Drops</b>	<b>4</b>	<b>-</b>	<b>-</b>
15-11326	BUSHING	2	4,7	10,12
90-2109	SLEEVE	1	4,7	10,12
<b>90-6704</b>	<b>HARDWARE PACK: Differential Drop Case Bolts</b>	<b>1</b>	<b>-</b>	<b>-</b>
71-100651251000	10mm-1.25 X 65mm HEX BOLT GR 10.: (1 Not Used)	2	4	10
73-01010934	10mm HARDENED FLAT WASHER	2	4	10
<b>91-7327</b>	<b>DIFF DROP: Rear</b>	<b>1</b>	<b>7</b>	<b>12</b>
<b>91-7330</b>	<b>DIFF DROP: Pass</b>	<b>1</b>	<b>4,6</b>	<b>10,11</b>
<b>90-6184</b>	<b>HARDWARE PACK:</b>	<b>1</b>	<b>-</b>	<b>-</b>
70-0504001800	1/2" X 4" HEX BOLT GR. 8	4	7	12
73-0500830	1/2" SAE FLAT WASHER	8	7	12
72-050100816	1/2" NYLOCK NUT	4	7	12
<b>90-6612</b>	<b>HARDWARE PACK: Pass Diff Drop</b>	<b>1</b>	<b>-</b>	<b>-</b>
70-0563501800	9/16" X 3 1/2" HEX BOLT GR 8	2	4	10
72-056100816	9/16" STOVER NUT	2	4	10
73-05600034	9/16" SAE HARDENED FLAT WASHER	4	4	10
<b>90-6613</b>	<b>HARDWARE PACK:Carrier Bearing Drop</b>	<b>1</b>	<b>-</b>	<b>-</b>
71-100601251000	10mm-1.25 X 50mm HEX BOLT 10.9	2	-	-
73-03700032	3/8" USS FLAT WASHER	2	-	-
90-1216	3/16" SPACER	2	-	-
90-1051	1/4" SPACER	2	-	-
90-2055	3/8" SPACER	2	-	-
90-2180	1/2" SPACER	2	-	-

Part #	Description	Qty.	Illus.	Page
90-2765	VENT HOSE: 1/4"	1	-	-
90-2766	VACUUM HOSE: 1/8"	1	-	-
91-7336	SWAY BAR DROPS	2	14	16
90-6340	<b>HARDWARE PACK: Sway Bar Drops</b>	1	-	-
70-0431251800	7/16" X 1 1/4" HEX BOLT GR. 8	4	14	16
72-043100816	7/16" STOVER NUT GR. C	4	14	16
73-0400830	7/16" SAE FLATWASHER	8	14	16
<b>Box 2 of 5/6-PN 57048B-2</b>				
90-4333	STEERING KNUCKLE- Driver	1	10,11,13	15
90-4334	STEERING KNUCKLE- Passenger	1	10,11,13	15
90-6453	<b>HARDWARE PACK: Bump Stop</b>	1	-	-
70-0622001800	ADEL CLAMP (w/ 10mm hole)	2	-	-
90-6602	<b>HARDWARE PACK: Knuckle</b>	1	-	-
71-180702501000	18mm-2.5 X 70mm 10.9 HEX BOLT	4	-	-
73-06200834	5/8" HARDENED FLAT WASHER	4	-	-
90-6454	<b>HARDWARE PACK: Steering Stop Extension Plate</b>	1	-	-
90-3399	STEERING STOP EXTENSION PLATE- Pass	1	10	15
90-3400	STEERING STOP EXTENSION PLATE- Drvr	1	10	15
90-6623	<b>HARDWARE PACK: Cotter Pin</b>	1	-	-
15N200PCOZ	5/32" x 2" COTTER PIN	4	-	-
12N150PCOZ	1/8" X 1 1/2" COTTER PIN	4	-	-
<b>Box 3 of 5/6-PN 57048B-3</b>				
91-7339	REAR CROSSMEMBER	1	1,4,7,8	8,10,11,13
91-5028	BUMP STOP REINFORCEMENT PLATE: Drvr Front	1	3	9
91-5027	BUMP STOP REINFORCEMENT PLATE: Pass Front	1	3	9
91-5029	BUMP STOP REINFORCEMENT PLATE: Drvr Rear	1	8	13
91-5032	BUMP STOP REINFORCEMENT PLATE: Pass Rear	1	8	13
90-6577	<b>HARDWARE PACK: Bump Stop</b>	4	-	-
70-0371001800	3/8" X 1" HEX BOLT GR. 8	4	3,8	9,13
72-037100816	3/8" STOVER NUT GR. C	4	3,8	9,13
73-03700034	3/8" HARDENED FLAT WASHER	8	3,8	9,13
90-6441	<b>HARDWARE PACK: Bump Stop</b>	2	-	-
71-100301251000	10mm-1.25 X 30mm HEX 10.9	2	3,8	9,13
72-01010932	10mm-1.25 STOVER NUT GR. C	2	3,8	9,13
73-01010934	10mm HARDENED FLAT WASHER	4	3,8	9,13

Part #	Description	Qty.	Illus.	Page
<b>90-6615</b>	<b>HARDWARE PACK: Brake Line Drops</b>	<b>1</b>	<b>-</b>	
55089-3	<b>BRAKE LINE FRONT: Drvr</b>	<b>1</b>	<b>12</b>	<b>15</b>
55089-4	<b>BRAKE LINE FRONT: Pass</b>	<b>1</b>	<b>12</b>	<b>15</b>
<b>90-5035</b>	<b>REAR BRAKE LINE DROP</b>	<b>2</b>	<b>-</b>	<b>-</b>
<b>90-1083</b>	<b>REAR EMERGENCY BRAKE LINE DROPS</b>	<b>2</b>	<b>-</b>	<b>-</b>
<b>90-6604</b>	<b>HARDWARE PACK: Rear Brake Line</b>	<b>1</b>	<b>-</b>	<b>-</b>
70-0371001800	3/8" X 1" HEX BOLT GR. 8	2	15	18
72-037100816	3/8" STOVER NUT GR. C	2	15	18
73-03700034	3/8" HARDENED FLAT WASHER	2	15	18
73-03700032	3/8" USS FLAT WASHER	2	15	18
<b>90-6299</b>	<b>HARDWARE PACK: Front Brake Lines/Rear E Brake</b>	<b>2</b>	<b>-</b>	<b>-</b>
70-0311001800	5/16" X 1" HEX BOLT GR. 8	2	15	18
72-0531100816	5/16" NYLOCK NUT	2	15	18
73-03100034	5/16" HARDENED FLAT WASHER	4	15	18
<b>95-102</b>	<b>1" LIFT BLOCK</b>	<b>2</b>	<b>16</b>	<b>19</b>
<b>13-90126</b>	<b>U-BOLTS: 9/16" x 2.525" x 10.00"</b>	<b>4</b>	<b>16</b>	<b>19</b>
<b>20-65302</b>	<b>HARDWARE PACK: U-Bolts</b>	<b>1</b>	<b>-</b>	<b>-</b>
13-30330	9/16" FLAT WASHER	8	16	19
13-10423	9/16" HIGHNUT	8	16	19
<b>Box 4 of 5-PN 57048B-4</b>				
<b>927591</b>	<b>ES SERIES REAR SHOCK</b>	<b>2</b>	<b>-</b>	<b>-</b>
<b>90-6610</b>	<b>HARDWARE PACK: Spacer Mount</b>	<b>1</b>	<b>-</b>	<b>-</b>
72-043200810	7/16" GR. 8 HEX NUT	8	9b	14
73-04300830	7/16" SAE FLAT WASHER	8	9b	14
73-04300836	7/16" SPLIT LOCK WASHER	8	9b	14
<b>91-4178</b>	<b>PRELOAD SPACER</b>	<b>2</b>	<b>9a</b>	<b>14</b>
<b>91-8172</b>	<b>STRUT SPACER: Pass</b>	<b>1</b>	<b>9a</b>	<b>14</b>
<b>91-8170</b>	<b>STRUT SPACER: Drvr</b>	<b>1</b>	<b>9a</b>	<b>14</b>
<b>Box 5/6MX of 5/6-PN 57096B-5</b>				
<b>13129-1</b>	<b>ADD-A-LEAF</b>	<b>2</b>	<b>15</b>	<b>19</b>
<b>90-3825</b>	<b>HARDWARE PACK: Add-A-Leaf</b>	<b>1</b>	<b>-</b>	<b>-</b>
98-00250-1	2 1/2" SPRING PLATE- CLAMPS	4	15	19
98-00250-1	2 1/2" SPRING PLATE- STRAPS	4	15	19
97-380	3/8" X 5" CENTER BOLT	2	15	19
8337-1	3/8" FINE GR. 8 NUT	2	15	19

## Introduction:

- ◆ This installation requires a professional mechanic!
- ◆ We recommend that you have access to a factory service manual for your vehicle to assist in the disassembly and reassembly of your vehicle. It contains a wealth of detailed information.
- ◆ Prior to installation, carefully inspect the vehicle's steering and driveline systems paying close attention to the tie rod ends, ball joints, wheel bearing preload, pitman and idler arm. Additionally, check steering-to-frame and suspension-to-frame attaching points for stress cracks. The overall vehicle must be in excellent working condition. Repair or replace all worn or damaged parts!
- ◆ Read the instructions carefully and study the illustrations before attempting installation! You may save yourself a lot of extra work.
- ◆ Check the parts and hardware against the parts list to assure that your kit is complete. Separating parts according to the areas where they will be used and placing the hardware with the brackets before you begin will save installation time.
- ◆ Check the special equipment list and ensure the availability of these tools.
- ◆ Secure and properly block vehicle prior to beginning installation.
- ◆ ALWAYS wear safety glasses when using power tools or working under the vehicle!
- ◆ Use caution when cutting is required under the vehicle. The factory undercoating is flammable. Take appropriate precautions. Have a fire extinguisher close at hand.
- ◆ Foot pound torque readings are listed on the Torque Specifications chart at the end of the instructions. These are to be used unless specifically directed otherwise. Apply thread lock retaining compound where specified.
- ◆ **Please note that while every effort is made to ensure that the installation of your Pro Comp lift kit is a positive experience, variations in construction and assembly in the vehicle manufacturing process will virtually ensure that some parts may seem difficult to install. Additionally, the current trend in manufacturing of vehicles results in a frame that is highly flexible and may shift slightly on disassembly prior to installation. The use of pry bars and tapered punches for alignment is considered normal and usually does not indicate a faulty product. However, if you are uncertain about some aspect of the installation process, please feel free to call our tech support department at the number listed on the cover page. We do not recommend that you modify the Pro Comp parts in any way as this will void any warranty expressed or implied by the Pro Comp Suspension company.**

## **Important!**

Tire and wheel choice is crucial in assuring proper fit, performance, and the safety of your Pro Comp equipped vehicle. For this application, a 20" wheel not to exceed 9" in width with a maximum backspacing of 6" must be used. Additionally, a quality tire of radial design, not exceeding 35" tall X 12.5" wide is recommended. Please note that the use of a 35" X 12.5" tire may require the removal of the front inner fender mud flaps (front and rear). Violation of these recommendations will not be endorsed as acceptable by Pro Comp Suspension and will void any and all warranties either written or implied.

***IMPORTANT!: 20" OR LARGER WHEELS MUST BE USED  
IN CONJUNCTION WITH THIS LIFT KIT! THE STOCK  
WHEELS CANNOT BE REUSED***

## **Please Note:**

- \* Front suspension and head light realignment is necessary!
- \* Speedometer and ABS recalibration will be necessary if larger tires (10% more than stock diameter) are installed.
- \* Always use NEW cotter pins on re-assembly! (These items are NOT supplied)
- \* **IT IS ADVISABLE THAT YOU HAVE HELP AVAILABLE WHEN INSTALLING THIS KIT. SOME COMPONENTS ARE HEAVY AND AWKWARD. ADDITIONAL HELP IS GOOD INSURANCE AGAINST INJURY!**

## **Special Tools:**

Please refer to your service manual for more information.  
A special removal tool is required for safe removal of the tie rods.  
These tools may be purchased at your local Toyota dealer.  
You may be able to rent any of these tools at your local parts store.



### **Optional Equipment Available from your Pro Comp Distributor!**

**Traction Bars: 72500B  
Skid Plate: 57197**

**Mounting kit: 72077B**

Also, Check out our outstanding selection of Pro Comp tires to compliment your new installation!

# Front Installation:

1. Prior to installing this kit, with the vehicle on the ground. Measure the height of your vehicle. This measurement can be recorded from the center of the wheel, straight up to the top of the inner fender lip. Record the measurements below.

LF: \_\_\_\_\_ RF: \_\_\_\_\_

LR: \_\_\_\_\_ RR: \_\_\_\_\_

2. Ensure that your work space is of adequate size and the work surface is level. Place the vehicle in park. Disconnect the negative battery cable from the battery. Place your floor jack under the front cross member and raise vehicle. Place jack stands under the frame rails behind the front wheel wells and lower the frame onto the stands. Remove the jack and place the vehicle back in gear, set the emergency brake, and place blocks both in front of and behind the rear wheels. Remove the front wheels.
3. Remove the skid plate from the vehicle and discard. Save these bolts for skid plate (**57197 Sold Separately**) installation.
4. Work on one side of the vehicle at a time.
5. Using the appropriate tool, remove the outer tie rod end nut. Separate using the appropriate tool.
6. Unbolt the front brake line brackets from the frame. Save the bolts for reinstallation
7. Un clip and unbolt the ABS line from the back of the knuckle. Unbolt the anti-lock brake sensor from the hub. Unbolt the upper brake line bracket from the knuckle.
8. Remove the brake caliper from the rotor and secure them clear from the work area. **DO NOT** let the caliper hang by the brake line or damage may result.
9. Remove the front rotor from the front hub.
10. Remove the dust cap from the hub. Remove the cotter pin and retaining nut from the cen-

ter of the bearing hub.

11. Unbolt the (**4**) bolts holding the hub flange to the knuckle and remove the hub and backing plate. Save the hub for reinstallation.

***NOTE: You will not be able to remove the bolts from the hub assembly after the hub is removed from the knuckle.***

12. Unbolt the sway bar end links from the lower A-arm. Unbolt the sway bar frame mount brackets and remove the sway bar. Save the parts and hardware for reuse.
13. Support the knuckle and remove the upper ball joint nut from the knuckle. Separate using the appropriate tool.
14. Remove the (**2**) bolts from the lower ball joint bracket.
15. Remove the knuckle from control arm assembly.
16. Unbolt and remove the factory strut assembly from the vehicle. Save the hardware for reuse.  
***NOTE: The lower A-arm bolts may need to be loosened in order to release pressure on the strut.***
17. Unbolt and remove the lower A-arm from the vehicle.
18. Remove the front bump stops from the frame. Save the bump stop for reinstallation.  
***NOTE: Be sure to support the CV axles before removing the lower A-arm. DO NOT allow the axles to hyperextend or damage to the bearings might result.***
19. Repeat steps 4 through 18 on the remaining side of the vehicle.
20. Unbolt the front driveshaft from the differential. Secure the driveshaft up and out of the work area.
21. Unclip all electrical wiring, vacuum lines and vent lines from the differential.
22. Support the differential with a jack and unbolt the rear mount differential mount. This

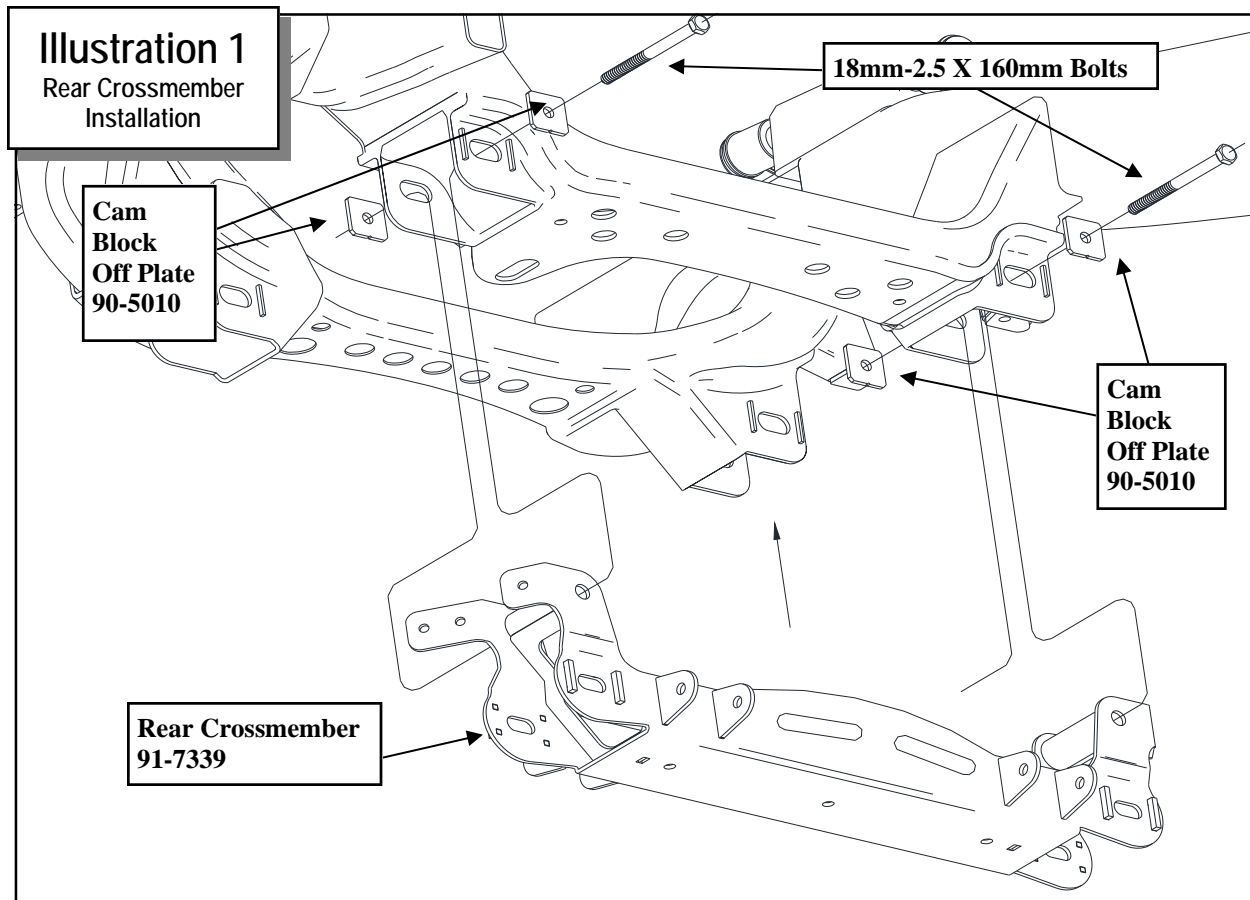

bracket will not be reused.

23. Unbolt the (2) front differential mount bolts from the front crossmember. Carefully remove the differential from the vehicle.
24. Install the front crossmember (91-7319) into the front mounting pockets using the supplied 7/8" X 5 3/4" bolts and cam block off plates (90-5011). Install the cam block off plates with the notches facing down. See ILLUSTRATION 2.

**NOTE:** *Due to variations in frame tolerances from the factory, the holes in the cam block off plates are offset to provide adjustability. If the bolt holes do not line up with the cam block off plate notches facing down they can be rotated to aid in installation of the cam bolts. In order for the crossmember to stay centered in the vehicle the notches in the cam block off plates must be facing the same way on both driver and passenger sides. Ex. Both notches facing up, down, in or out.*

25. Install the previously removed **OE** bump stop into the front crossmember using the supplied nut and washer from pack (90-6441). See ILLUSTRATION 2.
26. Install the front bump stop reinforcement plates (91-5028 **drv**r and 91-5027 **pass**) and secure the upper mounting hole in the frame using the supplied 10mm X 30mm bolt. Leave bolt loose at this time. See ILLUSTRATION 3.
27. Install the 3/8" X 1" bolts through the side mounting holes. Be sure that the heads of the bolts are facing toward the outside of the crossmember. See ILLUSTRATION 3.

**NOTE:** *The side holes are slotted for easier alignment.*

28. Remove the (2) front differential mounting brackets from the differential. These brackets will not be reused.
29. Install the supplied bushings and sleeves from hardware pack (90-6657) into differential mounts (passenger side differential mount 91-



**7330**, driver side front differential mount **91-7324**, and the rear differential mount **91-7327**). See ILLUSTRATION 4.

30. Remove the (2) **OE** differential case bolts, above the (3) **OE** mounting bolts, these bolts will not be reused. See ILLUSTRATION 4.
31. Unbolt the **OE** vacuum hard line bracket from the differential. Save **OE** bolt for reinstallation.
32. Install the driver side differential mount (**91-7324**) to the differential using the (3) **9/16"** washers and previously removed **OE** bolts and the (2) supplied **10mm X 65mm** bolts and **10mm** hardened washers. Leave bolts slightly loose. See ILLUSTRATION 4.
33. Install the supplied passenger side differential mount (**91-7330**) to the differential using the (4) supplied spacers (**90-2790**) and supplied **9/16" X 3 1/2"** bolts and hardware from pack (**90-6656**). Leave bolts slightly loose. See ILLUSTRATION 4.
34. Support the CV axles and carefully raise the differential assembly into place.

**NOTE: DO NOT** allow the axles to hyperextend or damage to the bearings might result.

35. Secure the front driver differential mount (**91-7324**) and passenger side differential mount (**91-7330**) to the front crossmember using the supplied **1/2" X 4"** bolts and hardware. See ILLUSTRATION 6.
36. Install the rear crossmember (**91-7339**) into the rear frame mounting pockets using the supplied **18mm-2.5 X 160mm 10.9** bolts and cam block off plates (**90-5010**). Install the cam block off plates with the notch facing up. See ILLUSTRATION 7.

**NOTE: Carefully guide the rear of the passenger side differential mount (90-7327) into the mounting tabs on the rear crossmember during installation.**

37. Secure the passenger side rear differential mount (**91-7330**) to the rear crossmember

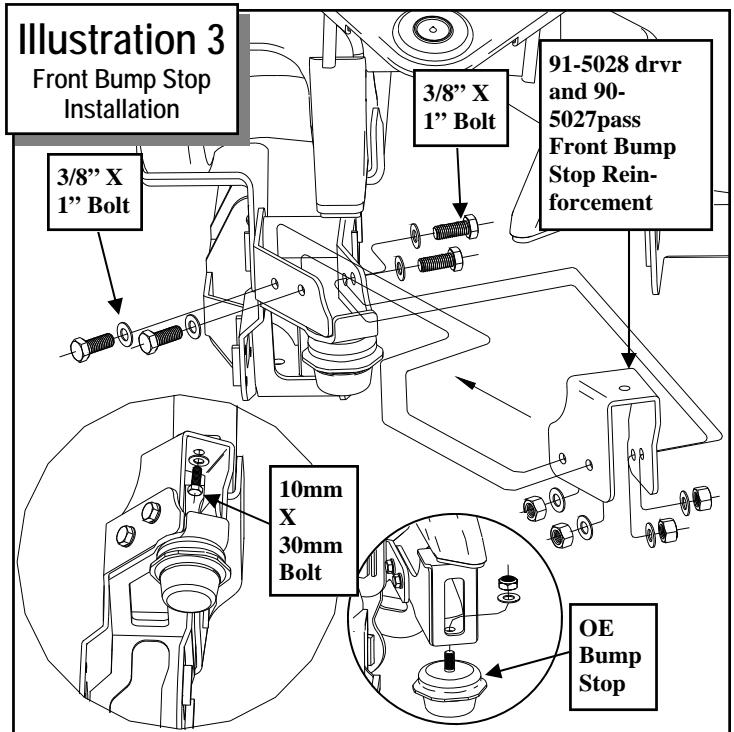
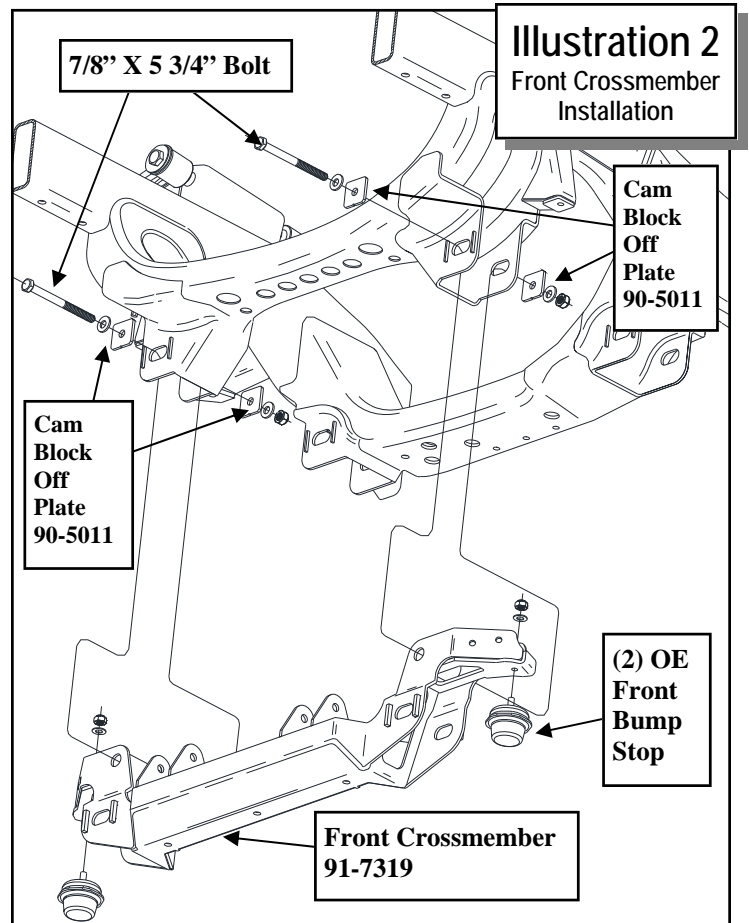

**Illustration 4**  
Front Diff Mount  
Installation

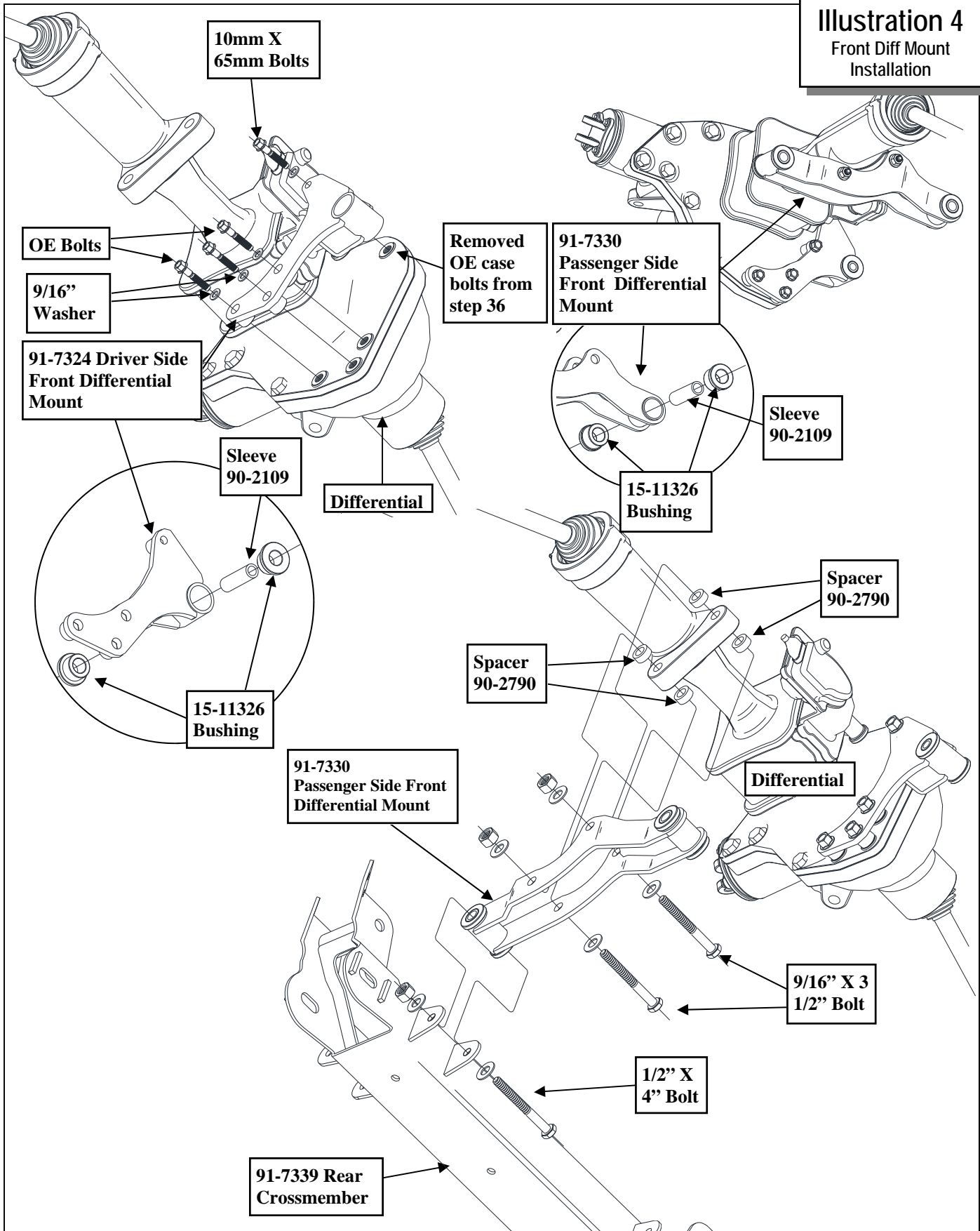

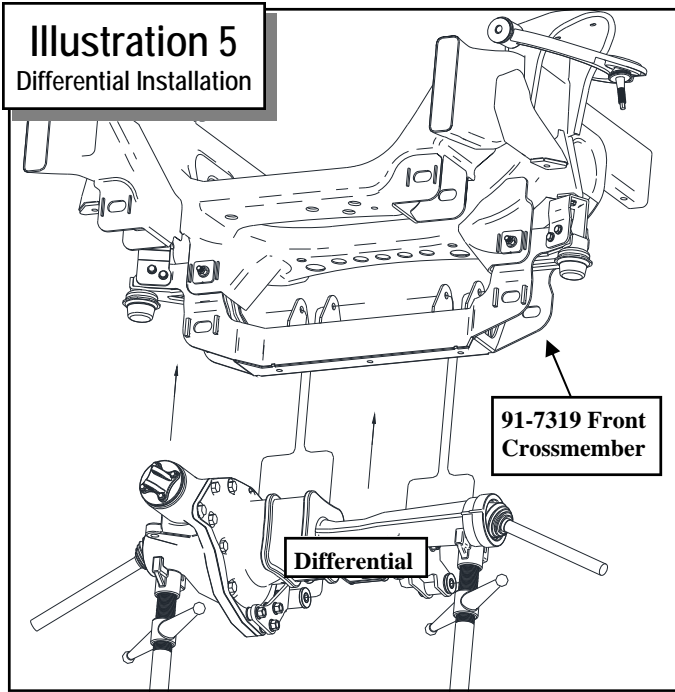

**Illustration 5**  
Differential Installation

mounting tabs using the supplied 1/2" X 4" bolt and hardware. See ILLUSTRATION 4.

- 38. Secure the rear differential mount (91-7327) to the differential using the supplied 14mm X 35mm bolt, 14mm hardened washer and spacer (90-2791). See ILLUSTRATION 7.
- 39. Secure the rear differential mount to (91-7327) to the mounting tabs on the rear crossmember (91-7339) using the supplied 1/2" X 4" bolt and hardware. See ILLUSTRATION 7.
- 40. Reinstall the differential vacuum bracket using the previously removed OE bolt.
- 41. Install the previously removed OE bump stop

into the bump stop reinforcement plate (91-5029 and 91-5032) using the supplied nut and bolt from pack (90-6441).

- 42. Install the rear bump stop reinforcement plates (91-5029 **drvr** and 91-5032 **pass**) and secure the upper mounting hole to the frame using the supplied 10mm X 30mm bolt. Leave bolt loose at this time. See ILLUSTRATION 8.
- 43. Install the 3/8" X 1" bolts from pack (90-6577) through the side mounting holes. Be sure that the heads of the bolts are facing toward the outside of the crossmember. See ILLUSTRATION 8.

*NOTE: The side holes are slotted for easier alignment.*

- 44. In order to accommodate the new differential position, replace the existing differential vacuum and vent lines with the supplied 1/4" vent line (90-2765) and 1/8" vacuum line (90-2766).
- 45. Reconnect all the differential electrical, vacuum and vent connections. Reattach the front driveshaft and torque the OE nuts to 65 ft./lbs.
- 46. Install the lower A-arms into the front and rear crossmember mounting pockets. Secure using the OE cam bolts.
- 47. Torque all crossmember and differential bolts according to the torque chart on page 21. Be sure torque the upper bump stop mounting hardware first. Torque the 7/8" front cross-

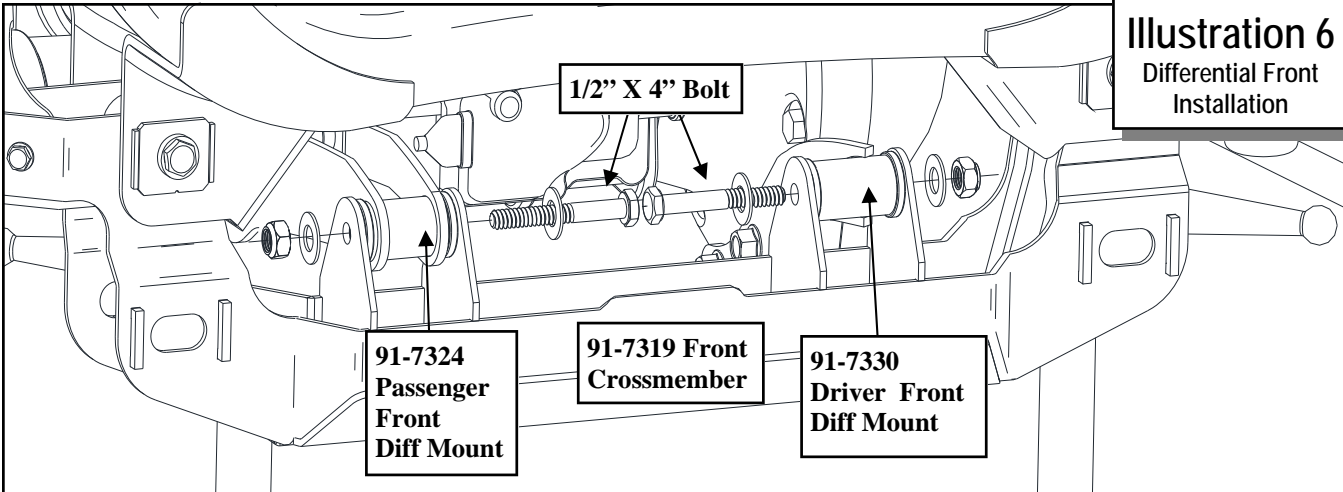

**Illustration 6**  
Differential Front Installation

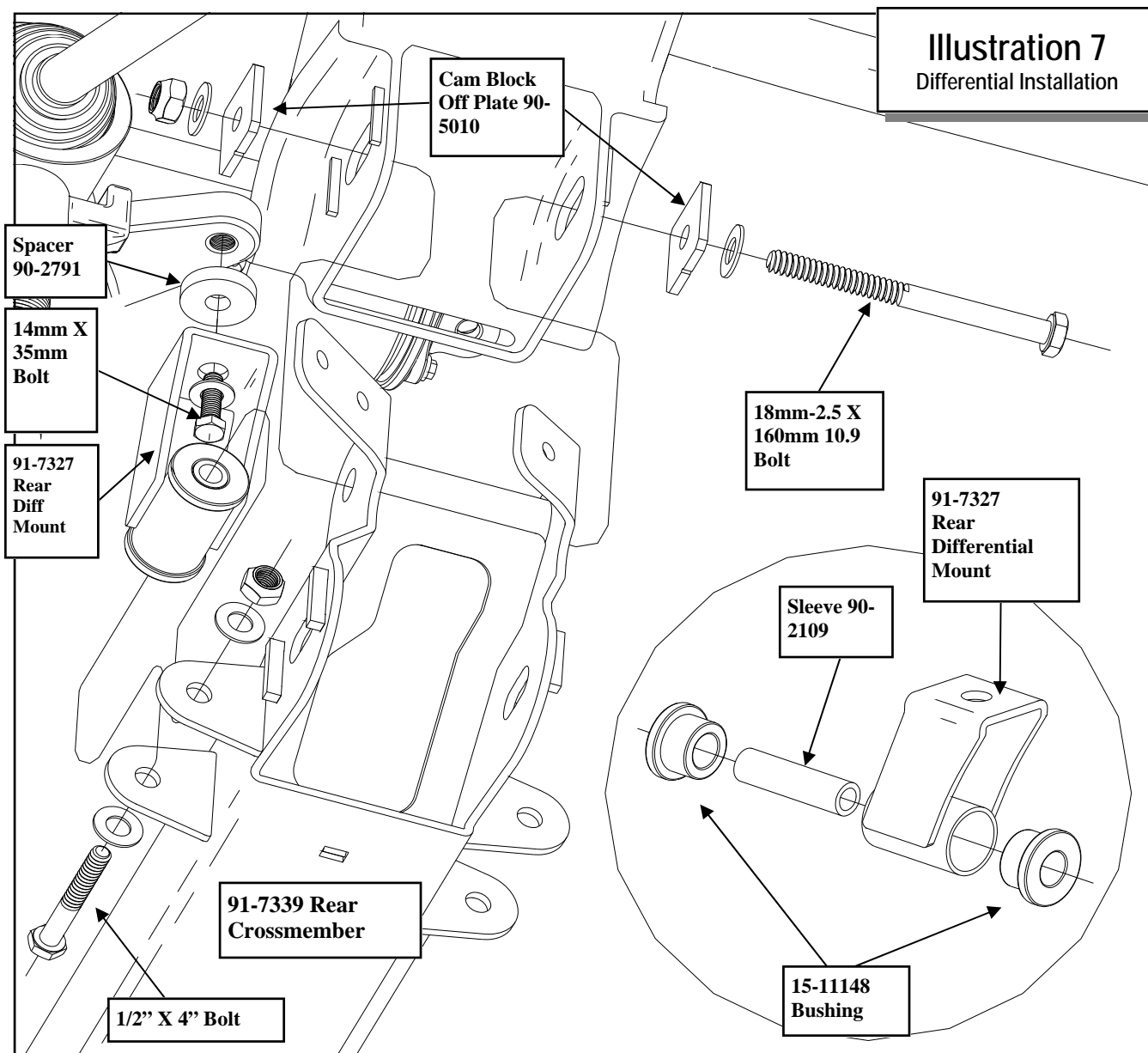

member mounting bolts to **275** ft./lbs. Torque the driver side **OE** diff bracket bolts to **95** ft./lbs and the **10mm** bolts to **50** ft./lbs. **DO NOT** over tighten the differential bolts. **DO NOT** torque the lower cam bolts until the vehicle is back on the ground.

48. **WITH THE STRUT SPACERS:** Scribe an index mark on the top of the **OE** coil spring to the upper strut mounting plate.

***CAUTION: The coil is under extreme pressure and severe bodily injury may occur if the coil spring is disassembled without using a coil spring compressor.***

49. Compress the coil spring on the strut assembly with a suitable coil spring compressor so that the coil spring has about **3/8"** play in the strut and remove the upper strut isolator retaining nut.

***NOTE: Do not use an impact gun to remove the retaining nut. It will damage the strut shaft.***

50. Remove the **OE** coil spring isolator from the upper strut mounting plate. Save the isolator for reuse.

***NOTE: Inspect the front shock assembly***

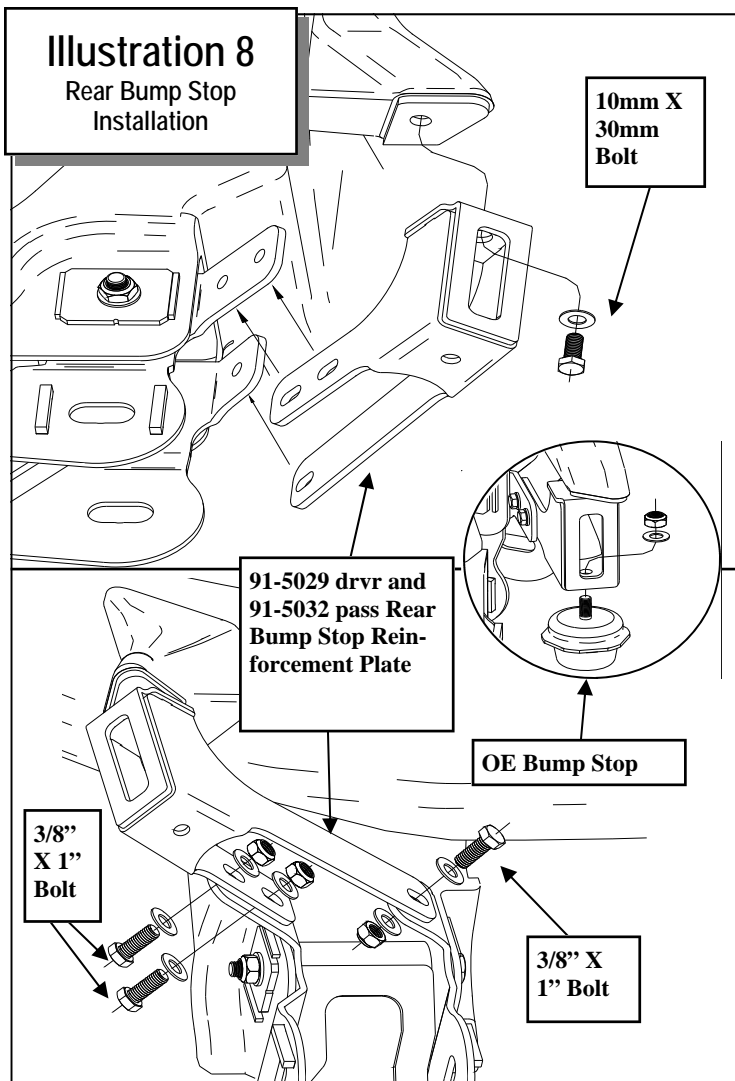

*for any damage or fluid leakage. Replace if necessary.*

51. Carefully remove the coil spring from the strut.
52. Using a utility knife cut the protective boot off of the strut assembly. Discard the boot.
53. Reinstall the compressed coil spring onto the strut assembly using the reference marks as a guide.
54. Install the supplied 1 1/4" coil spring spacer (91-4178), the OE spring isolator and the upper strut mounting plate onto the strut assembly. See ILLUSTRATION 9a.
55. Re-attach the upper strut mount plate using the OE hardware. Torque the upper strut

mounting plate retaining nut to 20 ft./lbs. See ILLUSTRATION 9a.

56. Decompress the coil spring on the strut assembly. Make sure that the spring is seated correctly into the strut assembly and aligned with the previously scribed index mark on the upper strut mounting plate.
57. Attach the new strut spacer (91-8170 Driver and 91-8172 Pass) to the top of the shock using the OE hardware. Torque to 47 ft./lbs. Fit the strut assembly and spacer into the stock mounting locations. Fasten using the supplied hardware on the top from hardware pack (90-6610) torque to 45-50 ft./lbs. See ILLUSTRATION 9b.

*NOTE: Drill out the upper strut mounting holes in the frame to 1/2".*

*NOTE: Be sure that the notch in the strut spacer (91-2795 Driver and 91-2802 Pass) is facing to the outside of the vehicle.*

58. Install the OE bolt through the lower strut mount and a-arm. Torque to 150 ft./lbs. See ILLUSTRATION 9b.
59. Work on one side of the vehicle at a time.
60. Transfer rear dust seal out of the OE knuckles onto the new Pro Comp knuckles (90-4333 driver and 90-4334 pass).

*NOTE: The factory backing plates will be reused.*

61. Clean and grind the paint off of the upper and lower lip of the steering stop on the lower ball joint bracket. Clamp the steering stop extension plates (96-3399 pass and 96-3400 driver) into place on the OE steering stop with the stamped numbers up. Be sure that the back edge of the new steering stop is flush with the OE steering stop. Place wet rags over the lower ball joint to protect from welding sparks. See ILLUSTRATION 10.

*NOTE: The front of the steering stop will not sit flush.*

62. Weld a bead along the top and bottom of the extension plates to secure it to the lower ball joint bracket. See ILLUSTRATION 10.



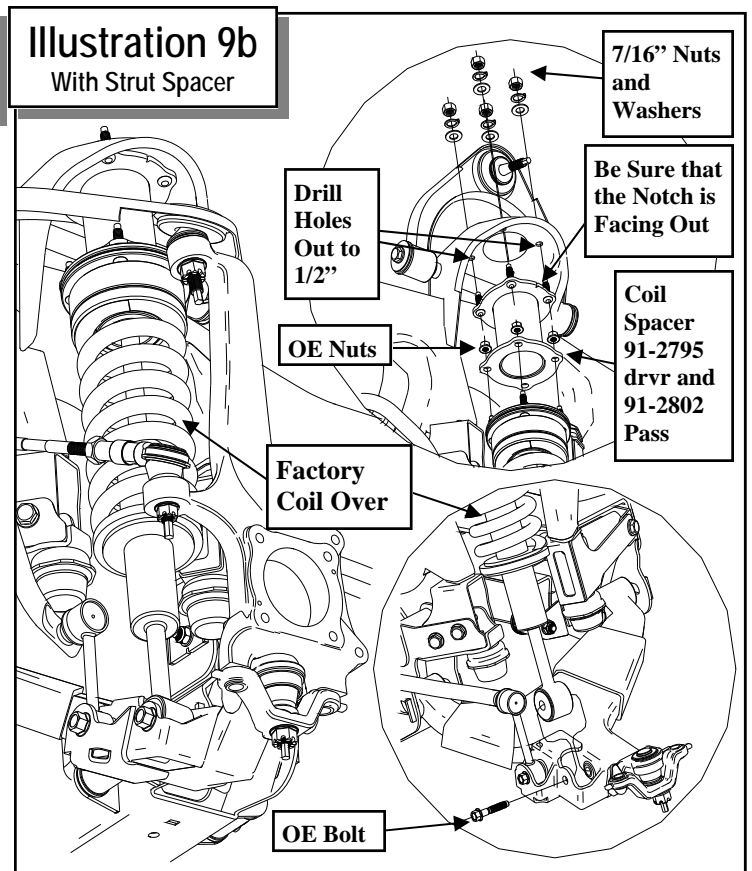
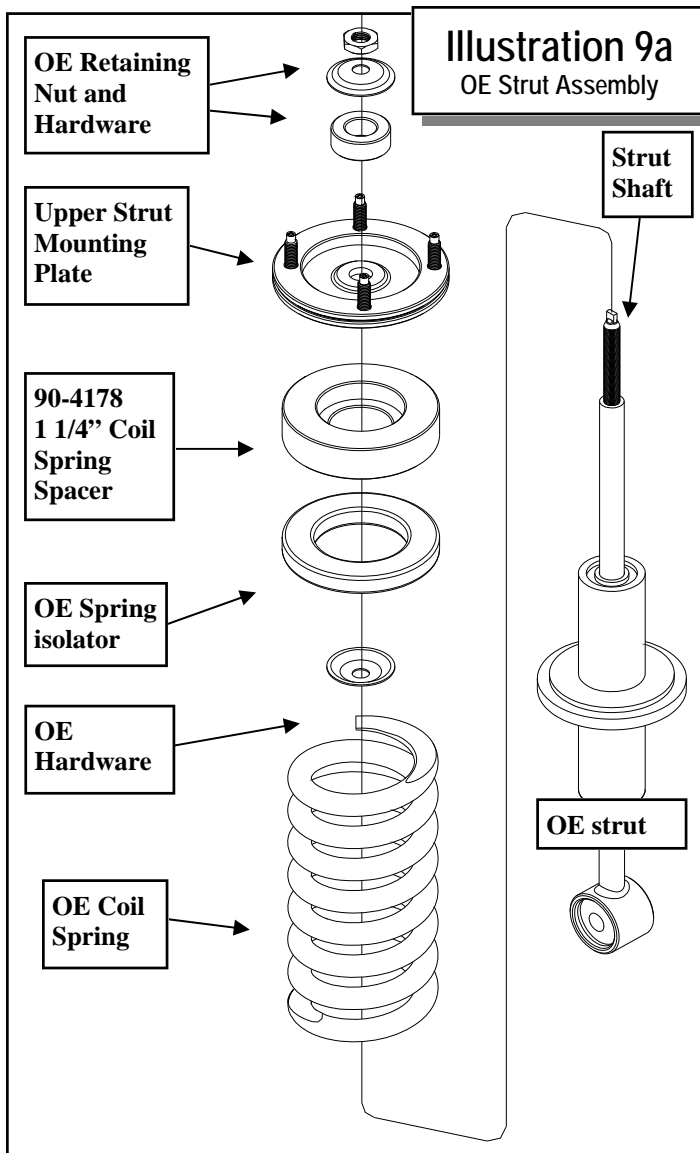

bracket using the (2) supplied **18mm-2.5 X 70mm 10.9** mounting bolts. Apply thread locking compound to the bolts. Torque the bolts to **230** ft./lbs.

63. After welding on the steering stop extension plates, clean the area thoroughly and paint the exposed metal with a good quality paint.

**NOTE: If you do not have access to a welder at this time the extension plates can be welded on at the completion of this installation or lower ball joint bracket can be removed and taken to a qualified welding shop.**

64. Support the lower A-arms and position the new knuckle (**90-4333 drv'r** and **90-4334 pass**) in place. Slide the CV axle through the knuckle from the rear and attach the knuckle to the upper ball joint. Torque to **67** ft./lbs. Install a new cotter pin from pack (**90-6623**).

65. Secure the knuckle to the lower ball joint

66. On both sides of the vehicle, install the **OE** hub and the **OE** backing plate onto the CV axles and into new Pro Comp knuckles. **IMPORTANT!: The OE backing plates MUST be installed behind the hubs. Failure to do so could prohibit the proper function of the magnetic pickup in the hub.** Tighten all the **OE** hardware carefully. Be sure to follow the factory assembly procedures and torque the (4) wheel hub mounting bolts to **75-85** ft./lbs.

**NOTE: Be sure to transfer the O-ring with the hub assembly.**

67. Attach the previously removed **OE** retaining nut to the end of the CV shaft. Torque to **275** ft./lbs. Install a new cotter pin from pack (**90-6623**) and reattach the dust cap.

68. Install the front rotors on to the front hubs.

69. Reinstall the brake calipers to the new

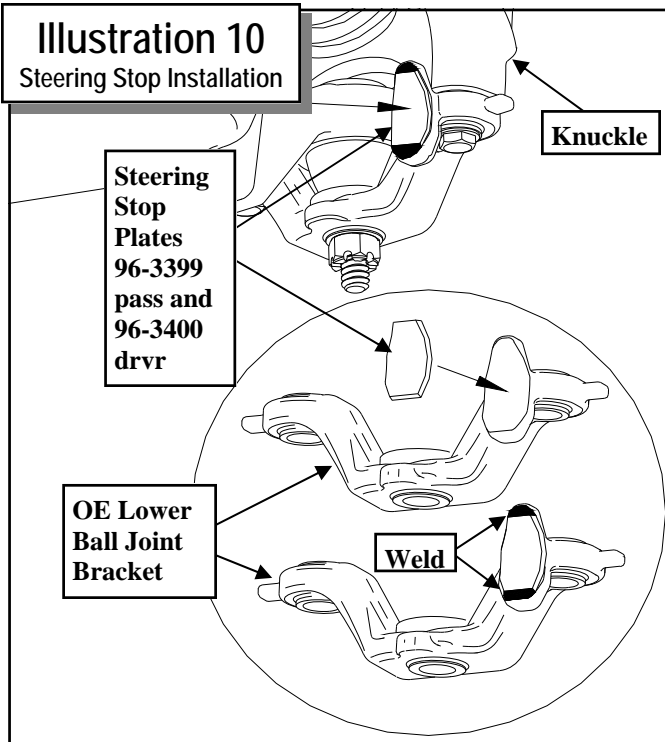

knuckle using the previously removed OE bolts. Torque to **75-85** ft./lbs.

**NOTE:** *It may be necessary to carefully pull down the factory metal lines to provide an adequate amount of slack. DO NOT kink the lines.*

70. Bolt the anti-lock brake wiring sensor to the hub. Reroute the ABS line and secure the line to the threaded hole on the back of the new knuckle using the supplied Adel clamp and OE ABS wire retaining bolt.
71. The driver side tie rod end and the passenger side tie rod end need to be exchanged to provide adequate tire clearance.
72. On driver side, loosen the lock nut and remove

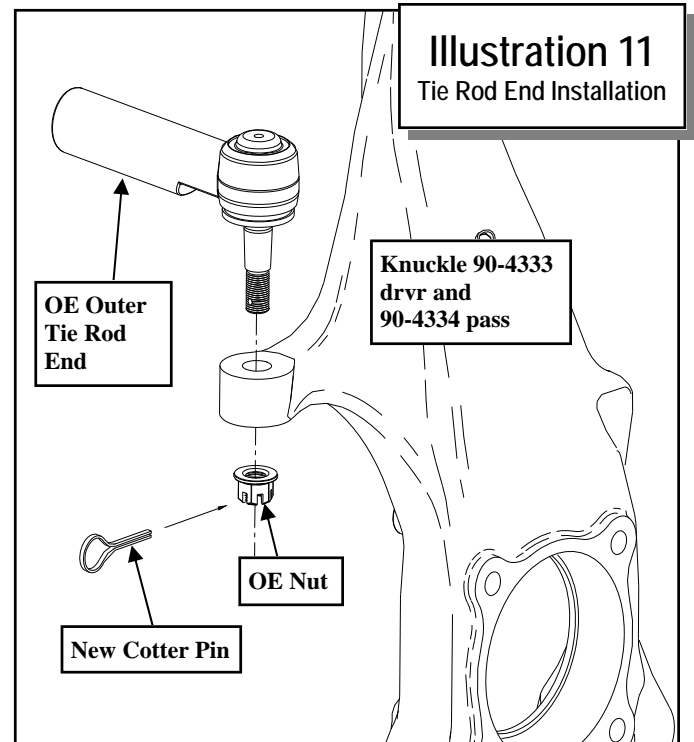
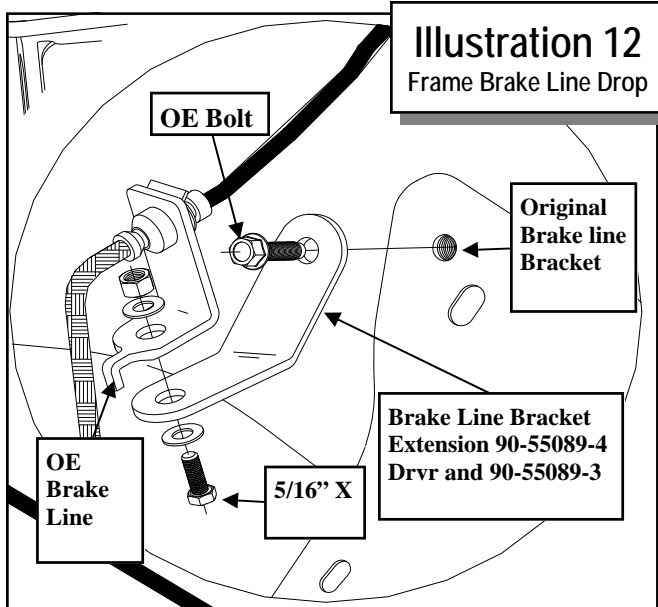

the tie rod end. Be sure to hold the outer tie rod end with a wrench to avoid hyper extending the tie rod joint. Repeat step on the passenger side.

73. The inner and outer tie rod ends, on both sides, need to be shortened by **1/4"**. Measure in **1/4"** from the end of the inner and outer tie rods and scribe a line. Using a suitable cutting tool, (cutoff wheel, Sawz-all, etc.) cut the end along the previously marked line. Be sure the cut is made straight and square or else the jam nut will not hold it's torque properly.
74. Install the previously removed driver side tie rod end on to the passenger side. Thread the tie rod on until it is in it's original location on the steering rack

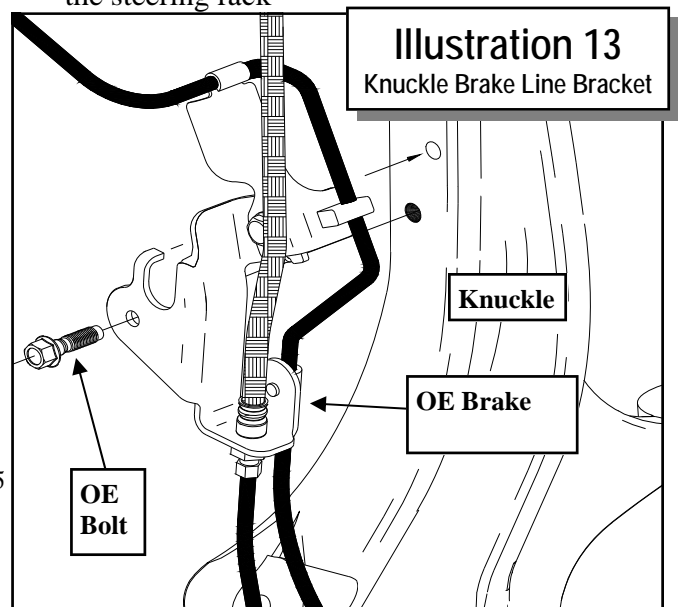

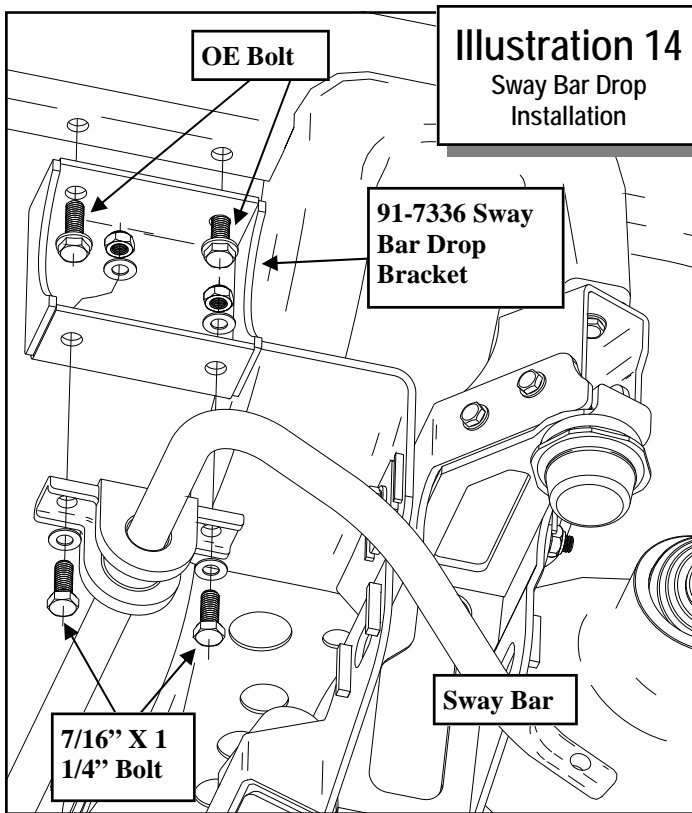

**Illustration 14**  
Sway Bar Drop  
Installation

bracket to the new knuckle using the **OE** bolt. See ILLUSTRATION 13.

shaft with the stud facing down.

75. Install the previously removed passenger side tie rod end on to the driver side. Thread the tie rod on until it is in its original location on the steering rack shaft with the stud facing down.
76. Insert from the top and secure the tie rod end to the knuckle and torque to **67** ft./lbs. Install a new cotter pins from pack (**90-6623**). See ILLUSTRATION 11.
77. Install the front brake line drop brackets (**55089-3** *drv*r and **55089-4** *pass*), with the short side up, to the original brake line mounting hole in the frame. Secure using the previously removed **OE** bolt. See ILLUSTRATION 12.
78. Bolt the brake line bracket to the new drop bracket using the supplied **5/16" X 1"** bolts and hardware.  
**NOTE: It may be necessary to carefully bend the metal brake line to provide adequate slack for its new position.**
79. Reattach the upper **OE** knuckle brake line

80. Install the sway bar drop brackets (**91-7336**) to the original sway bar mounting holes in the frame, with the offset facing toward the front of the vehicle, using the **OE** bolts. Torque to **55** ft./lbs. See ILLUSTRATION 14.
81. Reinstall the sway bar to the new sway bar drop brackets (**91-7336**) using the supplied **7/16" X 1 1/4"** bolts and hardware. Leave hardware loose at this time. See ILLUSTRATION 14.
82. Reattach the **OE** sway bar end links to the lower A-arm using the **OE** hardware.
83. Torque the sway bar mounting hardware according to the chart on page **21**. Torque the sway bar end link to lower A-arm bolts to **85** ft./lbs.
84. On both sides of the vehicle, check the routing of the brake lines and the ABS wire harnesses. There must be no pinching, rubbing, or stretching of either component. Use zip ties to secure these items to the steering components. At full droop, cycle the steering from lock to lock while observing the reaction of these components. Reposition them if needed.
85. Reconnect the negative battery cable to the battery.
86. Reinstall the wheels and lower the vehicle to the ground. Torque the lug nuts according to the wheel manufacturers recommendations.
87. With the truck on the ground center the lower A-arm cam bolts and torque to **145** ft./lbs.
88. Center the steering wheel and lock it in place. Set the toe by adjusting the tie rod ends properly.

**NOTE: The tie rod ends may need to be trimmed if the recommended toe-in specification cannot be achieved.**

**IMPORTANT!: If the steering wheel is not centered properly it will trigger the anti-lock brake and traction control warning lights.**



89. Lock the outer tie rod ends by tightening the **OE** jam nuts.
90. Recheck all hardware for proper installation and torque at this time.

***IMPORTANT! BE SURE TO BRING THE VEHICLE IMMEDIATELY TO A REPUTABLE ALIGNMENT SHOP TO BE ALIGNED!***

**NOTES:**

- ⇒ **On completion of the installation, have the suspension and headlights re-aligned.**
- ⇒ **After 100 miles recheck for proper torque on all newly installed hardware.**
- ⇒ **Recheck all hardware for tightness after off road use.**

# Rear Installation:

1. Block the front tires and raise the rear of the vehicle. Support the frame with jack stands forward of the rear springs.
2. Remove the rear wheels.
3. Remove the shocks on both sides of the vehicle. It may be necessary that you slightly raise the axle to unload the shocks for removal.
4. Unclip the ABS line from the charcoal canister bracket. Leave the zip ties in place.  
*NOTE: It may be necessary to carefully bend the bracket down.*
5. Unbolt the emergency brake cable bracket from the rear axle and install the E-brake cable extension bracket (90-1083). Use the OE bolt to secure the drop bracket to the rear axle.
6. Reconnect the E-brake cable bracket to the extension bracket using the supplied 5/16" X 1" bolt and hardware.

*NOTE: The tabs on the OE E-brake bracket will need to be bent flat before reinstallation.*

7. Unclip the OE brake lines from the rear brake line retaining bracket on the frame. Save the clips for reinstallation. See ILLUSTRATION 15.
8. Using a suitable tool, (abrasive cutoff wheel, etc.) cut a notch in the frame bracket that retains the rear brake lines so the lines can be removed from the bracket. See ILLUSTRATION 15.

*NOTE: Be sure not to damage the brake line while cutting and removing the line.*

9. Install the rear axle brake line relocation bracket (90-5035) to the existing frame bracket using the supplied 3/8" X 1" bolts and hardware from pack (90-6604). See ILLUSTRATION 15.

*NOTE: The larger diameter washer goes on top of the frame bracket.*

10. Secure the brake lines to the drop brackets using the previously removed OE clips. See ILLUSTRATION 15.

*NOTE: Be sure that the metal brake lines are not rubbing against the frame or each other. Carefully bend or reroute the metal lines if necessary.*

11. Work on one side of the vehicle at a time.
12. Support the rear axle with a floor jack and remove the U-bolts on the driver side. Loosen the U-bolts on the passenger side and carefully lower the rear axle.

*NOTE: Be sure not to over extend the rear brake line and rear axle vent line.*

13. Use C-clamps to hold the leaves of the rear leaf spring together and remove spring center bolt.
14. Remove the factory overload spring and. Insert the add-a-leaf (13129). See ILLUSTRATION 16.

*NOTE: The factory installed roll pin will need to be removed from the overload*

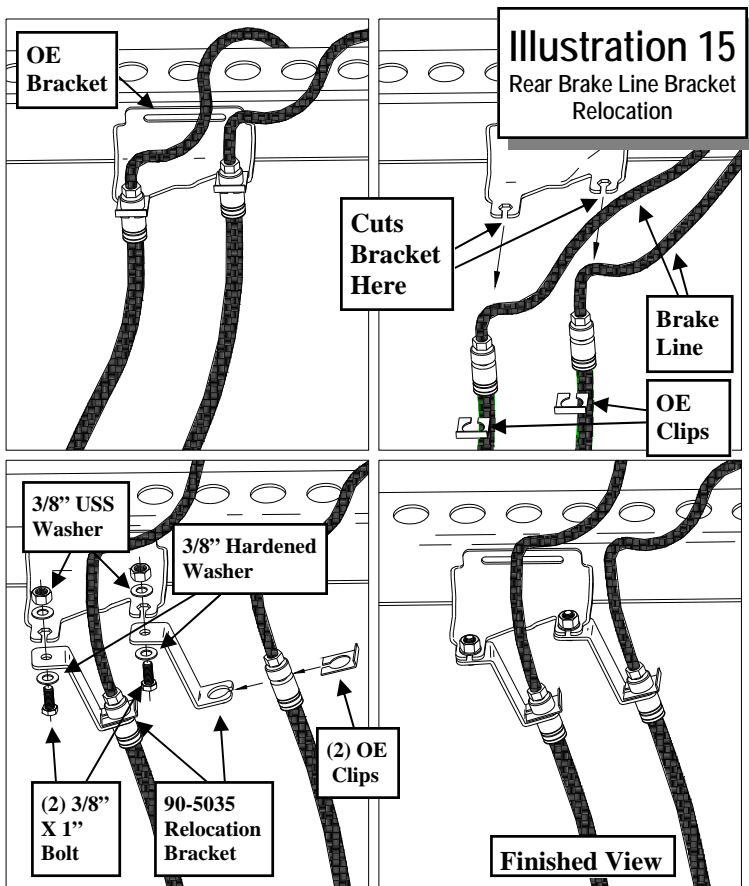

*spring before the spring is reassembled.*

- Using the C-clamps, bolt the leaf pack back together using the supplied center bolt (97-380) with the head of the bolt facing down. See ILLUSTRATION 16.

**NOTE:** *It will be necessary to cut the center pin bolt to allow for reattachment of the rear OE bump stop.*

- Install the lift block (95-102), with the pin offset toward the front of the vehicle, making sure the pins are fitted into the holes on the

spring perch. Use your floor jack to raise the axle to the spring making sure the pin on the leaf spring fit into the holes on the new lift block. See ILLUSTRATION 16.

- Secure the assembly with the U-bolts (13-90126) and new hi-nuts and washers from hardware pack (20-65302). Do not torque the U-bolts at this time. See ILLUSTRATION 16.

**NOTE:** *Make sure the block sits flush on the axle perch.*

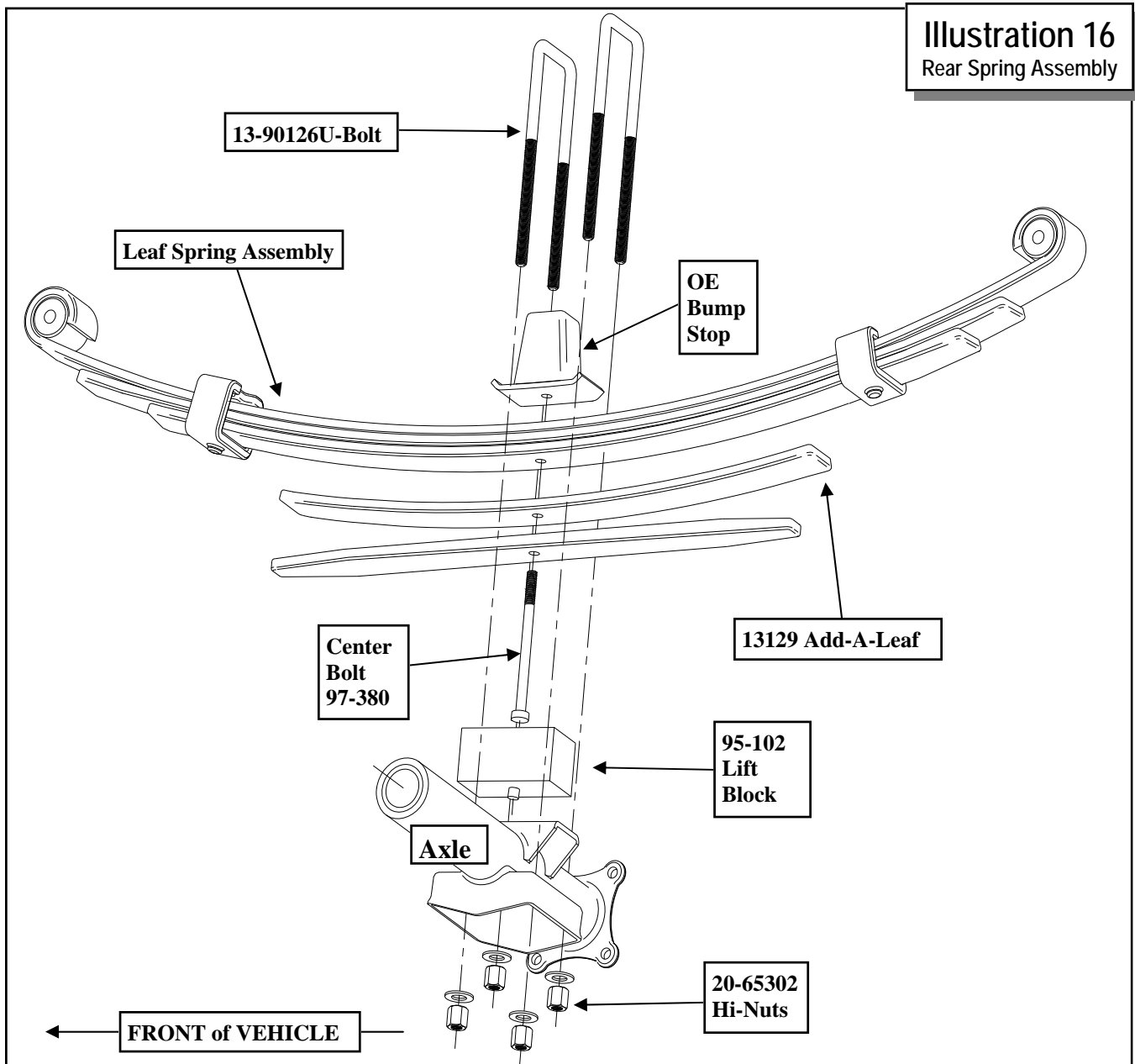

18. Install the provided spring plate clamps over the ends of the spring pack (**98-00250-1**) to secure the add-a-leaf in place.
19. Repeat the installation on the other side of the vehicle.
20. When the installation of the remaining side is complete, torque the **U-bolts** to **105-110** ft./lbs.
21. Install the new Pro Comp shock absorbers (**ES927591**) using the previously removed **OE** lower bolts. Torque this hardware to **74** ft./lbs.
22. Remove the (**2**) bolts that secure the carrier bearing to the frame. Lower the bearing and install the **1/2"** thick shims from pack (**90-6613**) as a start. Additional shims may be required to eliminate the vibration. Bolt the carrier bearing back to the frame using the previously removed **OE** bolts or the supplied **10mm-1.25 X 50mm** bolts and washers, depending on the amount of shims used.  
***NOTE: Installation of the 1/2" shims is only a starting point. Only by driving the vehicle and adding or removing shims can the off the line vibration be eliminated.***
23. Carefully reroute and re-clip the ABS lines in order to provide adequate slack.
24. Check all hardware at this time to ensure that everything is tight. Check for adequate clearance on all repositioned brake lines and emergency brake cables. Make sure you check with the suspension fully extended, and compressed.
25. Reinstall the wheels and lower the vehicle to the ground. Torque the lug nuts according to the wheel manufacturers recommendations.

**NOTES:**

- ⇒ **On completion of the installation, have the suspension and headlights re-aligned.**
- ⇒ **After 100 miles recheck for proper torque on all newly installed hardware.**
- ⇒ **Recheck all hardware for tightness after off road use.**

## Revisions Page:

**4.19.12:** Added steps 72 through 77 concerning the swapping of outer tie rod ends drvrr for passenger.

**5.7.12:** Added Hardware pack 90-6615 to BOM box-3. Added corresponding steps to rear install instructions and illustration #15.

**12.19.12:** Deleted step #24. Added a note after step #88 that the tie rod ends may need to be trimmed if toe-in specs cannot be achieved.

**3.17.15:** Updated step 72 to include pass side also. Updated step 73 with tie rod trimming instructions.

Use this only as a guide for hardware without a called out torque specification in the instruction manual.

<b>Decimal System</b>				<b>Metric System</b>		
All Torques in Ft. Lbs. Maximums						
Bolt Size	Grade 5	Grade 8	Bolt Size	Class 9.8	Class 10.9	Class 12.9
5/16	15	20	M6	5	9	12
3/8	30	45	M8	18	23	27
7/16	45	60	M10	32	45	50
1/2	65	90	M12	55	75	90
9/16	95	130	M14	85	120	145
5/8	135	175	M16	130	165	210
3/4	185	280	M18	170	240	290

 <p>1/2-13x1.75 HHCS      <b>Grade 5    Grade 8</b> (No. of Marks + 2)</p> <p>D    T    L    X</p> <p>G = Grade (Bolt Strength) D = Nominal Diameter (Inches) T = Thread Count (Threads per Inch) L = Length (Inches) X = Description (Hex Head Cap Screw)</p>	 <p>M12-1.25x50 HHCS</p> <p>D    T    L    X</p> <p>P = Property Class (Bolt Strength) D = Nominal Diameter (Millimeters) T = Thread Pitch (Thread Width, mm) L = Length (Millimeters) X = Description (Hex Head Cap Screw)</p>
---	---

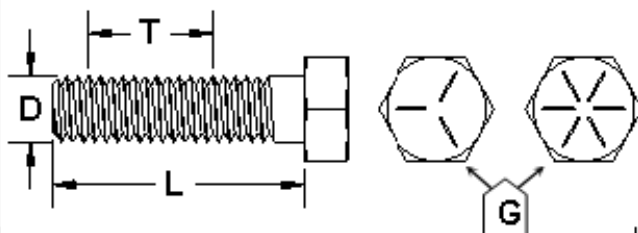
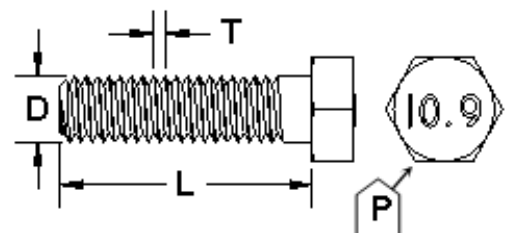

## The PRO COMP PROMISE WARRANTY

At Pro Comp, we know you have many choices when selecting products to personalize your vehicle. You should demand nothing but the highest quality available and have total confidence that the products you selected are the best in the industry. It is for these reasons that Pro Comp Suspension products are backed by the best warranty in the industry...the Pro Comp Promise!

Pro Comp promises that its products will last a lifetime or we will replace it free of charge. It's that simple! Because of our commitment to quality and manufacturing excellence, we are able to stand behind our products. FOREVER.

It is Pro Comp's Promise that if one of our suspension products breaks not due to misuse, neglect or vandalism, we will replace it. Whether you are the original purchaser or not, you can be assured that we will make it right. The Pro Comp Promise covers all suspension products including shocks and steering stabilizers. Buy Pro Comp Suspension today and enjoy it for the rest of your life!

That's our Pro Comp Promise!

## Notice to Owner, Operator, Dealer and Installer:

Vehicles that have been enhanced for off-road performance often have unique handling characteristics due to the higher center of gravity and larger tires. This vehicle may handle, react and stop differently than many passenger cars or unmodified vehicles, both on and off-road. You must drive your vehicle safely! Extreme care should always be taken to prevent vehicle rollover or loss of control, which can result in serious injury or even death. Always avoid sudden sharp turns or abrupt maneuvers and allow more time and distance for braking! Pro Comp reminds you to fasten your seat belts at all times and reduce speed! We will gladly answer any questions concerning the design, function, maintenance and correct use of our products.

Please make sure that the Dealer / Installer explains and delivers all warning notices, warranty forms and instruction sheets included with Pro Comp product.

Warranty and Return Policy:

Pro Comp warrants its full line of products to be free from defects in workmanship and materials for the life of the product. Pro Comp's obligation under this warranty is limited to repair or replacement, at Pro Comp's option, of the defective product. Any and all costs of removal, installation, freight or incidental or consequential damages are expressly excluded from this warranty. Pro Comp is not responsible for damages and / or warranty of other vehicle parts related or non-related to the installation of Pro Comp product. A consumer who makes the decision to modify his vehicle with aftermarket components of any kind will assume all risk and responsibility for potential damages incurred as a result of their chosen modifications. Warranty coverage does not include consumer opinions regarding ride comfort, fitment and design. Warranty claims can be made directly with Pro Comp or at any factory authorized Pro Comp dealer.

IMPORTANT! To validate the warranty on this purchase please be sure to mail in the warranty card.

Claims not covered under warranty

\* Parts subject to normal wear; this includes bushings, bump stops, ball joints, tie rod ends and heim joints.

\* Finish after 90 days.

\* Damage caused as a result of not following recommendations or requirements called out in the installation manuals.

Pro Comp MX Series coil-over shocks are considered a serviceable shock with a one-year warranty against leakage only. Rebuild service and replacement parts will be available and sold separately by Pro Comp. Contact Pro Comp for specific service charges. Pro Comp accepts no responsibility for any altered product, improper installation, lack of or improper maintenance or improper use of our products.