



PRO COMP SUSPENSION

Suspension Systems that Work!

Part #
55717BRH/55717BMXRH
2007-2013 Jeep Wrangler
4WD 2 Door & 4 Door JK
Stage 1
4" Lift Kit

This document contains very important information that includes warranty information and instructions for resolving problems you may encounter. Please keep it in the vehicle as a permanent record.

Part #	Description	Qty	Illus.	Page
90-4149	REAR BUMPSTOP EXTENSIONS	2	4	8
90-6536	HARDWARE PACK: Rear Bump Stop Lock Plate	1	-	-
70-0501751800	1/2" X 1 3/4" GR. 8 HEX BOLT	2	4	8
72-050100812	1/2" NYLOCK NUT	2	4	8
73-05000830	1/2" SAE FLAT WASHER	2	4	8
90-6525	HARDWARE PACK: Brake Line Drop	1	-	-
70-0251001800	1/4"-20 X 1" GR. 8 HEX BOLT	4	-	-
72-025100816	1/4"-20 STOVER NUT	4	-	-
73-02500830	1/4"-20 SAE FLAT WASHER	8	-	-
90-6605	HARDWARE PACK: Brake Line/Track Bar/Bump Stop	1	-	-
90-3719	REAR BUMPSTOP LOCK PLATE	2	4	8
90-1539	BRAKE LINE DROP	4	-	-
90-2650	REAR TRACK BAR SPACER	1	2	7
90-5490	REAR TRACK BAR BRACKET	1	2	7
90-6528	HARDWARE PACK: Rear Track Bar Bracket	1	-	-
70-0563251800	9/16" X 3 1/4" GR. 8 HEX BOLT	1	2	7
72-056100816	9/16" STOVER NUT	1	2	7
73-05600830	9/16" SAE FLAT WASHER	2	2	7
70-0371001800	3/8" X 1" GR. 8 HEX BOLT	2	2	7
70-0371251800	3/8" X 1 1/4" GR. 8 HEX BOLT	2	3	7
72-037100816	3/8" STOVER NUT	4	2	7
73-03700830	3/8" SAE FLAT WASHER	8	2	7
90-6529	HARDWARE PACK: Jeep Cam Kit	1	-	-
73-01410940	14mm FLAT WASHER	1	2	7
72-01415008812	14mm- 1.5 NUT	1	2	7
90-3245	NOTCHED CAM	1	2	7
90-3718	CAM BOLT	1	2	7
90-6526	HARDWARE PACK: Sway Bar	1	-	-
73-01210940	12mm FLAT WASHER	8	-	-
72-01215008812	12mm- 1.75 STOVER NUT	4	-	-
71-120601751000	12mm- 1.75 X 60mm 10.9 HEX BOLT	4	-	-
90-6042	HARDWARE PACK: Sway Bar	2	-	-
45359	5/8" RUBBER HOURGLASS BUSHING	4	1	5
60859	SLEEVE	4	1	5
90-8012	JEEP SWAY BAR END LINK: Rear	2	-	-
90-2008	JEEP SWAY BAR END LINK: Front	2	1	5

Part #	Description	Qty	Illus.	Page
90-6537	HARDWARE PACK: Front X-Member Spacer	1	-	-
90-2207	1/2" Spacer	2	-	-
90-6538	HARDWARE PACK: Front X-Member Spacer	1	-	-
73-01210930	12mm FLAT WASHER	2	-	-
71-120501051000	12mm- 1.5 X 50mm 10.9 HEX BOLT	2	-	-
15-11309	FRONT BUMPSTOP	2	-	-
90-5494	TRACK BAR BRACKET BRACE	1	3	7
90-6622	HARDWARE PACK: Track Bar Brace	1	-	-
70-0371001800	3/8" X 1" Hex Bolt Gr. 8	3	3	7
72-037100816	3/8" Stover Nut	3	3	7
73-03700034	3/8" Flat Washer	6	-	-

FOLLOWING PARTS ARE USED IN CONJUNCTION WITH THIS KIT. THEY ARE PACKAGED AND MUST BE ORDERED SEPARATELY.

55397	JEEP FRONT COIL SPRING	1	-	-
55217	JEEP REAR COIL SPRING (2 Door Vehicles)	1	-	-
55207	JEEP REAR COIL SPRING (4 Door Vehicles)	1	-	-
926511	ES9000 SERIES FRONT SHOCK	2	-	-
926501	ES9000 SERIES REAR SHOCK	2	-	-
<i>OR</i>				
MX6013	MX-6 SERIES FRONT SHOCK	2	-	-
MX6151	MX-6 SERIES REAR SHOCK	2	-	-

Introduction:

- ◆ **This installation requires a professional mechanic!**
- ◆ We recommend that you have access to a factory service manual for your vehicle to assist in the disassembly and reassembly of your vehicle. It contains a wealth of detailed information.
- ◆ Prior to installation, carefully inspect the vehicle's steering and driveline systems paying close attention to the tie rod ends, ball joints, wheel bearing preload, pitman and idler arm. Additionally, check steering-to-frame and suspension-to-frame attaching points for stress cracks. The overall vehicle must be in excellent working condition. Repair or replace all worn or damaged parts!
- ◆ Read the instructions carefully and study the illustrations before attempting installation! You may save yourself a lot of extra work.
- ◆ Check the parts and hardware against the parts list to assure that your kit is complete. Separating parts according to the areas where they will be used and placing the hardware with the brackets before you begin will save installation time.
- ◆ Check the special equipment list and ensure the availability of these tools.
- ◆ Secure and properly block vehicle prior to beginning installation.
- ◆ **ALWAYS** wear safety glasses when using power tools or working under the vehicle!
- ◆ Use caution when cutting is required under the vehicle. The factory undercoating is flammable. Take appropriate precautions. Have a fire extinguisher close at hand.
- ◆ Foot pound torque readings are listed on the Torque Specifications chart at the end of the instructions. These are to be used unless specifically directed otherwise. Apply thread lock retaining compound where specified.
- ◆ ***Please note that while every effort is made to ensure that the installation of your Pro Comp lift kit is a positive experience, variations in construction and assembly in the vehicle manufacturing process will virtually ensure that some parts may seem difficult to install. Additionally, the current trend in manufacturing of vehicles results in a frame that is highly flexible and may shift slightly on disassembly prior to installation. The use of pry bars and tapered punches for alignment is considered normal and usually does not indicate a faulty product. However, if you are uncertain about some aspect of the installation process, please feel free to call our tech support department at the number listed on the cover page. We do not recommend that you modify the Pro Comp parts in any way as this will void any warranty expressed or implied by the Pro Comp Suspension company.***

PLEASE NOTE:

Due to differences in manufacturing, dimensions and inflated measurements, tire and wheel combinations should be test fit prior to installation. Tire and wheel choice is crucial in assuring proper fit, performance, and the safety of your Pro Comp equipped vehicle. For this application, we recommend a 17" wheel not to exceed 10" in width with a maximum backspacing of 5" must be used. Additionally, quality tire of radial design, not exceeding 35" tall X 12.5" wide is also recommended. Please note that the use of a 35" X 12.5" tire may require fender modification. Violation of these recommendations will not be endorsed as acceptable by Pro Comp Suspension and will void any and all warranties either written or implied.

FRONT INSTALLATION:

1. Position your vehicle on a smooth, flat, hard surface (i.e. concrete or asphalt). Block the rear tires and set the emergency brake.
2. Measure and record the distance from the center of each wheel to the top of its fender opening. Record below.

LF: _____ RF: _____

LR: _____ RR: _____

3. Place the vehicle in neutral. Place your floor jack under the front axle and raise the vehicle. Place jack stands under the frame rails and lower the frame onto the stands. Remove the jack and place the vehicle back in gear, set the emergency brake, and place blocks both in front and behind the rear wheels.
4. Unbolt and remove the transmission skid plate from the vehicle.
5. Unbolt and remove the front sway bar end links from the vehicle. Save the hardware for reuse.
6. Remove the shocks on both sides of the vehicle. It may be necessary that you slightly raise the axle to unload the shocks for re-

moval.

7. Unbolt the front track bar from the front axle mount and secure up and out of the work area. Save the hardware for reinstallation.
8. Unbolt the all the ABS mounting clips from the vehicle.
9. Unbolt the front brake line brackets from the vehicle.
10. Lower the front axle enough to remove the coil springs from the front spring pockets. Save the factory isolators for re-use.

NOTE: Be sure to support the axle while the springs and shocks are removed.

11. Remove the OE bump stops from the vehicle.
12. Install the front brake line drop (90-1539) into the original frame mounting hole using the previously removed OE bolt.
13. Secure the brake line to the supplied drop bracket (90-1539) using the supplied 1/4"-20 X 1" bolt and hardware.

14. Install the supplied bump stops (15-11309) into the OE bump stop mounting cup.

NOTE: To properly seat the newly installed bump stops, carefully lower the weight of the vehicle onto the bump stops.

15. Carefully lower the front axle to ease in the new front coil spring installation. Using the factory isolators install the Pro Comp coil springs (55397-2) into the spring buckets and raise the front axle into place. Make sure the front coil spring seats properly on the lower spring perch.

16. Assemble the front sway bar end links (90-2041) using the supplied bushings (45359) and sleeves (60859) from hardware pack (90-6042). See ILLUSTRATION 1.

17. Install the front sway bar end link (90-2008) into original mounting bracket on the axle using the OE hardware.

18. Bolt the remaining end of the sway bar end

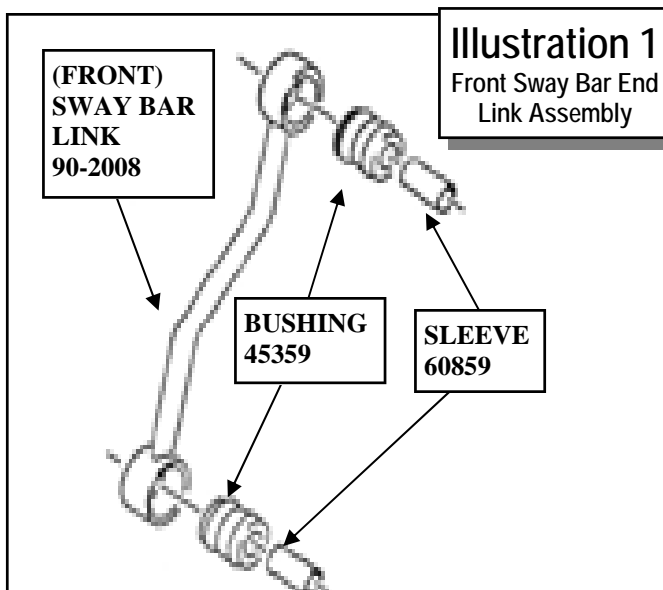

link to the front sway bar using the supplied **12mm X 60mm** bolt and hardware. Torque the **12mm** hardware according to the torque chart on page 10.

19. Reinstall the transmission skid plate using the supplied (2) **1/2"** spacers (**90-2207**) and **12mm-1.5 X 50mm** bolts in the frame rail mounting bolts only. Secure the remaining rear hole to the frame using the previously removed **OE** bolt. Torque the crossmember hardware according to the torque chart on page 9.
20. Install your new Pro Comp front shocks (**MX6013** or **ES9013 w/shaft end up**) using the **OE** hardware. Torque the upper mounting hardware to 17 ft./lbs. and the lower to 35 ft./lbs.
21. On both sides of the vehicle, check the routing of the brake lines and the ABS wire harnesses. There must be no pinching, rubbing, or stretching of either component. Use zip ties to secure these items to the steering components. At full droop, cycle the

steering from lock to lock while observing the reaction of these components. Reposition them if needed.

22. Reinstall the front wheels and lower the vehicle to the ground. Torque the lug nuts according to the wheel manufacturers recommendations.
23. Reinstall the **OE** front track bar to the axle mount using the previously removed **OE** hardware. Torque the track bar mounting bolt according to manufacturers specifications.

NOTES:

- ⇒ **On completion of the installation, have the suspension and headlights re-aligned.**
- ⇒ **After 100 miles recheck for proper torque on all newly installed hardware.**
- ⇒ **Recheck all hardware for tightness after off road use.**

REAR INSTALLATION:

1. Block the front tires and raise the rear of the vehicle. Support the frame with jack stands forward of the rear springs.
2. Remove the rear wheels.
3. Unbolt the rear track bar from the rear axle mount and secure up and out of the work area. Save the hardware for reinstallation.
4. Remove the shocks on both sides of the vehicle. It may be necessary that you slightly raise the axle to unload the shocks for removal.
5. Unbolt and remove the rear sway bar end links from the vehicle. Save the hardware for

reuse.

6. Lower the rear axle enough to remove the coil springs from the rear spring pockets. Save the factory isolators for re-use.
NOTE: Be sure to support the axle while the springs and shocks are removed.
7. Using a twisting motion remove the rear bump stops from the factory mounts.
8. Unbolt the rear brake line brackets from the vehicle.
9. Install the rear brake line drop (**90-1539**) into the original frame mounting hole using the previously removed **OE** bolt.

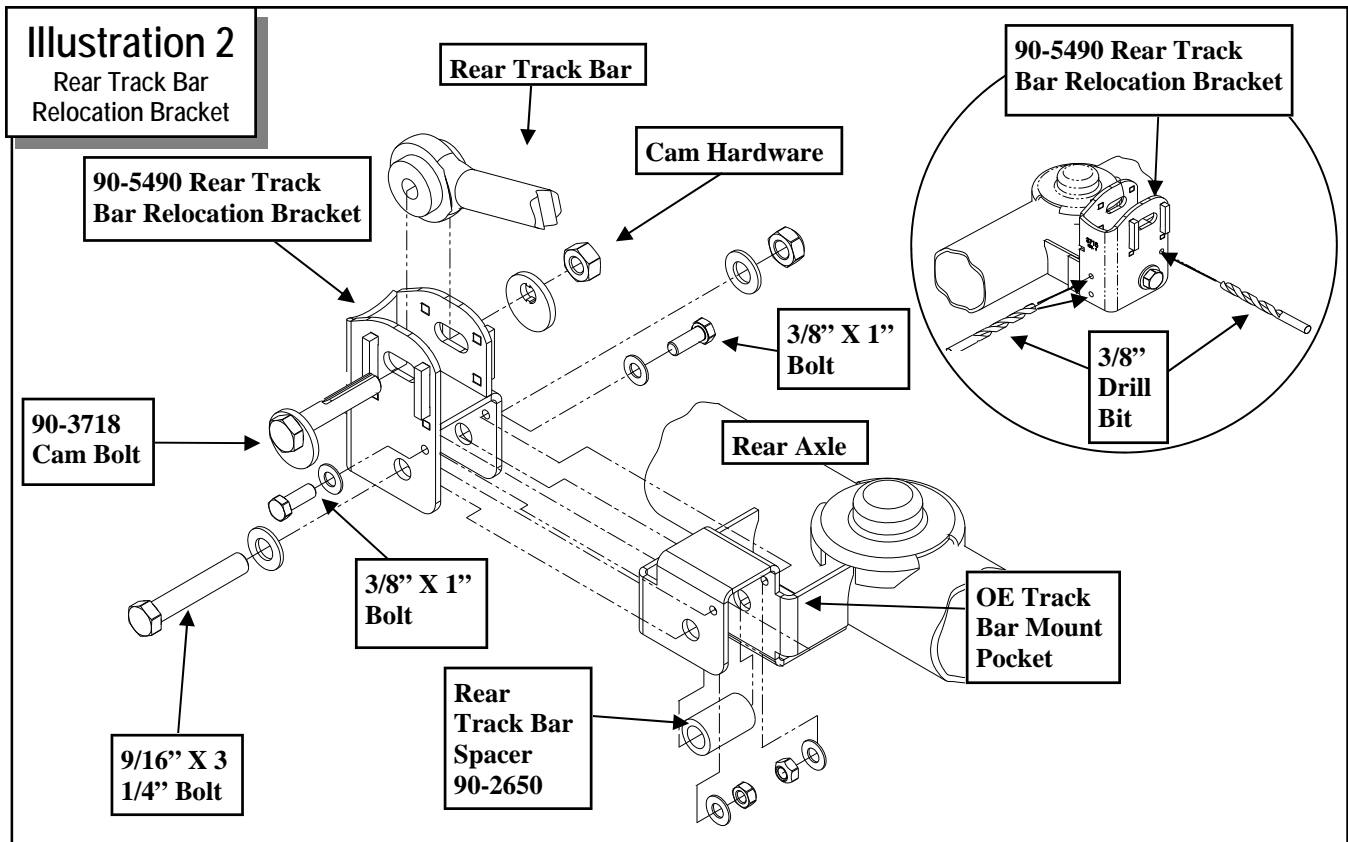

10. Install the rear track bar relocation bracket (**90-5490**) into the original track bar mounting pocket using the supplied **9/16" X 3 1/4"** bolt and supplied spacer (**90-2650**).
11. Using the relocation bracket as a guide drill the **1/4"** holes in the axle mounting pocket out to **3/8"**. See ILLUSTRATION 2.
12. Insert the (2) front **3/8" X 1"** bolt into the front and rear face of the track bar bracket to secure it to the rear axle. See ILLUSTRATION 2.
13. Raise the track bar bracket brace (**90-5494**) into position on the driver side of the rear axle. Secure the brace to the (2) existing holes in the rear axle shock mount using the (2) supplied **3/8" X 1"** bolt and hardware. See ILLUSTRATION 3.
14. Using the remaining top hole in the brace as a guide and mark the track bar bracket for drilling.
15. Center punch and drill the previously applied mark using a **3/8"** drill bit. See ILLUSTRATION 3.
16. Secure the brace to the track bar bracket using

the remaining (2) **3/8" X 1 1/4"** and (1) **3/8" X 1"** (top hole) bolts and hardware. See ILLUSTRATION 3.

17. Torque the **3/8"** and **9/16"** track bar hardware according to the torque chart on page 10.
18. Carefully lower the rear axle to ease in the

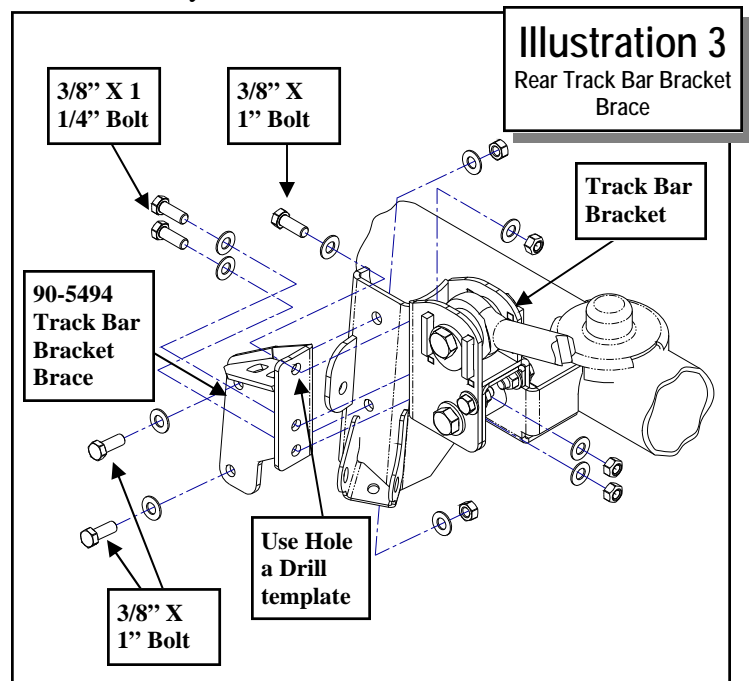

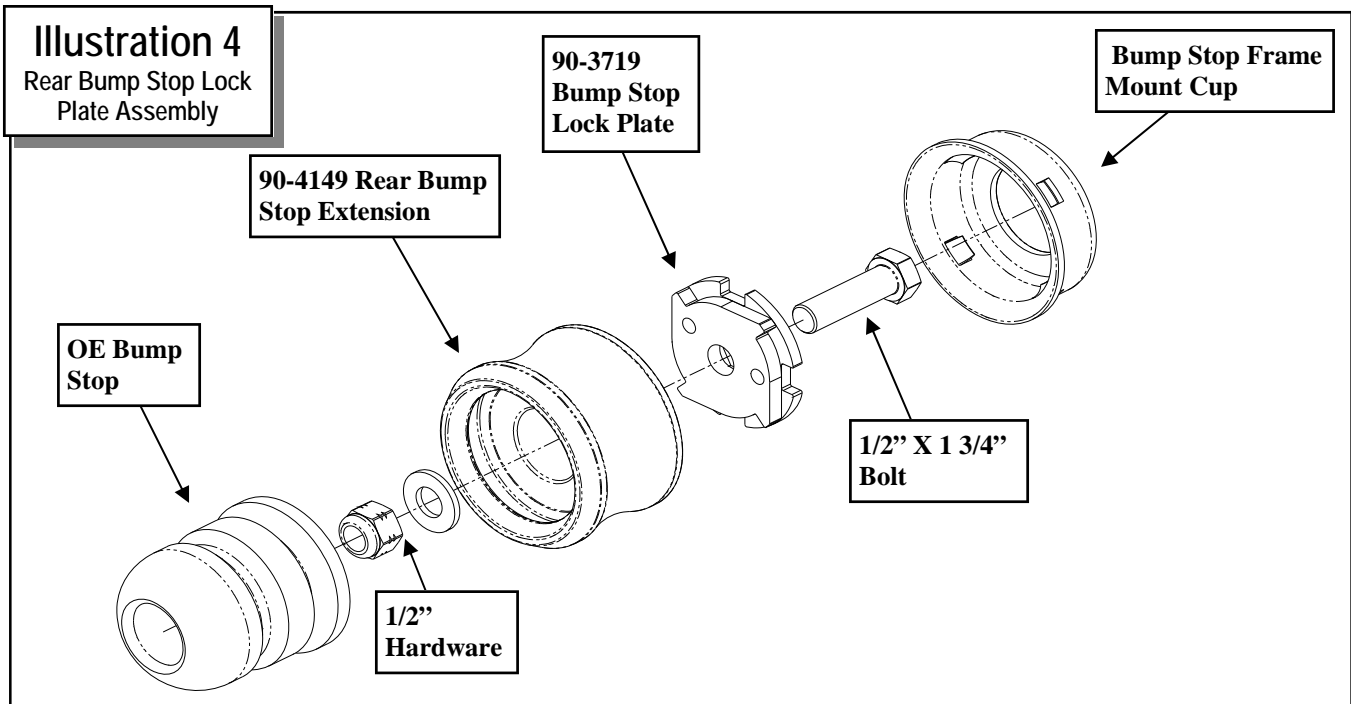

new rear coil spring installation. Using the factory isolators install the Pro Comp rear coil springs (**55217-2 two door or 55207-2 four door**) into the spring buckets and raise the rear axle into place. Make sure the coil spring seats properly on the lower spring perch.

NOTE: *Be sure to reinstall the factory isolators before raising the springs into place.*

19. Slide the **1/2" X 1 3/4"** Bolt through the center of the bump stop lock plate (**90-3719**). Install the lock plate assembly to the original bump stop frame mounting bracket. Secure using a **1/4** turn clockwise. See ILLUSTRATION 4.
20. Slide the rear bump stop extensions over the mounted lock plate assembly and secure using the supplied **1/2"** hardware from pack (**90-6536**). Torque hardware to 35 ft./lbs. See ILLUSTRATION 4.
21. Reinstall the **OE** bump stop to the newly installed bump stop drop brackets.
22. Assemble the rear sway bar end links (**90-8012**) using the supplied bushings (**45359**) and sleeves (**60859**) from hardware pack (**90-6042**). See ILLUSTRATION 1.
23. Install the rear sway bar end link (**90-8012**) into original mounting bracket on the axle using the **OE** hardware.
24. Bolt the remaining end of the sway bar end link to the rear sway bar using the supplied **12mm X 60mm** bolt and hardware. Torque the **12mm** hardware according to the torque chart on page 10.
25. Install your new Pro Comp rear shocks (**MX6151** or **ES9151 w/shaft end up**) using the **OE** hardware. Torque the upper mounting hardware to 20 ft./lbs. and the lower to 35 ft./lbs.
26. On both sides of the vehicle, check the routing of the brake lines and the ABS wire harnesses. There must be no pinching, rubbing, or stretching of either component. Use zip ties to secure these items to the steering components. At full droop, cycle the steering from lock to lock while observing the reaction of these components. Reposition them if needed.
27. Reinstall the rear wheels and lower the vehicle to the ground. Torque the lug nuts according to the wheel manufacturers recommendations.
28. Install the rear track bar to the relocation bracket (**90-5490**) using the supplied adjust-

able cam bolt (90-3718) and hardware from hardware pack (90-6529). Do not torque the cam bolt at this time. See ILLUSTRATION 2.

29. Position your vehicle on a smooth, flat, hard surface (i.e. concrete or asphalt).
30. Rotate the track bar cam bolt until the wheels are centered under the vehicle.
31. Torque track bar cam bolt to 103 ft./lbs.
32. Drive the vehicle forward and backward a few feet to be sure that the axle is adjusted properly and the vehicle is tracking in a straight line.

IMPORTANT!: If the steering wheel is not centered properly it will trigger the anti-lock brake and traction control warning lights.

NOTES:

- ⇒ **On completion of the installation, have the suspension and headlights re-aligned.**
- ⇒ **After 100 miles recheck for proper torque on all newly installed hardware.**
- ⇒ **Recheck all hardware for tightness after off road use.**

Use this only as a guide for hardware without a called out torque specification in the instruction manual.

Bolt Torque and ID						
Decimal System			Metric System			
All Torques in Ft. Lbs. Maximums						
Bolt Size	Grade 5	Grade 8	Bolt Size	Class 9.8	Class 10.9	Class 12.9
5/16	15	20	M6	5	9	12
3/8	30	45	M8	18	23	27
7/16	45	60	M10	32	45	50
1/2	65	90	M12	55	75	90
9/16	95	130	M14	85	120	145
5/8	135	175	M16	130	165	210
3/4	185	280	M18	170	240	290

1/2-13x1.75 HHCS **Grade 5 Grade 8**
(No. of Marks + 2)

D T L X

G = Grade (Bolt Strength)
D = Nominal Diameter (Inches)
T = Thread Count (Threads per Inch)
L = Length (Inches)
X = Description (Hex Head Cap Screw)

M12-1.25x50 HHCS

D T L X

P = Property Class (Bolt Strength)
D = Nominal Diameter (Millimeters)
T = Thread Pitch (Thread Width, mm)
L = Length (Millimeters)
X = Description (Hex Head Cap Screw)

Modifications Page:

8.30.12: Moved (90-3718) cam bolt into hardware pack (90-6529).

10.1.12: Changed kit fitment to include 2013.

Notice to Owner operator, Dealer and Installer:

Vehicles that have been enhanced for off-road performance often have unique handling characteristics due to the higher center of gravity and larger tires. This vehicle may handle, react and stop differently than many passenger cars or unmodified vehicles, both on and off-road. You must drive your vehicle safely! Extreme care should always be taken to prevent vehicle rollover or loss of control, which can result in serious injury or even death. Always avoid sudden sharp turns or abrupt maneuvers and allow more time and distance for braking! Pro Comp reminds you to fasten your seat belts at all times and reduce speed! We will gladly answer any questions concerning the design, function, maintenance and correct use of our products.

Please make sure your Dealer/Installer explains and delivers all warning notices, warranty forms and instruction sheets included with Pro Comp product.

Application listings in this catalog have been carefully fit checked for each model and year denoted. However, Pro Comp reserves the right to update as necessary, without notice, and will not be held responsible for misprints, changes or variations made by vehicle manufacturers. Please call when in question regarding new model year, vehicles not listed by specific body or chassis styles or vehicles not originally distributed in the USA.

Please note that certain mechanical aspects of any suspension lift product may accelerate ordinary wear of original equipment components. Further, installation of certain Pro Comp products may void the vehicle's factory warranty as it pertains to certain covered parts; it is the consumer's responsibility to check with their local dealer for warranty coverage before installation of the lift.