



PRO COMP SUSPENSION

Suspension Systems that Work!

**Part # 56494
94'-2000 Dodge
4WD 1/2" Ton 3" Kit**

This document contains very important information that includes warranty information and instructions for resolving problems you may encounter. Please keep it in the vehicle as a permanent record.

Box 1 of 2-PN 56494-1

Part #	Description	Qty.	Illus.	Page
90-4008	3" Spring Spacer	2	4	5
15-10992	Bumpstop-Red	2	3	5
90-6060	Hardware Pack Containing:			
70-0431251800	7/16" x 1 1/4" USS Gd 8 Hex Bolt	6	4	5
73-04300536	7/16" Split-Lock Washer	6	4	5
13120-1	Add-A-Leaf	2	5	6
95-102	1" Alum. Block	2	5	6
97-380	3/8" SAE Center Bolt	2	5	6
8337-1	3/8" SAE Hex Nut	2	5	6
13-90360	9/16" x 13" U-Bolts	4	5	6
20-65302	Hardware Pack Containing:			
13-10423	9/16" x 18" Hi-Nut	8	5	6
13-30330	9/16" Flat Washer	8	5	6

Box 2 of 2-PN 56494-2

325553	ES3000 Shocks (Front)	2	4	5
325543	ES3000 Shocks (Rear)	2		

Introduction:

- ◆ **This installation requires a professional mechanic!**
- ◆ We recommend that you have access to a factory service manual for your vehicle to assist in the disassembly and reassembly of your vehicle. It contains a wealth of detailed information.
- ◆ Prior to installation, carefully inspect the vehicle's steering and driveline systems paying close attention to the tie rod ends, ball joints, wheel bearing preload, pitman and idler arm. Additionally, check steering-to-frame and suspension-to-frame attaching points for stress cracks. The overall vehicle must be in excellent working condition. Repair or replace all worn or damaged parts!
- ◆ Read the instructions carefully and study the illustrations before attempting installation! You may save yourself a lot of extra work.
- ◆ Check the parts and hardware against the parts list to assure that your kit is complete. Separating parts according to the areas where they will be used and placing the hardware with the brackets before you begin will save installation time.
- ◆ Check the special equipment list and ensure the availability of these tools.
- ◆ Secure and properly block vehicle prior to beginning installation.
- ◆ **ALWAYS** wear safety glasses when using power tools or working under the vehicle!
- ◆ Use caution when cutting is required under the vehicle. The factory undercoating is flammable. Take appropriate precautions. Have a fire extinguisher close at hand.
- ◆ Foot pound torque readings are listed on the Torque Specifications chart at the end of the instructions. These are to be used unless specifically directed otherwise. Apply thread lock retaining compound where specified.
- ◆ ***Please note that while every effort is made to ensure that the installation of your Pro Comp lift kit is a positive experience, variations in construction and assembly in the vehicle manufacturing process will virtually ensure that some parts may seem difficult to install. Additionally, the current trend in manufacturing of vehicles results in a frame that is highly flexible and may shift slightly on disassembly prior to installation. The use of pry bars and tapered punches for alignment is considered normal and usually does not indicate a faulty product. However, if you are uncertain about some aspect of the installation process, please feel free to call our tech support department at the number listed on the cover page. We do not recommend that you modify the Pro Comp parts in any way as this will void any warranty expressed or implied by the Pro Comp Suspension company.***

Please Note:

- Front end and head light realignment is necessary!
- Speedometer and ABS recalibration will be necessary if larger tires (10% more than stock diameter) are installed.
- Tire and wheel selection is crucial in assuring proper fit performance and the safety of your Pro Comp equipped vehicle. For this application a wheel not to exceed 8" in width with a maximum backspacing of 3.5" must be used. Diameter of wheel may be any of the following 2 choices, 15" or 16". Any other diameter, either smaller or larger, will not be endorsed as acceptable by Explorer Pro Comp and will void any and all warranties, written or implied. In addition, a quality tire of radial design, not to exceed 35" tall x 12.5" wide is recommended. **(NOTE: Minor trimming maybe required when using 35" tall tires)**. Exception: 2000 model vehicles will not accept 15" wheels due to brake caliper clearance.

BEFORE YOU BEGIN:

- ⇒ **Read the instructions and study the illustration before attempting installation. Separate parts according to the areas where they will be used. Placing the hardware with the brackets before you begin will save installation time.**
- ⇒ **Check the parts and hardware against the parts list to assure that your kit is complete.**
- ⇒ **Secure and properly block the vehicle prior to beginning installation.**
- ⇒ **Always wear safety glasses when using power tools.**

INSTRUCTIONS:

1) Block the rear wheels of the vehicle in front and behind the tires. Raise the front of the vehicle with a floor jack and support the

frame with jack stands. Remove the front tires.

- 2) Unbolt both brake line brackets from the frame to allow for free movement of the suspension components. Next place an index mark on the bottom of the coil spring and lower spring pocket. The coil spring and lower spring mount can then be installed in the correct position. See ILLUSTRATION 1.
- 3) Locate the top shock mount in the engine compartment. Remove the nut, retainer and grommet from the shock.
- 4) Remove the three nuts from the upper shock bracket, as shown in ILLUSTRATION 2. Remove the bracket and set aside.
- 5) Unbolt the shock absorber from the lower mount bracket on the axle. Remove the shock through the engine compartment. Remove sway bar links and rotate sway bar down and away.
- 6) Carefully lower the floor jack until coil springs are free from the upper spring

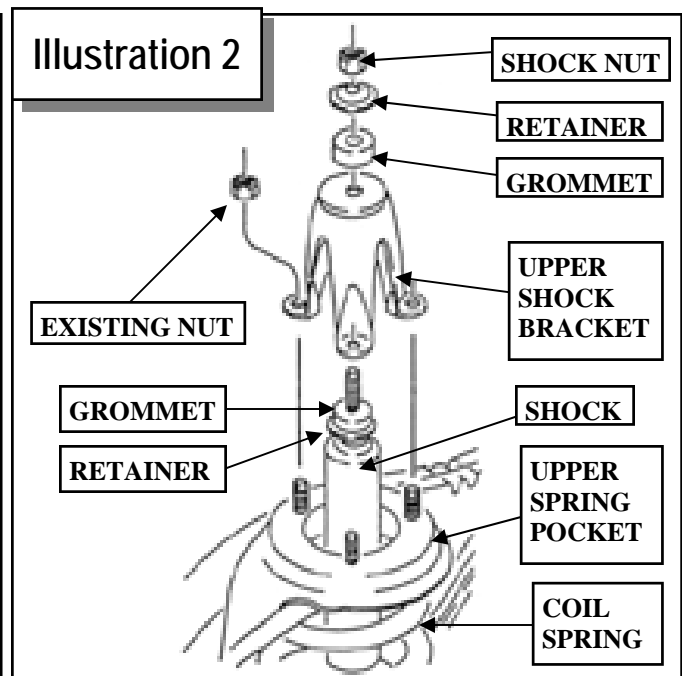
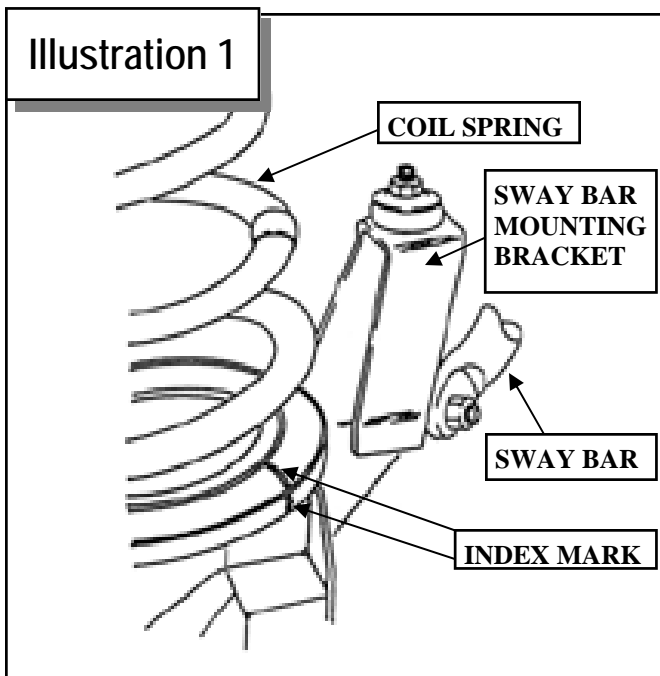

pocket. Remove the coil springs.

7) Remove and set aside the upper rubber isolation pad and the stud ring from the spring pocket. **(NOTE: You will not be reusing the stud ring in the installation).**

8) Locate the front rubber bumpstops, mounted on the frame near the coils. Remove the bumpstop from its pocket using a pair of channel lock pliers. A back and forth action will assist in working it out.

9) Place the new bumpstop, **15-10992**, in existing bumpstop pocket, as shown in ILLUSTRATION 3. By using leverage against the bottom of the bumpstop, force the bumpstop into place (detergent soap may help if the fit is tight).

10) Place the spring spacer, **90-4008**, into the upper spring pocket on the frame, see ILLUSTRATION 4. Align the holes with each other. Then loosely bolt together using **7/16" x 1-1/4"** hex bolt and lock washers. Do not torque down at this time.

11) Insert the rubber isolator pad inside the recess of the spring spacer, see ILLUSTRATION 4.

12) Disconnect track bar at frame mount and inspect for excessive wear. The track bar when attached will not allow the front axle to drop down enough to install spring. Lower axle and install coils. Be sure the coil is properly indexed.

13) Raise the front axle with the floor jack so that it compresses the front coil springs and reattach track bar. Remove the **7/16"** hex bolts from the spring spacer.

14) Insert the shock absorber through the coil spring from the engine compartment.

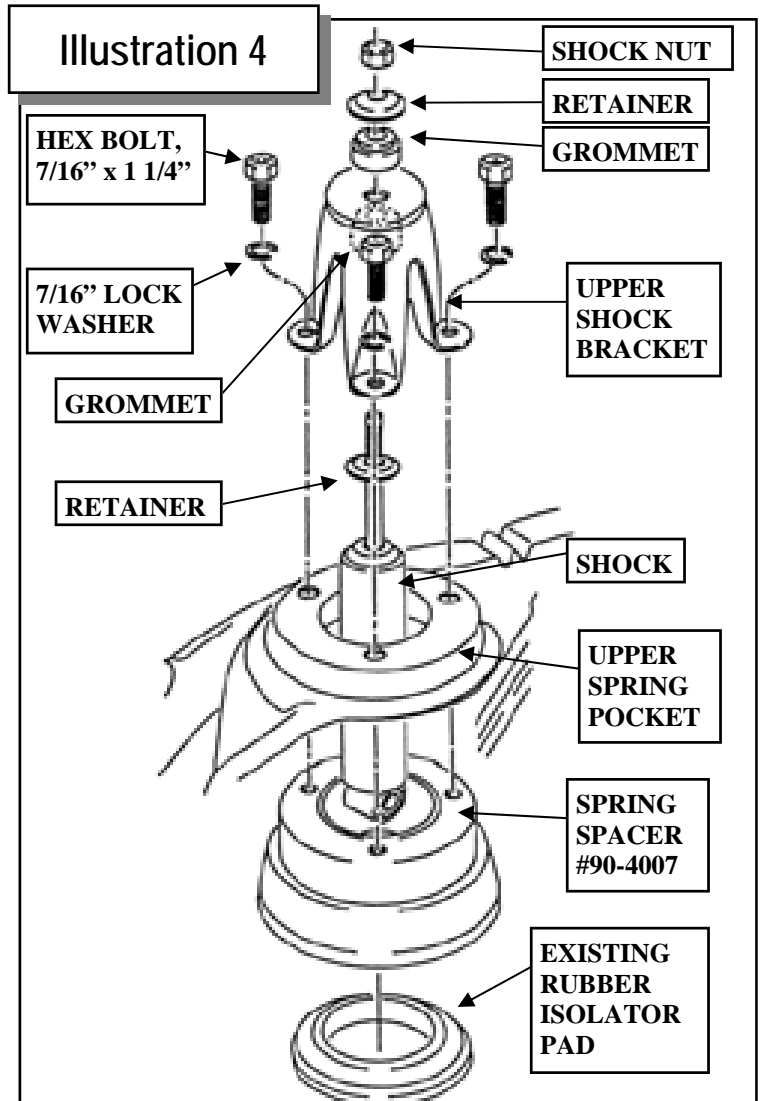
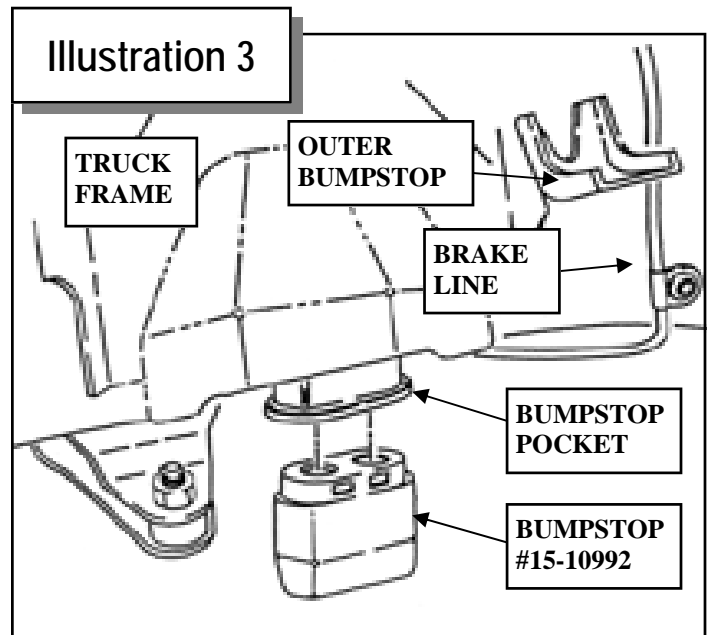

Install the lower shock bolt and torque to 75 ft./lbs.

15) Place the upper shock mount bracket on top of the spring pocket. With the three holes aligned, reinstall the three **7/16" x 1-1/4"** hex bolts and lock washers through the bracket, spring pocket and into the threaded holes in the spring spacer. Torque to 35 ft./lbs.

16) Install the upper shock mount using the grommet and retainer, fastening the shock stud and to the shock bracket with the upper shock nut.

17) Repeat steps 3 through 16 on the other side of the vehicle.

18) Reinstall wheels and lower vehicle.

19) Reattach sway bar links with the vehicle on the ground.

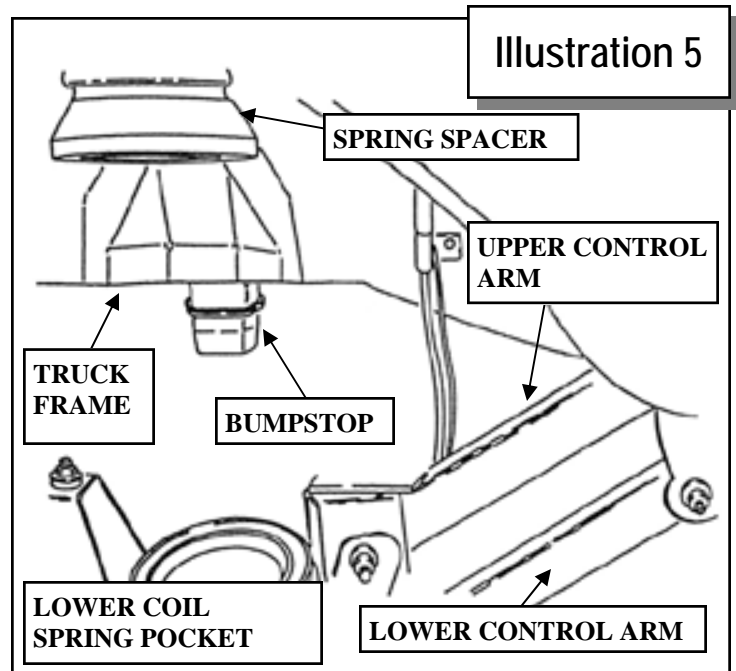

REAR INSTALLATION:

NOTE:

⇒ **To perform the installation properly you must use two large c-clamps or a large vise to contain the elastic potential energy stored in a leaf spring when the center bolt is removed.**

⇒ **If your vehicle is equipped with a thick load leaf at the bottom of the spring pack, place the add-a-leaf between it and the spring pack. Do not install your add-a-leaf below the helper spring.**

1) Raise the rear of the vehicle, support the frame with jack stands and remove the rear wheels.

2) Using the floor jack, raise the rear axle enough to relieve tension on the rear springs.

3) Remove the shock absorbers.

4) Making sure the axle is well supported, remove the axle u-bolts and hardware.

5) Use the c-clamps to hold the spring assembly securely together.

6) Using vise-grips to hold the head of the center bolt, loosen and remove it. If the bolt has rusted, a hammer and drift punch may be used to drive it out. Carefully remove c-clamps.

7) Apply small amount of grease on the end of the add-a-leaf, #13120-1, and hold it centered under the spring pack (concave side up).

8) Install the 3/8" x 4 1/2" center bolt, Load Leaf (if equipped), add-a-leaf and

spring pack. Finger tighten the 3/8" nut.

NOTE: DO NOT USE THE CENTER BOLT TO DRAW THE LEAVES TOGETHER. FAILURE OF ANY COMPONENT CAN CAUSE A EXPLOSIVE DISASSEMBLY AND POSSIBLE INJURY.

9) Make sure that the Load Leaf (if equipped), add-a-leaf and spring pack are centered and aligned. Place one c-clamp on either side of the Center Bolt incrementally. Tighten each c-clamp.

10) Tighten the 3/8" nut all the way down to the center bolt and then torque the hi-nut to 30-35 ft./lbs.

11) Remove c-clamp.

12) Position spring on factory block so that the center bolt head is inserted into the locating hole. Install alum. block 95-102 between factory block and axle tube.

13) Install the u-bolts (2) per side, over the spring pack, blocks and axle tube. Reinstall the anchor plate and fasten the assembly together with the 9/16" hardware provided. Cross torque to 100 ft./lbs.

14) Install shock absorbers and reinstall wheels.

15) Lower the vehicle.

NOTE:

⇒ **Have your vehicle aligned to factory specifications.**

⇒ **Check the torque on all fasteners after the first 100 miles. Periodically inspect the components for tightness. Also check for any damage, especially after off road use.**

Illustration 6

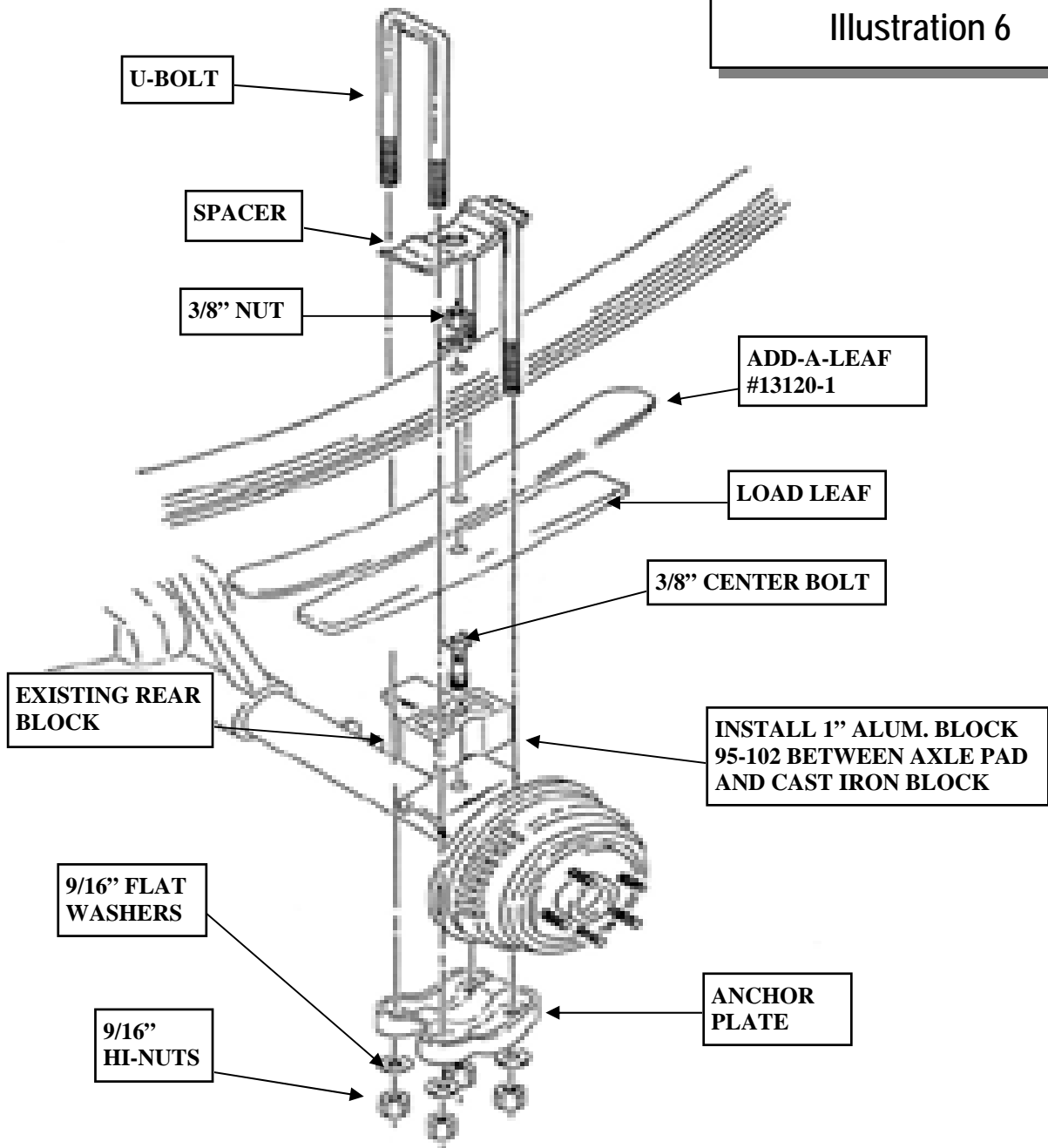

Notice to Owner operator, Dealer and Installer:

Vehicles that have been enhanced for off-road performance often have unique handling characteristics due to the higher center of gravity and larger tires. This vehicle may handle, react and stop differently than many passenger cars or unmodified vehicles, both on and off-road. You must drive your vehicle safely! Extreme care should always be taken to prevent vehicle rollover or loss of control, which can result in serious injury or even death. Always avoid sudden sharp turns or abrupt maneuvers and allow more time and distance for braking! Pro Comp reminds you to fasten your seat belts at all times and reduce speed! We will gladly answer any questions concerning the design, function, maintenance and correct use of our products.

Please make sure your Dealer/Installer explains and delivers all warning notices, warranty forms and instruction sheets included with Pro Comp product.

Application listings in this catalog have been carefully fit checked for each model and year denoted. However, Pro Comp reserves the right to update as necessary, without notice, and will not be held responsible for misprints, changes or variations made by vehicle manufacturers. Please call when in question regarding new model year, vehicles not listed by specific body or chassis styles or vehicles not originally distributed in the USA.

Please note that certain mechanical aspects of any suspension lift product may accelerate ordinary wear of original equipment components. Further, installation of certain Pro Comp products may void the vehicle's factory warranty as it pertains to certain covered parts; it is the consumer's responsibility to check with their local dealer for warranty coverage before installation of the lift.

Warranty and Return policy:

Pro Comp warrants its full line of products to be free from defects in workmanship and materials. Pro Comp's obligation under this warranty is limited to repair or replacement, at Pro Comp's option, of the defective product. Any and all costs of removal, installation, freight or incidental or consequential damages are expressly excluded from this warranty. Pro Comp is not responsible for damages and / or warranty of other vehicle parts related or non-related to the installation of Pro Comp product. A consumer who makes the decision to modify his vehicle with aftermarket components of any kind will assume all risk and responsibility for potential damages incurred as a result of their chosen modifications. Warranty coverage does not include consumer opinions regarding ride comfort, fitment and design. Warranty claims can be made directly with Pro Comp or at any factory authorized Pro Comp dealer.

IMPORTANT! To validate the warranty on this purchase please be sure to mail in the warranty card.

Claims not covered under warranty-

- Parts subject to normal wear, this includes bushings, bump stops, ball joints, tie rod ends and heim joints
 - Discontinued products at Pro Comp's discretion
- Bent or dented product
- Finish after 90 days
- Leaf or coil springs used without proper bump stops
- Light bulbs
- Products with evident damage caused by abrasion or contact with other items
- Damage caused as a result of not following recommendations or requirements called out in the installation manuals
- Products used in applications other than listed in Pro Comp's catalog
- Components or accessories used in conjunction with other manufacturer's systems
- Tire & Wheel Warranty as per Pro Competition Tire Company policy
- Warranty claims without "Proof of Purchase"
- Pro Comp Pro Runner coil over shocks are considered a serviceable shock with a one-year warranty against leakage only. Rebuild service and replacement parts will be available and sold separately by Pro Comp. Contact Pro Comp for specific service charges.
- Pro Comp accepts no responsibility for any altered product, improper installation, lack of or improper maintenance, or improper use of our products.