



PRO COMP SUSPENSION

Suspension Systems that Work!

PLEASE NOTE: This kit is designed to be used in conjunction with Pro Comp Suspension lift kits 57096/57096MX & 57396/57396MX . While this kit may work with other suspension kits, we cannot guarantee fit or performance unless used with genuine Pro Comp Suspension equipment!

**P/N 72083
2005-2009 TACOMA
REAR TRACTION BAR KIT**

This document contains very important information that includes warranty information and instructions for resolving problems you may encounter. Please keep it in the vehicle as a permanent record.

PART LIST

Part #	Description	Qty.	Ill.	Page
90-3429	TRACTION BAR MOUNT FRONT- Drvr	1	3,4,5	5
90-3433	TRACTION BAR MOUNT FRONT- Pass	1	-	-
90-1621	TRACTION BAR MOUNT- Rear	2	2	4
90-6340	HARDWARE PACK: Front Mount	2	-	-
70-0431001800	7/16" X 1 1/4" GR. 8 BOLT	4	4	5
72-043100816	7/16" STOVER NUT	4	4	5
73-0400830	7/16" SAE FLAT WASHER	8	4	5
90-6163	HARDWARE PACK: Bushing	1	-	-
90-2192	SLEEVE 7/8" X 9/16"	2	1	3
90-2193	SLEEVE 7/8" X 9/16"	2	1	3
15-10953	BUSHING	8	1	3
90-6162	HARDWARE PACK: Mounts	1	-	-
70-0625501800	9/16" X 5 1/2" GR. 8 BOLT	2	2	4
70-062450180	9/16" X 4 1/2" GR. 8 BOLT	2	5	5
73-06200032	9/16" USS GR. 8 FLAT WASHER	8	2,5	4,5
72-062100816	9/16" GR. 8 STOVER NUT	4	2,5	4,5

Additional Parts Needed: (Sold Separately)

72500	TRACTION BARS:	-	-	-
90-2435	LATERAL TRACK BAR- Drvr	1	1,5	3,5
90-2437	LATERAL TRACK BAR- Pass	1	2	4

IMPORTANT:

- ◆ This installation requires a professional mechanic!
- ◆ Prior to installation, carefully inspect the vehicle's steering and driveline systems paying close attention to the tie rod ends, ball joints, wheel bearing preload, pitman and idler arm. Additionally, check steering-to-frame and suspension-to-frame attaching points for stress cracks. The overall vehicle must be in excellent working condition. Repair or replace all worn or damaged parts!
- ◆ Read the instructions carefully and study the illustrations before attempting installation! You may save yourself a lot of extra work.
- ◆ Check the parts and hardware against the parts list to assure that your kit is complete. Separating parts according to the areas where they will be used and placing the hardware with the brackets before you begin will save installation time.
- ◆ Check the special equipment list and ensure the availability of these tools.
- ◆ Secure and properly block the vehicle prior to beginning installation.
- ◆ **ALWAYS** wear safety glasses when using power tools or working under the vehicle!
- ◆ Use caution when cutting is required under the vehicle. The factory undercoating is flammable. Take appropriate precautions. Have a fire extinguisher close at hand.
- ◆ Foot pound torque readings are listed on the Torque Specifications chart at the end of the instructions. These are to be used unless specifically directed otherwise. Apply Loctite retaining compound where specified.

INSTALLATION INSTRUCTIONS:

1. Place floor jack under rear axle and raise vehicle. Place jack stands under frame to support vehicle. Set emergency brake and block front wheels, in front and behind tires.
 2. Working on one side of the vehicle at a time, raise the rear tire off the ground, place a jack stand on the flat part of the frame ahead of the rear wheels and remove the wheel.
 3. Support the axle with your floor jack and remove the U-bolts from the axle.
 4. Carefully lower the axle away from the spring pack until there is sufficient clearance to insert the track bar rear mount (90-1621) between the spacer block and the axle mount pad as shown in ILLUSTRATION 2. Do not overextend brake lines or axle vent hose. Both may need rerouting or replacement!
 5. Raise the axle back up into position. Make sure to carefully line up the
- locating bolts and dowels to insure proper alignment. Reinstall the U-bolts, nuts, and washers and torque to 100 ft. lbs. See ILLUSTRATION 2.
6. Install the urethane bushings (15-10953) and sleeves (90-2192 front and 90-2193 rear) into your traction bars (*Bars sold separately*) using ILLUSTRATION 1 for reference.
 7. Using the 1/2" X 5 1/2" bolts install lateral traction bars (90-2437 Pass and 90-2435 Drvr) into the rear mounts. See ILLUSTRATION 2.
NOTE: On the passenger side, the head of the bolt must be on the outside of the vehicle.
 8. Install the front mounts (PN 90-3429 drvr and 90-3433 pass) to the traction bars with the 9/16" X 4 1/2" bolts provided. Leave loose for the moment. See ILLUSTRATION 5.
 9. Repeat on the remaining side of the vehicle.

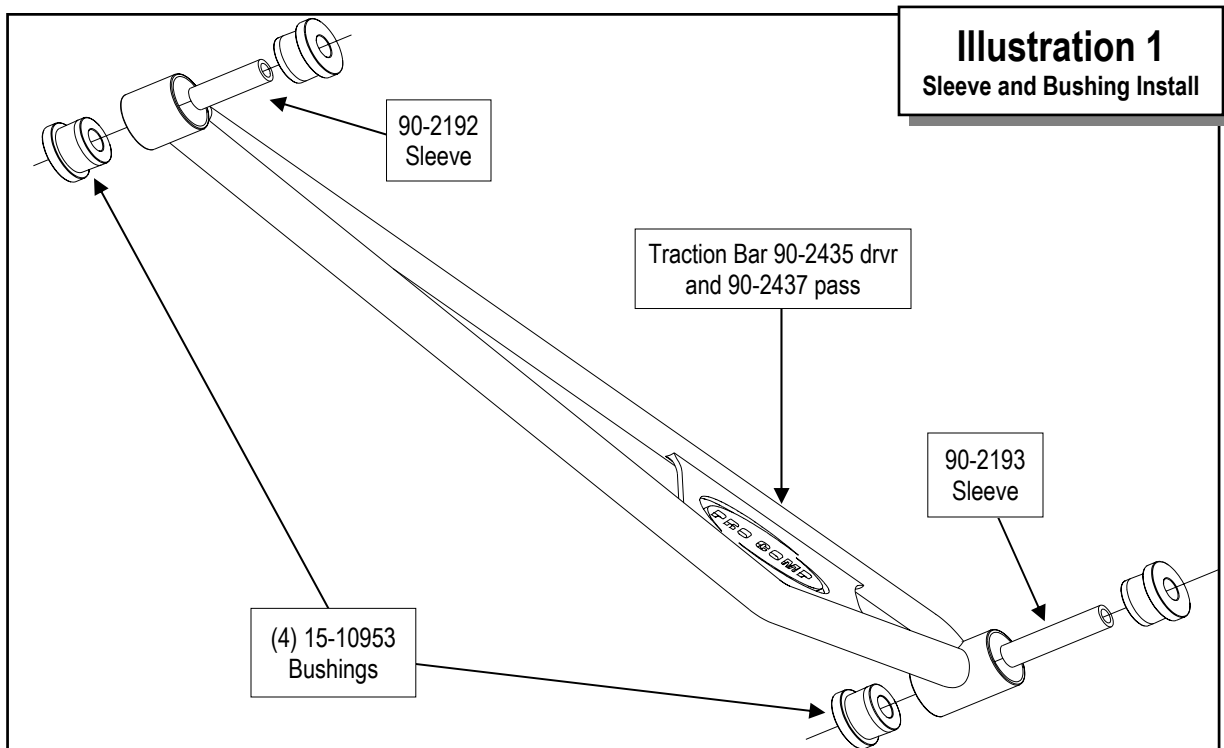

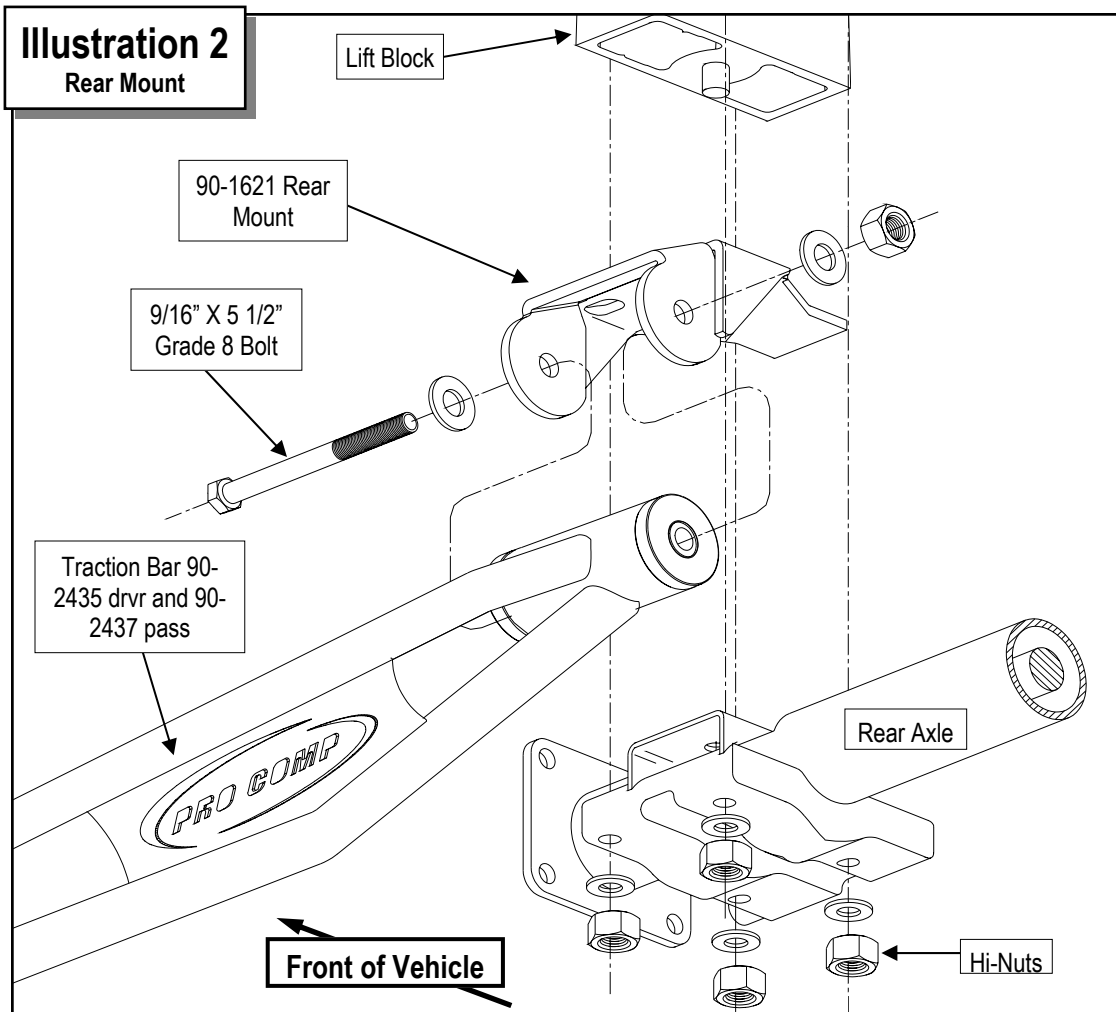

10. Install the tire back on the vehicle and lower the vehicle to the ground.

NOTE: It is VERY important that the next step is done with the truck on the ground, and the suspension is at normal ride height.

11. Raise the track bar up until the front mount (90-3429 drv'r and 90-3433 pass) is in full contact with the frame. Mark the location of the holes in the front mount on the frame (outer and lower) and lower the traction bar. Center punch the locations of the mount holes and drill the (4) holes out with a 29/64" drill bit. See ILLUSTRATION 3.

NOTE: The cut out in the side plate of the front mounts will fit around the rivet head on the frame rail without modification.

12. Remove the front mount from the traction bar. Bolt the front mount to the frame using the (4) supplied 7/16" X 1 1/4" bolts and hardware. See ILLUSTRATION 4.
13. Reinstall the front mounts (PN 90-3429 drv'r and 90-3433 pass) to the traction bars with the previously removed 9/16" X 4 1/2". See ILLUSTRATION 5.
14. Repeat steps 11 and 13 on the remaining side of the vehicle to finish the installation.

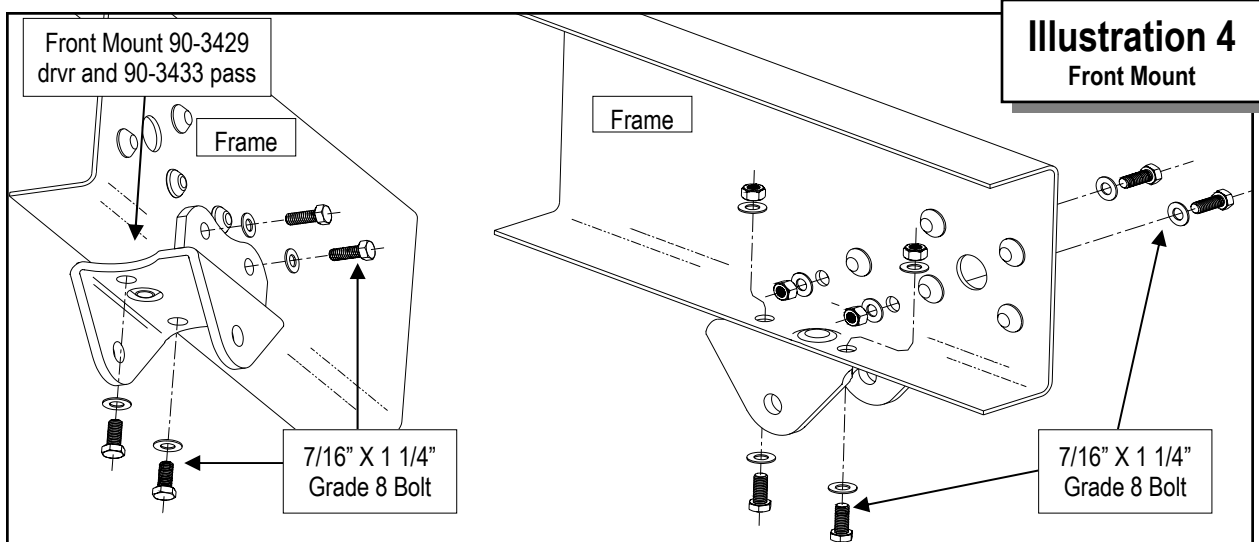
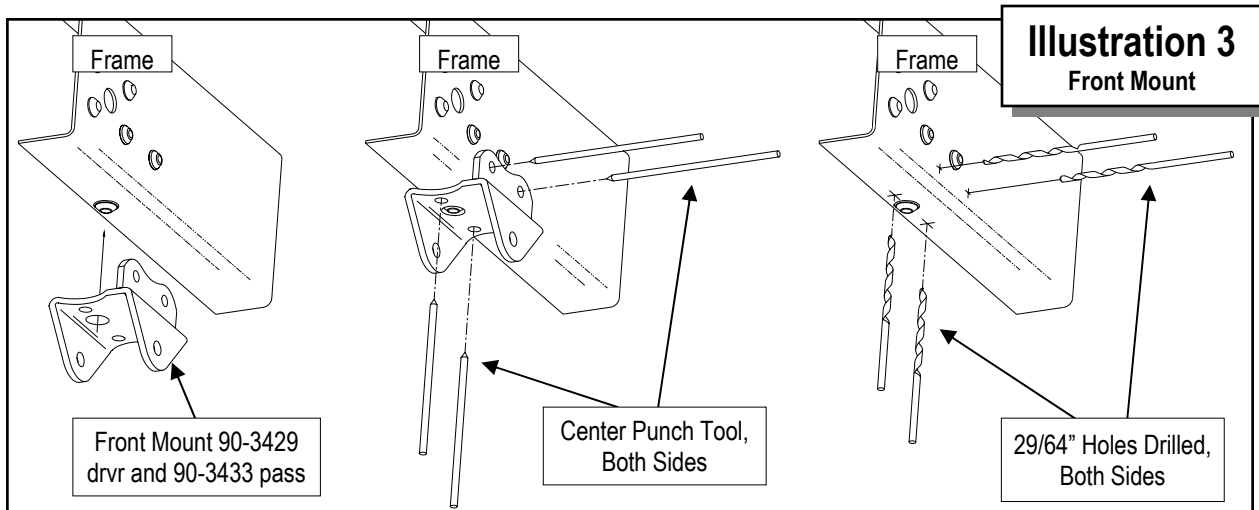

15. Torque all fasteners according to the specifications below.

NOTES:

- ⇒ After 100 miles recheck for proper torque on all newly installed hardware.
- ⇒ Recheck all hardware for tightness after off road use.

Torque Specifications: Grade 8 hardware only	
7/16"	Bolts.....35 ft./lbs.
9/16"	Bolts.....105 ft./lbs

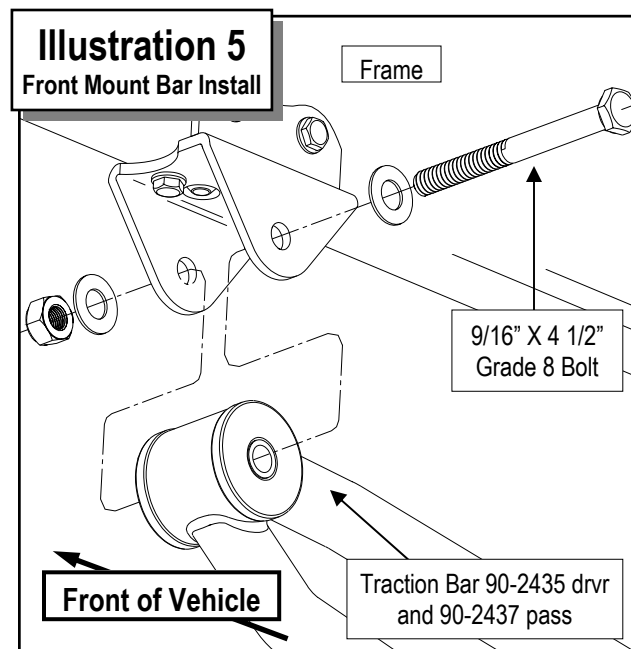

Notice to Owner operator, Dealer and Installer:

Vehicles that have been enhanced for off-road performance often have unique handling characteristics due to the higher center of gravity and larger tires. This vehicle may handle, react and stop differently than many passenger cars or unmodified vehicles, both on and off-road. You must drive your vehicle safely! Extreme care should always be taken to prevent vehicle rollover or loss of control, which can result in serious injury or even death. Always avoid sudden sharp turns or abrupt maneuvers and allow more time and distance for braking! Pro Comp reminds you to fasten your seat belts at all times and reduce speed! We will gladly answer any questions concerning the design, function, maintenance and correct use of our products.

Please make sure your Dealer/Installer explains and delivers all warning notices, warranty forms and instruction sheets included with Pro Comp product.

Application listings in this catalog have been carefully fit checked for each model and year denoted. However, Pro Comp reserves the right to update as necessary, without notice, and will not be held responsible for misprints, changes or variations made by vehicle manufacturers. Please call when in question regarding new model year, vehicles not listed by specific body or chassis styles or vehicles not originally distributed in the USA.

Please note that certain mechanical aspects of any suspension lift product may accelerate ordinary wear of original equipment components. Further, installation of certain Pro Comp products may void the vehicle's factory warranty as it pertains to certain covered parts; it is the consumer's responsibility to check with their local dealer for warranty coverage before installation of the lift.