



---

# INSTALLATION INSTRUCTIONS

PRO COMP SUSPENSION

Part # 532

Camber/Caster adjustable bushing  
'83-'94 4X4 Ford fullsize trucks

1. Remove the upper ball joint cotter pin and nut.
2. To help prevent a tight steering condition and aid in the seating of the New bushing, remove the lower ball joint cotter pin and loosen the nut, but do not remove.
3. Strike the inside of the spindle near the upper and lower ball joints to break the spindle loose from the ball joint studs.
4. Remove the old bushing using a puller or similar tool.
5. Install a 0° bushing and tighten the lower ball joint stud to 40 ft. lbs. Take new readings then determine camber/caster changes needed.
6. Find camber change needed at the top of the chart.
7. Find caster change needed. For driver side use the left side of chart, for passenger side use the right side.
8. Follow the desired measurements to their intersection. In this box you will find two letters. The upper letter is the inner piece adjustment. The lower letter is for the installation reference point.
9. Adjust the inner piece so that the top letter(s) found on chart is centered with slot of the outer piece.
10. Remove 0° bushing.
11. Install the bushing so that the lower letter found on the chart is lined up with the dog or flat located closest to the wheel.
12. Install the upper ball joint stud nut and torque to 85-95 ft lbs.
13. Finish torquing the lower ball joint stud nut to 95-110 ft lbs.
14. Set toe and recheck alignment.

Example Setting Only!!!

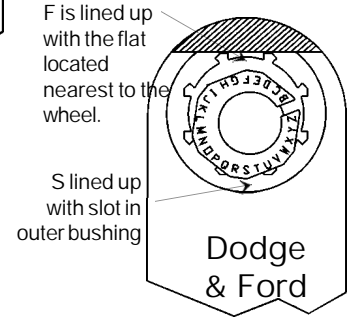
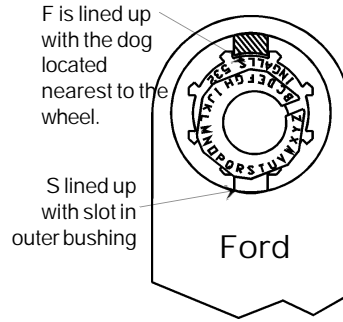

Why use a 0° bushing: Some Ford trucks come from the factory with an offset bushing already installed. Not all of these bushings are clearly marked. Using the 0° bushing eliminates math errors when calculating the proper adjustment needed.

		-NEGATIVE-												CAMBER												+POSITIVE+													
		2 3/4°	2 1/2°	2 1/4°	2°	1 3/4°	1 1/2°	1 1/4°	1°	3/4°	1/2°	1/4°	0°	1/4°	1/2°	3/4°	1°	1 1/4°	1 1/2°	1 3/4°	2°	2 1/4°	2 1/2°	2 3/4°															
D R I V E R  S I D E	+	2 3/4°											N G H												2 3/4°	P A S S E N G E R  C A S T E R  S I D E	-	2 3/4°											
	+	2 1/2°								L E-F	L-M F	M-N G		N-O H	O-P I	P I-J									2 1/2°		-	2 1/2°											
	+	2 1/4°												Q-R E-F	R H	R-S G	S I	J F-G	K G	F-Q G-H	L-H I	M I-J			2 1/4°		-	2 1/4°											
	+	2°																				Q-R K	R K-L	M-N J			2°	-	2°										
	+	1 3/4°																									1 3/4°	-	1 3/4°										
	+	1 1/2°																									1 1/2°	-	1 1/2°										
	+	1 1/4°																									1 1/4°	-	1 1/4°										
	+	1°																									1°	-	1°										
	+	3/4°																									3/4°	-	3/4°										
	+	1/2°																									1/2°	-	1/2°										
	+	1/4°																									1/4°	-	1/4°										
	+	0°																									0°	-	0°										
	+	1/4°																									1/4°	-	1/4°										
	+	1/2°																									1/2°	-	1/2°										
	+	3/4°																									3/4°	-	3/4°										
	+	1°																									1°	-	1°										
+	1 1/4°																								1 1/4°	-	1 1/4°												
+	1 1/2°																								1 1/2°	-	1 1/2°												
+	1 3/4°																								1 3/4°	-	1 3/4°												
+	2°																								2°	-	2°												
+	2 1/4°																								2 1/4°	-	2 1/4°												
+	2 1/2°																								2 1/2°	-	2 1/2°												
+	2 3/4°																								2 3/4°	-	2 3/4°												